

VOLUME E

# **Metropolitan Urban Traffic Control System (MUTC)**

## **Statement of Work**

**Online Tender No. 36/26**

## INDEX

<b>1 OVERVIEW</b>	<b>6</b>
1.1 BACKGROUND	6
1.2 AYALON HIGHWAY COMPANY (AHC0)	6
1.3 METROPOLITAN TRAFFIC CONTROL CENTERS	7
1.4 OVERVIEW OF THE TENDER	7
1.5 DEFINITIONS, ACRONYMS AND ABBREVIATIONS	8
1.6 APPLICABLE DOCUMENTS AND STANDARDS	13
<b>2 MANTAM OPERATIONAL CONCEPT AND MUTC FUNCTIONAL OVERVIEW</b>	<b>16</b>
2.1 MANTAM OPERATIONAL CONCEPT	16
2.2 ROLE OF THE MUTC WITHIN THE MANTAM OPERATIONAL ECOSYSTEM	16
2.3 CENTRAL ROLE OF THE SIM MODULE	17
2.4 SUMMARY	18
<b>3 MUTC OPERATIONAL ENVIRONMENT AND INFRASTRUCTURE OVERVIEW</b>	<b>19</b>
3.1 ON-PREMISES HOSTING AND IT INFRASTRUCTURE	19
3.2 FIELD NETWORK AND OUTSTATION CONNECTIVITY	19
3.3 THE AHC0 TRAFFIC MANAGEMENT ECOSYSTEM	19
3.4 MANAGING SIGNALIZED INTERSECTIONS	20
3.5 PUBLIC TRANSPORTATION PRIORITIZATION	20
3.6 TRAFFIC SITUATION AWARENESS PICTURE	20
<b>4 FUNCTIONAL COMPONENTS REQUIREMENTS</b>	<b>22</b>
4.1 GENERAL	22
4.2 MULTI-SITE SUPPORT	23
4.3 MUTC TRAFFIC TAXONOMY	23
4.4 MUTC FUNCTIONAL MODULES	24
4.5 DATA COLLECTION AND DISSEMINATION LAYER	25
4.6 DATA PROCESSING AND ANALYTICS LAYER	33
4.7 TRAFFIC OPERATION LAYER	44
4.8 SIGNALIZED INTERSECTION MANAGEMENT (SIM) MODULE	55
<b>5 SYSTEM DESCRIPTION</b>	<b>83</b>
5.1 SYSTEM ARCHITECTURE	83
5.2 INFRASTRUCTURE SERVICES	85
5.3 USER WORKSTATIONS REQUIREMENTS	88
5.4 SYSTEM USERS' ADMINISTRATION	88
5.5 CYBER SECURITY	90
5.6 INTERFACES WITH AHC0 INFRASTRUCTURE SERVICES	95
5.7 MUTC INFRASTRUCTURE RESOURCES	96
5.8 MULTI-SITE SUPPORT	97
5.9 GFE DESCRIPTION	97
<b>6 SYSTEM QUALITY AND PERFORMANCE REQUIREMENTS</b>	<b>99</b>

6.1	GENERAL	.....	99
6.2	SYSTEM CUSTOMIZATION AND CONFIGURATION	.....	99
6.3	OPEN ARCHITECTURE	.....	100
6.4	SCALABILITY	.....	101
6.5	CLIENTS	.....	101
6.6	BACKUP AND RECOVERY	.....	101
6.7	CONFIGURATION MANAGEMENT (CM)	.....	101
6.8	FAILURE CONTINGENCIES AND DRP	.....	101
6.9	MAINTAINABILITY	.....	102
6.10	SYSTEM PERFORMANCE	.....	103
6.11	RELIABILITY AND AVAILABILITY	.....	104
<b>7</b>	<b>SUPPLYING AND INSTALLING FIELD DEVICES FOR ADAPTIVE SIGNALIZED INTERSECTION</b>	.....	<b>106</b>
7.1	GENERAL	.....	106
7.2	SUPPLIER RESPONSIBILITIES	.....	107
7.3	COMMUNICATION INFRASTRUCTURE BETWEEN ADAPTIVE FIELD EQUIPMENT AND THE MUTC	.....	108
7.4	GENERAL REQUIREMENTS FOR ADAPTIVE FIELD EQUIPMENT	.....	108
7.5	OBTAINING APPROVAL OF THE INSTALLATION AND OPERATION OF ADAPTIVE FIELD EQUIPMENT	.....	109
7.6	WORK STAGES	.....	110
7.7	WORK SUPERVISION	.....	116
7.8	WORKPLACE SAFETY	.....	117
7.9	PRODUCT WARRANTY SERVICES AFTER INSTALLATION	.....	118
<b>8</b>	<b>BLOCK 2 COMPONENTS</b>	.....	<b>119</b>
8.1	DSS EXTENSIONS FOR INTEGRATIVE RESPONSE PLANS	.....	119
8.2	PLAYBACK	.....	119
8.3	TRAFFIC EVENTS MODULE	.....	120
8.4	INTEGRATED TRAFFIC POLICIES MODULE	.....	121
8.5	TRAFFIC EVENTS SLA CALCULATIONS	.....	122
8.6	AHCO RANGERS' MANAGEMENT MODULE	.....	122
8.7	SYSTEM ARCHITECTURE – HYBRID CONFIGURATION	.....	123
8.8	DATA INTEGRITY	.....	127
8.9	INTERFACE WITH A CELLULAR ROUTER	.....	127
8.10	MIGRATING ACTIVE TRAFFIC INCIDENTS FROM THE LEGACY SYSTEM	.....	127
<b>9</b>	<b>ADDITIONAL WORKLOADS</b>	.....	<b>129</b>
9.1	OVERVIEW	.....	129
9.2	WORKLOADS DESCRIPTION	.....	129
<b>10</b>	<b>MIGRATION FROM THE LEGACY SYSTEM TO THE MUTC</b>	.....	<b>147</b>
10.1	GENERAL	.....	147
10.2	CONNECTING TO SIGNALIZED INTERSECTION	.....	147
10.3	WAZE LINKS	.....	148
10.4	AUTOMATED DATA MIGRATION	.....	148
<b>11</b>	<b>PROJECT MANAGEMENT</b>	.....	<b>149</b>
11.1	GENERAL	.....	149
11.2	DEVELOPMENT METHODOLOGY	.....	152

11.3	PROJECT MANAGEMENT PLAN	.....	156
11.4	REQUIREMENTS MANAGEMENT AND TRACEABILITY	.....	157
11.5	DESIGN STAGES AND REVIEWS	.....	157
11.6	SRR - SYSTEM REQUIREMENTS REVIEW	.....	159
11.7	SDR – SYSTEM DESIGN REVIEW	.....	159
11.8	PDR - PRELIMINARY DESIGN REVIEW.	.....	160
11.9	CDR - CRITICAL DESIGN REVIEW.	.....	161
11.10	SYSTEM INSTALLATION READINESS REVIEW	.....	161
11.11	DELIVERABLES & SCHEDULE	.....	162
11.12	DELIVERABLES DOCUMENTS	.....	162
<b>12 INSTALLATION, TESTING AND SYSTEM HANDOVER</b>			<b>..... 165</b>
12.1	GENERAL	.....	165
12.2	DETAILED TESTS REQUIREMENTS:	.....	166
12.3	FACTORY ACCEPTANCE TEST (FAT)	.....	169
12.4	SYSTEM AND SITE INTEGRATION ACCEPTANCE TEST (SIAT)	.....	169
12.5	SYSTEM ACCEPTANCE TEST (SAT)	.....	170
12.6	INSTALLATION AND DELIVERY	.....	170
12.7	TRIAL RUN	.....	171
12.8	SYSTEM HANDOVER TO AHCO ("HANDOVER")	.....	171
<b>13 TRAINING</b>			<b>..... 173</b>
13.1	GENERAL	.....	173
13.2	OPERATORS' COURSE	.....	174
13.3	ADMINISTRATOR COURSE	.....	174
13.4	MAINTENANCE TECHNICAL COURSE	.....	174
13.5	TRAFFIC ENGINEERS' COURSE	.....	174
<b>14 WARRANTY, SUPPORT &amp; MAINTENANCE</b>			<b>..... 176</b>
14.1	GENERAL	.....	176
14.2	CONTENTS OF THE MAINTENANCE SERVICES	.....	176
14.3	WARRANTY PERIOD AND MAINTENANCE PERIOD	.....	178
14.4	GENERAL INSTRUCTIONS REGARDING THE PROVISION OF MAINTENANCE SERVICES	.....	179
14.5	LICENSES AND RIGHTS OF USE	.....	180
14.6	MAINTENANCE SERVICES PLAN	.....	180
14.7	ADAPTIVE MAINTENANCE – MUTC UPDATES	.....	181
14.8	PREVENTIVE MAINTENANCE	.....	182
14.9	CONTINUOUS MANAGEMENT AND MONITORING OF THE MUTC CLOUD'S INFRASTRUCTURE, SERVICES AND TOOLS	.....	186
14.10	PERFORMANCE-BASED SLA FOR ADAPTIVE INTERSECTION MANAGEMENT	.....	187
14.11	EXTENDED WARRANTY, KNOWLEDGE TRANSFER, AND CALIBRATION OF ADAPTIVE INTERSECTIONS	.....	187
14.12	BACKUP AND RECOVERY	.....	188
14.13	MUTC COMPONENTS' MAINTENANCE RESPONSIBILITY	.....	188
14.14	QUALITY ASSURANCE	.....	189
14.15	ONGOING TRAINING SESSIONS FOR MUTC USERS	.....	190
14.16	FUNCTIONAL CONTINUITY AND RECOVERY FROM EXTREME SITUATIONS	.....	190
14.17	MAINTENANCE SERVICES IN EMERGENCY SITUATIONS	.....	190
14.18	MAINTENANCE SUPPORT CENTER	.....	191

14.19	CORRECTIVE MAINTENANCE	.....	193
14.20	REPORTS AND DOCUMENTATION	.....	198
14.21	PROCEDURE UPON TERMINATION OF THE PERIOD OF ENGAGEMENT	.....	199
14.22	PERIODICAL REPORTS	.....	200
14.23	SPARE PARTS INVENTORY	.....	201

# 1 Overview

## 1.1 Background

The traffic management in the Tel-Aviv metropolitan area is currently fragmented between various authorities, municipalities, and companies. Efficient ITC (Intelligent Traffic Control) implementation requires a central management system to manage and coordinate traffic flow, incident response, and traffic-related events in a synergetic manner. Highway and traffic signal management systems should be in cooperative operation, and available state-of-the-art technologies, including data-based real-time analysis, forecasting based on simulation, and eventually AI tools should augment the integrated ITC ecosystem.

The Israeli Ministry of Transportation (IMOT) has initiated the establishment of metropolitan Traffic Management and Control Centers (MANTAM) which are operated by Ayalon Highways Company Ltd. (AHC Co). The MANTAM is responsible for implementing the IMOT traffic management policy throughout the entire metropolitan area; optimizing the road users' service level – during normal traffic conditions, in periods of high demands, and during Incidents and events; and assist in improving safety and the quality of life in the metropolitan area. The MANTAM hosts representatives from organizations that manage and control traffic routes, operators of major public transportation systems, and other relevant authorities: police, etc.

As part of the traffic control and operation from the MANTAM, AHC Co intends to develop, implement and operate the MUTC – A Metropolitan Urban Traffic Control System, which shall be based on modern and advanced technologies.

The IMOT has defined several Key Performance Indicators (KPIs) for the MANTAM and the MUTC:

- Public transportation efficiency
- General road users' travel time
- Pedestrians' waiting time in main intersections
- Road events time handling
- Accessibility of reliable, efficient and updated traffic information

The MUTC will be designed to support these KPIs as one of the primary tools for the MANTAM operation. The detailed MUTC required capabilities and performances are specified throughout the following chapters of this SOW.

## 1.2 Ayalon Highway Company (AHC Co)

AHC Co is a government entity, as defined in section 1 of the Government Companies Law, 5735-1975, and is subject to the Mandatory Tenders Law, 5752-1992 by virtue of section 2(a) of the law. It is responsible for the management, planning, and execution of transportation initiatives in accordance with government decisions and its founding documents.

Since its establishment, AHC Co has accumulated extensive engineering and managerial experience in complex and large-scale metropolitan and urban projects, and today it is one of the leading companies in planning and executing infrastructure and transportation projects in the State of Israel.

In June 2016, AHC Co became a government company wholly owned by the State of Israel. As a result, its areas of activity have been expanded within the framework of the Socio-Economic Cabinet decision of March 9, 2017 (Decision No. Hk/ 62 1.2.4). By the above decision, the Company is designated to carry out government tasks through the IMOT and engages, inter alia, in the planning, promotion, management, and execution of urban and metropolitan transportation projects throughout the country, as well as in the management, initiation and development of innovation transportation projects, and in adapting the infrastructures to technological progress in vehicles and road facilities.

AHC Co was appointed to plan and manage the traffic in the Tel-Aviv metropolitan area and the Haifa metropolitan area by deploying and operating traffic management and control systems to manage urban, and interurban roads and highways in these metropolitan areas.

In this Tender, AHC Co seeks, as part of the implementation of the MUTC system, to replace Avivim, the current urban traffic management and control system, with a new urban traffic management system. The new urban traffic management module will enable the MANTAM operator to have a comprehensive management and control of the traffic throughout urban areas in the metropolitan area as further detailed in this document.

### 1.3 Metropolitan traffic control centers

The MUTC will be designed to provide services to two metropolitan traffic control centers: MANTAM Dan and MANTAM HaMifratz with the potential for future expansion to additional metropolitan areas. Following is a concise summary of these traffic centers:

#### 1.3.1 The traffic control center of the Tel-Aviv Metropolitan area (MANTAM Dan)

Established in 2020, MANTAM Dan is a metropolitan traffic control center located at the Savidor rail station compound in Tel Aviv, Israel. MANTAM Dan is responsible to oversee and manage the traffic all around the Tel-Aviv metropolitan area including:

- Highway traffic control of Road 20 and parts of Road 2.
- Urban traffic management by operating traffic lights in local authorities.
- Managing and deploying traffic patrollers in AHCo's jurisdiction.
- Real-time administration of public transportation in collaboration with public transportation operators and the IMOT.
- Operation of the Light Rail's Red Line.

The vision of MANTAM Dan is: "Systemic management of urban and interurban transportation in the Tel-Aviv metropolitan area, to improve service and give priority to public transportation, by a uniform and agreed policy, while coordinating between the various agencies, based on advanced technologies, improving accessibility, safety, and quality of life in the metropolis."

#### 1.3.2 The traffic control center of the Haifa Metropolitan area (MANTAM HaMifratz)

MANTAM HaMifratz is responsible for managing the traffic flow around the Haifa Metropolitan area. The control center is located at the Haifa Bay central bus station – Merkazit Hamifratz. Main responsibilities include:

- Urban traffic management by operating traffic lights in local authorities.
- Managing and deploying traffic patrollers in AHCo's jurisdiction.
- Real-time administration of public transportation in collaboration with public transportation operators and the IMOT.
- Coordination of traffic with other road traffic authorities like Carmel Tunnels, Israel Railways, and Haifa Municipality.

The vision of MANTAM HaMifratz is "Systematic management of urban and interurban transportation, in the Haifa metropolitan area, while improving service and giving priority to public transportation, coordination between road authorities, based on advanced technologies, to improve accessibility, safety and quality of life".

#### 1.3.3 MANTAM operational concept and processes

For more details about MANTAM operational concept and processes please read Volume E1 Appendix 11 – MANTAM operational concept and processes

### 1.4 Overview of the Tender

This document describes the MUTC scope and functionality within the framework of the Dan and Haifa metropolitan traffic control ecosystem, its implementation concept, and the requirements and specifications for the MUTC and its components and modules.

Although the MUTC is intended to service the Dan and Haifa metropolitan areas, the implementation should be flexible enough to allow it to serve other metropolitan areas with the inclusion of defining new geographic areas, new relevant interfaces, end clients, and implementation of adequate internal configurations.

The document also specifies the required scope of work including timeframe, deliverables, and required support during the design, implementation, integration and testing, and operation phases. It addresses all the aspects of the project and the tasks and deliverables required for the design, development,

purchase, supply, implementation, integration, testing, maintenance and potential growth, and optional and future upgrades of the MUTC to achieve successful completion of the works connected to this project throughout all of its various stages.

Prior to reviewing the detailed functional, non-functional and technical requirements specified in sections 4 to 6, the Bidder is strongly encouraged to familiarize itself with the division of system capabilities into Blocks and Versions. This structure reflects the intended design, development and deployment of the MUTC system and directly affects the interpretation of scope, dependencies, and implementation expectations across the document. The principles governing the Block and Versions structure are formally defined in Section **Error! Reference source not found.**, and early review of this section is recommended to support a coherent and consistent understanding of the requirements presented in subsequent sections.

## 1.5 Definitions, Acronyms and Abbreviations

#	Acronyms and Definitions	Explanation
1.	Adaptive Signalized Intersection	In an Adaptive Signalized Intersection, the timing of traffic signals changes or adapts in response to real-time traffic demand.
2.	Adaptive Field Equipment	As defined in Section 4.8.19.2. 4.3.2.2
3.	AHCo	Ayalon Highways Company Ltd.
4.	API	Application Programming Interface
5.	ARO	After Receiving Order.
6.	Avivim	Current AHCo Urban traffic management and control system.
7.	AWS	Amazon Web Services (Cloud Services)
8.	BCP Site	Business Continuity Site - A site that allows the company's employees to continue working on the company's systems during emergency situations and in cases where it is not possible to work from the company control centers.
9.	BI	Business intelligence (BI) is a process driven by technology that analyzes business data to provide information that can be actioned so that executives, managers, and operators can make better-informed business decisions. In this Tender it reflects BI platforms such as PowerBI, Qlik, and Tableau.
10.	BL	Business Logics
11.	Block	Block is a major milestone that encompasses the design, development, testing, and deployment of new content of the MUTC.
12.	BoQ	Bill of Quantities
13.	BRT	Bus rapid transit
14.	Business Days	Sunday to Thursday (8:00 AM to 5:00 PM), except for Israeli holidays (including holiday eve) on which businesses in Israel are closed.
15.	C2	Command and Control
16.	C2C	Center to Center interface. The interface between two traffic control systems.
17.	C2F	Center to Field
18.	CCTV	Closed-circuit television (TV)
19.	CDR	Critical Design Review
20.	CDRL	Contract Data Requirements Lists

#	Acronyms and Definitions	Explanation
21.	CM	Configuration Management
22.	COTS	Commercial-off-the-shelf.
23.	CRM	Customer Relationship Management
24.	Daylight Saving Time	Daylight Saving Time is a practice of advancing clocks to make better use of the longer daylight available during summer so that darkness falls at a later clock time. In Israel, the implementation is to set clocks forward by one hour in spring and to set clocks back by one hour to standard time in the autumn.
25.	DB	Database(s)
26.	DC	Domain Controller
27.	Design Reviews	All design review types (SRR, PDR, CDR, TRR)
28.	Detectors Plan	As part of the Traffic Light Timing Plan , the Detectors Plan sets the specific parameters of the detectors.
29.	DMZ	Demilitarized Zone - a perimeter network that protects an organization's internal local-area network (LAN) from untrusted traffic.
30.	DNS	Domain Name System
31.	DR	Disaster Recovery site. It is a data center of the company to back up the Main Site in case of failure.
32.	DRP	Disaster Recovery Plan
33.	DSS	Decision Support System
34.	EDR	Endpoint Detection and Response
35.	ETL	Extract, Transfer, Load. ETL is a data integration process that combines, cleans, and organizes data from multiple sources into a single, consistent data set for storage in a data warehouse, data lake, or other target system.
36.	FALCON	A traffic light control and management system is operated by different kinds of road authorization like the light train operator.
37.	Fast Lane	The "Fast Lane" project includes adding special lanes along Road 2 and Road 20, between Road 57 in the north (Netanya Interchange) and Road 431 in the south (Rishon LeZion interchange). The project also includes a direct connection between the Fast Lane along road twenty (20) and special lanes along Road 5. The Fast Lane is intended for the use of public transport, shuttles, high occupancy vehicles (3+) and toll-paying vehicles.
38.	FAT	Factory acceptance test
39.	FOV	Field of View
40.	Fully Adaptive Management System	A traffic management system that continuously adjusts cycle time, green splits, offset, and phase cycle of the managed Signalized Intersections using real-time traffic flow data from detectors.
41.	GFE	Government Furnished Equipment – All components and services which AHCo provides to the Supplier
42.	GIS	Geographic Information System
43.	GPU	Graphics Processing Unit
44.	Green Wave Offset	The period passed from the beginning of green phase in one Signalized Intersection until the start of the green in coordinated phase at adjacent Signalized Intersection.
45.	GUI	Graphic User Interface
46.	HCM	Highway Capacity Manual

#	Acronyms and Definitions	Explanation
47.	HLA	High-Level Architecture
48.	HTMS	Highway Traffic Management System
49.	HW	Hardware
50.	ICD	Interface Control Document
51.	Ihud Hazala (United Hazala)	Health organization that provides first aid response
52.	Illuminated Guidance Traffic Sign	A traffic guidance sign with illumination capability. The sign displays the allowed traffic Movements relevant to a signal head and is connected to the Signalized Intersection controller.
53.	IMOT	Israeli Ministry of Transportation
54.	HxGN EAM	The AHCo Maintenance System Platform, implemented on the HxGN EAM platform of Hexagon AB, as configured and deployed by GIV Solutions.
55.	Israel Railways	The governmental organization responsible for constructing and operating Israel's national railways and trains
56.	ITC	Intelligent Traffic Control ecosystem
57.	ITCS	Intelligent Traffic Control System
58.	ITS	An Intelligent Transportation System - an advanced application that aims to provide innovative services relating to different modes of transport and traffic management and enable users to be better informed and make safer, more coordinated, and 'smarter' use of transport networks.
59.	JSON	JavaScript Object Notation
60.	KM	Kilometers
61.	KPI	Key performance indicator.
62.	LCS	Lane Control System
63.	LOS	Traffic Level of Service - as defined in Section 4.3.2.3 below.
64.	LPR	License Plate Recognition
65.	LRT	Light Railway Transit
66.	Magen David Adom	Health organization that provides first aid response
67.	Main Site	A data center of the company where the UTC servers and services will be installed.
68.	Malfunction	See definition in Section 14.19.1.3
69.	MANTAM	Metropolitan traffic management control center
70.	Milestone	Milestone video management system
71.	Movement	Movements reflect the road user perspective. Movement is an activity in response to a "go" (green) indication. Typical movements are left, straight and right. Movements can also be divided into classes (car, pedestrians, public transportation, bicycle).
72.	MTBCF	Mean Time Between Critical Failures
73.	MTBF	Mean Time Between Failures

#	Acronyms and Definitions	Explanation
74.	MTTR	Mean Time to Recovery or Repair
75.	MUTC	Metropolitan Urban Traffic Control system
76.	NAC	Network Access Control
77.	NATI	The National Transport Infrastructure Company Ltd.
78.	NIMBUS	AWS Local (IL) Zone services
79.	NIS	New Israeli shekel. Israel currency.
80.	NOC	Network Operating Center
81.	Nofit	A regional light rail system designed to serve northern Israel and to create a fast and efficient transport link between the three main hubs of the northern metropolitan area.
82.	NTA	The Metropolitan Mass Transit System Ltd is in charge of the LRT in the Dan Metropolitan
83.	NTCIP	National Transportation Communications for Intelligent Transportation System Protocol
84.	NTP	Network Time protocol. Network protocol for clock synchronization between computers.
85.	ONVIF	Open Network Video Interface Forum
86.	OT Network	A private secure computer network of AHCo on which all the traffic management systems are running.
87.	Outstation Device	All the computer equipment, communication, electricity, cabinets, and traffic management equipment installed at intersections and on the roads. (cellular routers, cabinets, switches, UPS, etc.)
88.	PDR	Preliminary Design Review
89.	PRTG	PRTG is a Paessler's software for monitoring networks.
90.	PTZ	Pan, Tilt, and Zoom
91.	Push Button	Push Button for pedestrians.
92.	QA	Quality Assurance
93.	QC	Quality Control
94.	Response Plans	As defined in Section 4.3.2.2
95.	REST	Representational state transfer
96.	RPO	Recovery Point Objective is the maximum acceptable amount of data loss after an unplanned data-loss incident, expressed as an amount of time.
97.	RTO	The Recovery Time Objective is the maximum acceptable amount of time for restoring a network or application and regaining access to data after an unplanned disruption.
98.	SAST	Static Application Security Testing
99.	SAT	System Acceptance Test
100.	SDK	Software development kit
101.	SDR	System Design Review
102.	SDRL	Subcontractor Data Requirements List

#	Acronyms and Definitions	Explanation
103.	SIAT	System Integration Acceptance Test
104.	SIDERA	SICE HTC
105.	SIEM	Security Information and Event Management
106.	Signalized Intersection	a road junction where traffic flow is controlled by traffic lights to manage the Movement of vehicles, cyclists, and pedestrians.
107.	SIM	Signalized Intersection Management
108.	SLA	Service-Level Agreement.
109.	SOC	Security Operation Center for monitoring and response to cyber incidents.
110.	SRR	System Requirement Review
111.	SSO	Single Sign On
112.	Supervisor	A representative appointed by AHCo, whose appointment is notified to the Supplier, to oversee and supervise all or part of the scope of work under this contract.
113.	SW	Software
114.	TBD	To Be Defined
115.	Temporary Traffic Arrangement	Traffic management measures implemented during road work to maintain the safety of pedestrians and vehicles and the efficient flow of traffic.
116.	Tender	E-Tender (Online) No. 36/26 For the Supply, Integration, Operation and Maintenance of a MUTC (Metropolitan Urban Traffic Control) System
117.	The Supplier	The Bidder who won the Tender.
118.	TMDD	Traffic Management Data Dictionary
119.	Traffic Incident	Occasional events which do not have a beforehand known date of occurrence such as traffic accidents and Malfunctions in traffic lights.
120.	Traffic Event	Any occurrence affecting, or potentially affecting, traffic conditions, road operations, or traveler information, whether planned or unplanned. An Event includes, among other things, scheduled activities such as roadworks, public events, and planned lane closures, as well as unplanned occurrences such as Traffic Incidents.
121.	Traffic Light Timing Plan	A Traffic Light Timing Plan outlines the sequence and timing of traffic signals at an intersection. It is a collection of parameters and logic designed to allocate the right-of-way at a Signalized Intersection.
122.	Traffic Light Controllers	A field device or subsystem that operates and coordinates the signal indications at a Signalized Intersection, by controlling the timing, sequence, and logic of traffic lights in accordance with configured signal plans, sensor inputs, priority requests, and commands from higher-level traffic management systems.
123.	Traffic Management Device	Equipment used to manage traffic, and which is installed at intersections and roads such as Traffic Light Controllers, variable message signs, etc.
124.	TRR	Test Readiness Review
125.	TSPD	Traffic Situation Picture Display
126.	Unified Format	An XML (XSD) template, defined and distributed by the Ministry of Transport, defines the structure of the traffic signal program based on which, it is possible to export a traffic signal program

#	Acronyms and Definitions	Explanation
127.	URL	Uniform Resource Locator
128.	UTC	Urban traffic management and control system
129.	VCRM	Verification Cross Reference Matrix
130.	Version	Denotes an update within a given Block
131.	VMS	Variable Message Signs
132.	VPS	Variable Prismatic Sign
133.	Waze	Navigation mobile application
134.	WBS	Work Breakdown Structure, a tool to plan and manage complex projects by dividing them into smaller tasks
135.	XML	Extensible Markup Language

*Table 1 - Acronyms and Definitions*

## 1.6 Applicable Documents and Standards

The Supplier shall conform to all the standards and guidelines listed in this section and supplemented by any additional standards and guidelines, that the Supplier uses for the implementation of the project, and are not mentioned in the following list.

### 1.6.1 Standards and guidelines

The Supplier is required to meet and be certified to the latest versions of the following standards and guidelines as specified in the table below (Table 2). The Supplier may propose alternative or parallel standards or guidelines. Such alternatives will be considered acceptable only if they demonstrate full equivalence or superiority to the listed standards, as evaluated by AHCo during the Proposal review stage. AHCo reserves the right to reject the Supplier's proposal if there are doubts regarding the adequacy, equivalence, or compliance of the proposed standards or guidelines. The Supplier must provide convincing evidence that all its associated partners and utilized software components within its proposed solution also meet the prescribed standards and guidelines in the table below. Convincing evidence for compliance shall be provided within the timeframes specified in the table below.

#	Document Name	Document type	Proof of achievement	Latest date for evidence submission
1.	ISO 9001	Organizational certification	Formal certification	Kick-off meeting
2.	ISO 27001	Organizational certification	Formal certification	Kick-off meeting
3.	CMMI	Organizational processes framework	Evidence of execution from previous projects, accompanied by a reference to the particular project and the client's contact information.	Kick-off meeting
4.	OWASP Top 10	Guidance to prevent web application security risks.	Evidence of execution in the MUTC.	Block 1 (version 1) FAT *
5.	CWE\SANS Top 25	Highlights of the most critical software coding errors	Evidence of execution in the MUTC.	Block 1 (version 1) FAT *
6.	SDLC	Framework for software development life cycle	Evidence of execution in the MUTC.	Block 1 (version 1) FAT *
7.	SSDLC	Framework for secured software development life cycle	Evidence of execution in the MUTC.	Block 1 (version 2) FAT *
8.	ISO 27017	Guidelines for information security controls specific to cloud services	Formal certification	Block 1 (version 2) FAT *

*Table 2 - Applicable standards and guidelines*

\* May entitle Supplier to quality score points if presented in its Tender Proposal.

1.6.2 Interface standards

The Bidder shall design all Center-to-Center (C2C) and Center-to-Field (C2F) interfaces in accordance with recognized international standards, primarily NTCIP, TMDD, DATEX II, MQTT and DVI35. Where specific data exchanges are not covered by these standards, or upon AHCo's specific request, interfaces shall be implemented using REST/JSON protocols. Video system interfaces shall comply with ONVIF or WebRTC, while public-transport interfaces shall conform to SIRI-SM and GTFS standards.

The final selection and confirmation of the interface standard for each connection shall be defined and approved during the CDR, based on the specific interfaces to be implemented in the relevant Block.

The following table presents the relevant standards expected to be applied in the project.

#	Document Name	Document type	Proof of achievement	Latest date for evidence submission
1.	TMDD 3.03 or above	Dictionary	Successful SAT	Block 1 (version 1) SAT
2.	NTCIP 2306	C2C protocol	Successful SAT	Block 1 (version 2) SAT
3.	NTCIP 1203	C2F protocol	Successful SAT	Optional requirement.
4.	DATEX II	C2C protocol	Successful SAT	Block 1 (version 1) SAT
5.	SNMP V3	C2F protocol and device monitoring	Successful SAT	Block 1 (version 1) SAT
6.	DVI35	C2F Protocol to manage and control Traffic Light Controllers	Successful SAT	Block 1 (version 1) SAT
7.	Modbus	C2F Protocol to manage and control Traffic Light Controllers	Successful SAT	Block 1 (version 1) SAT
8.	Modular-Extensible Protocol MEP200802	C2F protocol to manage VMS signage	Successful SAT	Optional requirement.
9.	SIRI-SM	Realtime information for public transportation.	Successful SAT	Block 1 (version 2) SAT
10.	GTFS	Common data format for public transportation schedules and associated geographic information.	Successful SAT	Block 1 (version 2) SAT
11.	OCIT-O	C2F protocol to manage Signalized Intersections	Successful SAT	Optional requirement.
12.	ONVIF \ WebRTC	Communication interfaces between devices (such as IP surveillance cameras) and software clients	Successful SAT	Block 1 (version 2) SAT
13.	JSON over REST API	Default format for alternative or unsupported interfaces (C2C/C2F).	Successful SAT	Block 1 (version 1) SAT

*Table 3 - Applicable interface standards*

1.6.3 Recommended standards and guidelines

The subsequent listing comprises supplementary standards and guidelines that, while not mandatory for the Supplier to obtain certification or implement throughout the MUTC development process, may be utilized to assess the organizational quality of the Supplier and acquire additional points during the evaluation of its Proposal.

#	Document Name	Proof of achievement
1.	ISO 27002	Valid and current formal certification issued by an accredited certification body.

2.	SOC2	Demonstrated implementation in prior projects, including project reference details and client contact information for verification.
3.	NIST Cybersecurity Framework	Demonstrated implementation in prior projects, including project reference details and client contact information for verification.
4.	NIST 800-125	Demonstrated implementation in prior projects, including project reference details and client contact information for verification.
5.	NIST 800-218	Demonstrated implementation in prior projects, including project reference details and client contact information for verification.
6.	CSA CMM (CMMC)	Formal certification for the organization's maturity level
7.	ISO 22301	Valid and current formal certification issued by an accredited certification body.
8.	ISO 27005	Valid and current formal certification issued by an accredited certification body.
9.	ISO 27014	Valid and current formal certification issued by an accredited certification body.
10.	ISO 27032	Valid and current formal certification issued by an accredited certification body.
11.	ISO 27034	Valid and current formal certification issued by an accredited certification body.
12.	ISO 27035	Valid and current formal certification issued by an accredited certification body.
13.	ISO 27040	Valid and current formal certification issued by an accredited certification body.
14.	ISO 29119	Valid and current formal certification issued by an accredited certification body.
15.	CERT Secure Coding Standards	Demonstrated implementation in prior projects, including project reference details and client contact information for verification.
16.	GDPR*	Demonstrated implementation in prior projects, including project reference details and client contact information for verification.
17.	ANSI/HFS 500	Demonstrated implementation in prior projects, including project reference details and client contact information for verification.
18.	ISO11064	Valid and current formal certification issued by an accredited certification body.

*Table 4 - Recommended standards and guidelines*

\* Compliance with GDPR is required when handling sensitive private data (as defined in the GDPR). Specific guidelines are outlined in section 5.5.8.

## 2 MANTAM Operational Concept and MUTC Functional Overview

Chapter 2 provides general background and contextual information regarding the MANTAM operational concept and the role of the MUTC within that environment. This chapter is intended for explanatory purposes only and does not define binding contractual, functional, technical, interface, performance, implementation, or other requirements. All binding requirements are set out in Chapter 4 and in the chapters that follow it. In the event of any discrepancy, inconsistency, ambiguity, or contradiction between this chapter and the binding requirements specified from Chapter 4 onward, the latter shall govern and prevail.

### 2.1 MANTAM Operational Concept

The MANTAM operates under the Ayalon Highways Company (AHC) on behalf of the Ministry of Transport (IMOT). Its mission is to ensure optimal, safe, and coordinated traffic flow across the metropolitan road network by integrating urban, interurban, and public-transport operations into a single management framework. The operational concept of the MANTAM is built around four complementary processes that form a continuous control loop:

#### 2.1.1 Traffic Response-Plan Planning

Definition of required Levels of Service (LOS) and the preparation of standard traffic plans for normal conditions, as well as predefined Response Plans for Traffic Event .

#### 2.1.2 Traffic Situation Picture

Continuous collection, fusion, and analysis of traffic data from sensors, Traffic Light Controllers, external systems, municipalities, and public-transport operators to generate a metropolitan-wide situational view. The situation picture is disseminated to all relevant users and systems within the ITC ecosystem.

#### 2.1.3 Traffic Management and Control

Execution of real-time management actions in response to Traffic Events or congestion anomalies. Operators apply pre-defined or adaptive traffic-light plans, coordinate with field forces and emergency services, and manage public-transport prioritization.

#### 2.1.4 Debriefing, Statistics, and Research

Post-event and periodic analyses of operational data to assess performance, detect trends, and improve policy, plans, and LOS definitions. Insights are derived from structured MUTC data and BI analytics.

These processes are executed by dedicated MANTAM units - Traffic Management, Traffic Planning, Maintenance, and IT, supported by coordination with external stakeholders such as IMOT, Police, NTA, NATI, and local municipalities. Together, they create a unified operational framework in which the MUTC system plays a central technological role.

### 2.2 Role of the MUTC within the MANTAM Operational ecosystem

The Metropolitan Urban Traffic Control System (MUTC) forms a key component of the traffic control ecosystem operated by the Ayalon Highways Company (AHC) under the Ministry of Transport (IMOT).

The ecosystem integrates multiple systems that collectively enable metropolitan-level traffic management, including highway control, urban signal management, public transport prioritization, and Traffic Events response. The MUTC complements other major systems such as the SIDERA Highway Traffic Management System (HTMS), the Falcon Light-Rail control system, and video, BI, and maintenance systems, creating a unified operational and data environment across the metropolitan areas of Dan and HaMifratz.

The MUTC will serve as the central platform for urban traffic operations, ensuring coordinated signal management, data sharing, and Traffic Events handling between urban intersections, highways, and public transport systems. The system shall interface with these elements via Center-to-Field (C2F) and Center-to-Center (C2C) protocols.

The following diagram illustrates the high-level functional interfaces between the MUTC and other traffic control & management systems and additional C2 systems. The diagram encompasses both interfaces that are anticipated to be implemented as part of the Tender and future interfaces that may be implemented as additional workloads.

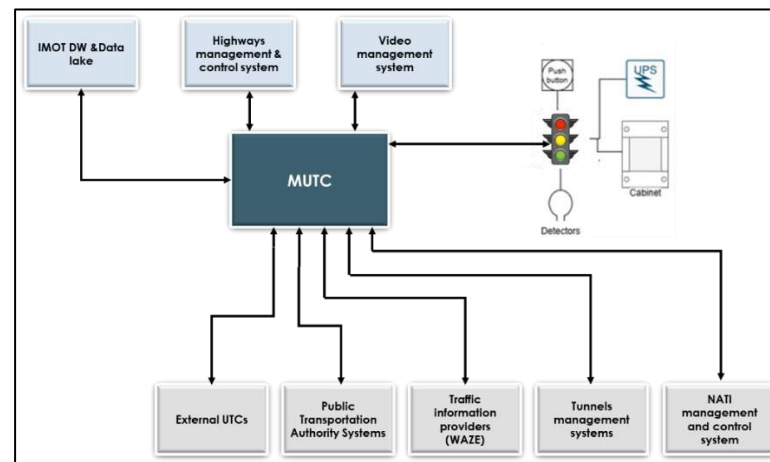

Figure 1 - The MUTC within the overall traffic control ecosystem of the Dan and Haifa metropolitan area

## 2.3 Central Role of the SIM Module

At the core of the MUTC lies the Signalized Intersection Management (SIM) module, which constitutes the operational foundation of urban traffic control. The SIM module manages all communications with Traffic Light Controllers, orchestrates intersection behavior, and provides the operational link between strategic decision-support functions and field execution.

The SIM module's principal roles include:

### 2.3.1 Real-time Control and Monitoring

- Continuous supervision of all connected Traffic Light Controllers, including status, faults, and active traffic-light plans.
- Near real-time visualization of intersection operations, phases, and cycle times.
- Remote download, modification, and activation of traffic plans, with synchronization to predefined weekly schedules or adaptive logic.

### 2.3.2 Adaptive and Coordinated Operation

- Dynamic adjustment of green times and cycle lengths in response to traffic conditions or events.
- Formation and control of coordinated “green-wave” corridors across multiple intersections and municipalities.
- Integration of priority rules for public transportation, emergency vehicles, and special events, using detector data or external requests.

### 2.3.3 Data Acquisition and Analytics Enablement

- Collects raw and processed data from Traffic Light Controllers, detectors, and sensors to feed other MUTC modules.
- Provides structured logs of every operational change, enabling traceability, auditing, and post-event analysis.

By consolidating all intersection-related data and control logic, the SIM module enables real-time situational awareness, coordinated traffic management, and seamless integration with the wider metropolitan traffic ecosystem.

## 2.4 Summary

Through its integration with complementary systems, the MUTC, and particularly its SIM module, will provide the MANTAM centers with a unified operational picture, real-time decision-support tools, and the capability to execute adaptive responses across thousands of intersections.

This interoperability ensures that urban traffic management aligns with strategic objectives for efficiency, safety, and public transport priority throughout the metropolitan network.

### 3 MUTC Operational Environment and Infrastructure overview

This chapter provides a high-level overview of the operational environment and technical environment provided by the Ayalon Highway Company (AHC) in which the MUTC system will be hosted. It outlines some key operational concepts that AHC uses to manage traffic. In addition, this chapter provides an overview of the infrastructure, field connectivity, and the broader ecosystem of on-premises systems with which the MUTC must coexist and interact. This chapter is intended for contextual and explanatory purposes only and does not define specific binding requirements. The detailed and binding requirements applicable to the MUTC are set out in the following chapters of this SOW.

#### 3.1 On-Premises Hosting and IT Infrastructure

The MUTC will be hosted within the AHC's OT Network, a dedicated and secured private computing environment designed for mission-critical traffic operations. The OT Network is not part of the Tender, and it is operated by AHC.

- 3.1.1 Data Center Topology: The environment is distributed across two separate data center sites in an Active-Active topology. This utilizes redundant virtual machine clusters to ensure continuous operational availability and resilience against site-level failures. Each MANTAM/control center is connected to both data centers.
- 3.1.2 Infrastructure Services: The hosting environment provides centralized support services, including:
  - Identity Management: Active Directory for unified user authentication and authorization.
  - Synchronization: NTP services for millisecond-accurate clock alignment across the network.
  - Security & Continuity: Centralized backup, disaster recovery, cybersecurity tools, and monitoring solutions (NOC/SOC).
- 3.1.3 Detailed internal system architecture and software components are described in Chapter 5.

#### 3.2 Field Network and Outstation Connectivity

The MUTC acts as the central control point for a vast network of Outstation Devices, connected via the AHC's OT network infrastructure.

- 3.2.1 Communication Media: Outstation Devices, specifically Traffic Light Controllers, are reached through either a Fiber-based network or a secure Private APN mobile network which is part of the OT network.
- 3.2.2 Communication with Traffic Light Controllers: The MUTC will manage at least four (4) distinct types of Traffic Light Controllers manufactured by global leading companies like Swarco and Siemens. C2F Communication to Traffic Light Controllers is based on few variations of the serial communication protocol called DVI35. DVI35 protocol is based on standard IEC 870-5-2. See section 4.5.2.4 for more details about the types of Traffic Light Controllers and the communication protocols. Unless otherwise specified, AHC's third-party contractors handle the supply and maintenance of Traffic Light Controllers and any components of a Signalized Intersection.

#### 3.3 The AHC Traffic Management Ecosystem

The MUTC is a primary component within a broader integrated environment of traffic management systems. It must maintain interfaces with several on-premises systems to create a unified situational picture:

- 3.3.1 Traffic & Highway Management: Interaction with the SIDERA HTMS for coordinated highway and urban traffic operations.
- 3.3.2 Visual & Spatial Awareness: Integration with the Milestone Video Management System (VMS) for CCTV control and an ESRI-based GIS service for spatial data and road topology.
- 3.3.3 Maintenance and Logistics: Interfacing with the HxGN EAM system to manage asset health, inventory, and automated fault reporting.
- 3.3.4 Future Integration Points: The environment is designed to accommodate future interfaces, including public transportation authority systems (GTFS/SIRI), third-party video analytics (DFS), and future V2X infrastructure blocks.

### **3.4 Managing Signalized Intersections**

Each MANTAM independently manages the Signalized Intersections that are under the MANTAM's responsibility. Each MANTAM manages Signalized Intersections for multiple municipalities as described in Volume E1, Appendix 1 – list of municipalities.

The capabilities of the Signalized Intersection are described in sections 4.5.2.4, 4.7.2.4.1, and 4.8.6. It is required that the MUTC shall monitor the operation of each Signalized Intersection in near-real-time, and check that each Signalized Intersection is working as requested, and shall notify users regarding exceptions, malfunctions, and irregularities.

Some of the Signalized Intersections work in coordination as part of a synchronized Green-Wave or a sub-network of Signalized Intersections. Each Signalized Intersection may change the green wave network or sub-network it belongs to during the time of the day. The MUTC must consider that in some cases, the green wave may cross multiple municipalities.

As of the date of publication of the Tender, all Signalized Intersections work according to a predefined weekly schedule. The schedule specifies the Traffic Timing Plan to be executed for each hour of every day of the week. The operators use the urban traffic control system to define and manage the weekly schedule. When needed, operators temporarily adjust the active Traffic Timing Plan for one or multiple Signalized Intersections to manage unusual congestion.

The current urban traffic management system includes the following tools to help manage the traffic.

- A decision support module that helps users choose the best Traffic Light Timing Plan for specific traffic conditions at a Signalized Intersection.
- Automatically applying a specific Traffic Light Timing Plan to a Signalized Intersection for a set period based on user-defined conditions.

As stated, the new MUTC will add a centralized adaptive traffic management, see sections 4.8.19 and 7 for the detailed requirements.

### **3.5 Public transportation prioritization**

The MUTC shall support, in the ordered Block and any future Block, prioritization strategies for different types of public transportation projects that operate or will be operated in each metropolitan area. In MANTAM HaMifratz there are two (2) public transportation projects, the Metronit project which is a BRT project and Nofit light rail project. In both projects, the MUTC will not be directly involved in the prioritization process, as the Signalized Intersection receives prioritization requests via dedicated priority detectors. In the two projects, the MUTC will monitor the operation of the Signalized Intersection by gathering data from the Signalized Intersections and the priority detectors. In addition, the MUTC will allow users to update Traffic Light Timing Plans priority parameters and download them into the Signalized Intersection. The MUTC will also allow users to manually switch between the active Traffic Light Timing Plans in case of traffic management requirements. The MUTC will provide a DSS tool for selecting the best plan. As the Metronit project and the Nofit light rail project use different sets of Traffic Light Plans parameters, the MUTC will need to support multiple sets of plan parameters.

A future second priority-strategy type shall require the MUTC to send priority requests to Signalized Intersections based on requests received from external systems.

Detailed requirements from the MUTC to support each type of prioritization are described later in sections 4.8.18, 9.2.2.1.

### **3.6 Traffic situation awareness picture**

#### **3.6.1 Congestion Level of Service**

The existing urban traffic management system offers a traffic situation awareness that shows congestion levels in metropolitan areas and provides details about Traffic Events. The system also calculates congestion level anomaly based on historic congestion level data. As for today, AHCo uses Waze data to generate level-of-service information for congestion across the road network surrounding the Signalized Intersections. In Waze, users set up road links to represent each movement at a signalized intersection. Via the Waze API interface, Waze provides information about average travel time for every two (2) minutes for each link.

The existing urban traffic management environment uses Waze link data and the Signalized Intersections green times in each cycle to calculate and support congestion monitoring on the road network surrounding Signalized Intersections. Within this context, congestion level-of-service indications may be derived using a combination of traffic data sources, including Waze data, strategic detectors and other traffic data sources. The operational concept also includes the identification of unusual congestion patterns based on historical traffic data, enabling operators to recognize abnormal conditions and respond through traffic management actions, including adjustments to active Traffic Light Timing Plans at affected intersections.

### 3.6.2 Traffic metrics

AHCo utilizes a variety of traffic metrics to analyze traffic flow and the operation of Signalized Intersections in both real time and retrospectively. AHCo reviews the data to enhance the Signalized Intersection timing plan for all road users, giving priority first to pedestrians, then public transportation, and finally general vehicles. The near real time traffic metrics will be calculated in the MUTC and a BI platform for retrospective calculation and analysis.

### 3.6.3 Traffic Events

AHCo receives information about Traffic Events from various sources. The operators manage the Incidents and response to those Traffic Events by applying manual operations and executing predefined Response Plans.

## 4 Functional Components Requirements

### 4.1 General

The term "Functional Components" refers to MUTC elements that directly support and execute traffic management and control processes. The MUTC shall be comprised of the following primary functional components:

- a. Data Collection and Dissemination
- b. Data Processing and Analytics
- c. Traffic Management

Each of these components may include multiple modules, which are detailed in the subsequent sections of this document.

The MUTC shall be designed as a modular, building-block-based system, utilizing standard interfaces to support future growth. Each module shall expose its functions via open, well-defined APIs (REST/JSON, TMDD v3.1, or NTCIP XML as applicable) to enable integration, replacement, or extension of modules without requiring modification of other modules' internal code. Proprietary interfaces shall only be used with AHCo approval and must be accompanied by full documentation.

The MUTC shall support interfacing with external traffic control systems, urban data sources, and transportation management partners (e.g., other entities involved in traffic operations within the metropolitan area). While some of these interfaces are specified in this document, others may be defined and implemented in later phases. All such interfaces should be designed for ease of integration, minimizing the need for extensive software modifications or hardware adjustments.

The following diagram illustrates the MANTAM functional modules (highlighted in green) and the external systems and modules with which they may interface. Detailed descriptions of the required interfaces appear in Section 4.5.2.

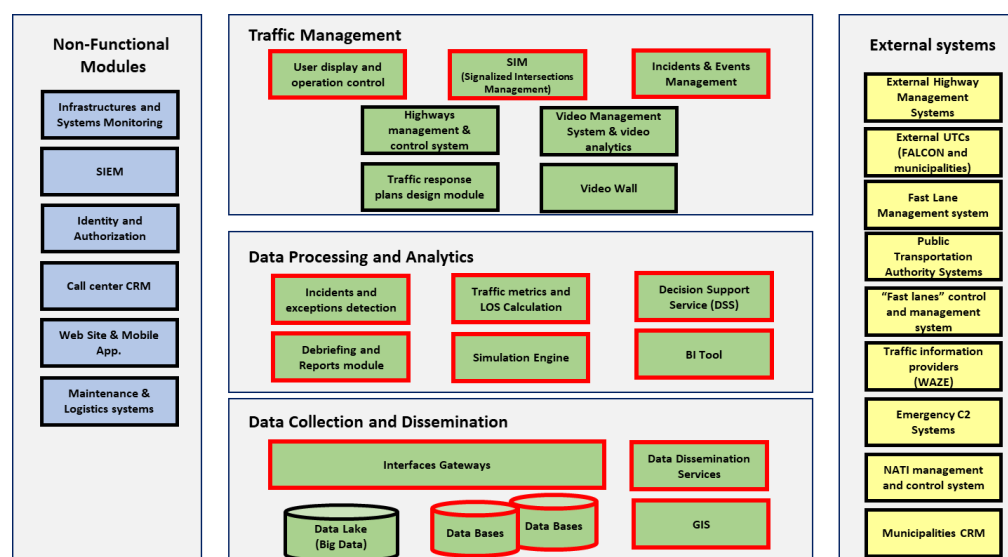

Figure 2 - MANTAM functional modules

- a. Green modules represent all the MANTAM functional modules; highlighted in the red frame are the MUTC modules.
- b. Blue components represent non-traffic functional modules, which will be provided by AHCo. The Supplier will be required to establish interfaces with these modules either for sending data or to use their services.
- c. Yellow modules represent external systems or system modules. These external systems are not part of the MUTC, some of these external systems already exist, while others will be incorporated in the future. The Supplier will be required to establish interfaces with these systems.

Remark: The terms "module" or "system's module" refers to functional capabilities implemented by software. A functional capability may consist of one or several modules. The above figure suggests a certain architecture breakdown of the system, but the Supplier may suggest another breakdown as long as these capabilities are implemented.

## 4.2 Multi-site support

### 4.2.1 General

The MUTC needs to support multiple traffic control centers concurrently, allowing users to manage each traffic control center separately from one another. See section 5.8 for details about technical requirements of the Multisite support. For chapter four (4), a Site entity will represent each traffic control center. Each Site will contain all the data regarding a specific traffic control center.

### 4.2.2 Each Site will have all the functionality requirements described in the SOW, including:

- 4.2.2.1 Manage the inventory of the Outstation Devices managed by the Site.
  - 4.2.2.2 Control and management capabilities of the Outstation Devices managed by the Site.
  - 4.2.2.3 Provide traffic, maintenance, and operational situational awareness across the Site.
  - 4.2.2.4 Manage the definitions of entities and properties of the System for the specific Site.
- 4.2.3 Specific Site requirements for Signalized Intersection are detailed at section 4.8.11.

## 4.3 MUTC traffic taxonomy

This section defines the taxonomy required for effective traffic management within the metropolitan road network, that is, the set of entities, definitions, and relationships that represent the structure and behavior of the transportation environment. These elements form the foundational infrastructure for conducting traffic control and management operations, particularly for the calculation of traffic metrics and LOS and the activation of Response Plans in response to dynamic or emergent scenarios across the network. The MUTC system shall support this taxonomy by enabling the definition and configuration of relevant entities, supporting the reception and dissemination of related information to and from external systems, and processing data associated with these entities in real-time.

### 4.3.1 Traffic entities

A traffic entity refers to a component of the road network that can be defined and dynamically updated within the system and associated with one or more performance metrics and LOS relevant to traffic management and control. Each entity may also be linked to a pre-defined Response Plan, enabling adaptive management. The MUTC is responsible for monitoring, analyzing, and managing the following types of traffic entities:

- 4.3.1.1 Vehicle road segment (VC link) - a road segment between two geographical locations in the road network, between which there is a directional flow of vehicles.
- 4.3.1.2 Lane of vehicles / lane of public transportation - a lane within a road segment separated by a dividing line. A lane may be defined as a link attribute or as a separate link. A lane represented as a separate link is typically defined in proximity to Signalized Intersections, where links are specified per traffic movement, as well as for dedicated public transportation lanes.
- 4.3.1.3 Vehicle route - a set of successive VC links. The route can be on the same road and includes crossroads.
- 4.3.1.4 Intersection or interchange – a crossroad of several links, contains traffic lights or without traffic lights in accordance.
- 4.3.1.5 Sub-network - a collection of links, routes, and intersections.
- 4.3.1.6 Public transport road segment (PT link) – a road segment between two geographical locations in the road network that has a directional flow of public transportation vehicles.
- 4.3.1.7 Public transportation route - a collection of successive PT links.

4.3.1.8 PT line – Public transportation line number.

4.3.2 Traffic definitions

4.3.2.1 Scenario - A given traffic situation of supply (the capacity of the roads), and of demand (mobility patterns of different types of road users).

4.3.2.2 Response Plan - a collection of traffic management activities to be implemented at an intersection, interchange, link, route, or sub-network.

4.3.2.3 Traffic Level of Service (LOS) – A standard measure used to describe the quality and efficiency of traffic flow on a roadway or at an intersection.

## 4.4 MUTC functional modules

This section describes the functional modules of the MUTC, logically organized into three layers, starting from the data layer and progressing up to the operational layer. Each functional module represents a distinct set of required system capabilities. The Supplier is not obligated to implement the system using the exact modular structure described here; however, they must ensure that the system fully delivers the capabilities and functionalities defined within each module. This modular breakdown serves as a reference framework for defining system requirements and required functionality.

4.4.1 Data collection and dissemination layer

The data collection and dissemination layer is responsible for collecting, organizing, and disseminating traffic data, traffic-related data, messages, and commands.

4.4.1.1 **Outstation data** – any data about the Outstation Device status, state and its operation such as Signalized Intersection's cycle operation information and faults, traffic detector status (working, fault), state (triggered, not triggered) and data (occupancy, count, speed, and etc.).

4.4.1.2 **Traffic data** – any data that is related to the description of the traffic flow, such as traffic entities and their corresponding metrics and LOS.

4.4.1.3 **Traffic-related data** – any supportive data for traffic management, such as Traffic Events, Traffic Management Devices inventory and maintenance status, forces' locations, environment conditions, etc.

4.4.1.4 **System audits** – all the activities performed by the system, Traffic Management Devices, and the users.

4.4.1.5 **Settings and traffic plans** – system settings, traffic settings (metrics parameters, thresholds, Response Plans, etc.)

4.4.2 Data processing and analytics layer

The data processing and analytics layer is responsible for creating insights into the data, both online and offline.

4.4.3 Traffic operation layer

The traffic operation layer is responsible for applying the insights into traffic operational processes and providing the user front-end for all those operational capabilities – traffic lights management, events handling, Response Plans configuration, traffic policies definitions, etc.

The following diagram represents the functional modules divided into different layers:

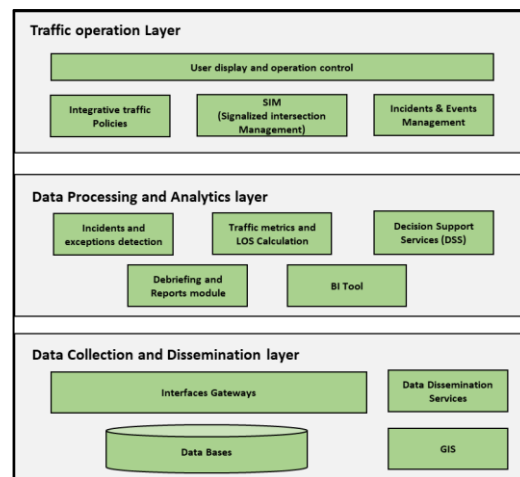

Figure 3 - Functional modules layers

## 4.5 Data collection and dissemination layer

### 4.5.1 General

The modules within the Data Collection and Dissemination Layer are responsible for acquiring, aggregating, fusing, and organizing traffic data within the internal databases of the MUTC. These modules also manage the distribution of processed data to relevant clients, including internal MUTC modules, the AHCo Data Warehouse (DW), Data Lake, external systems, and end-user clients. In addition, this layer supports the C2C (Center-to-Center) and C2F (Center-to-Field) interfaces between the MUTC, other traffic management systems, and field-level Traffic Management Devices, particularly the Traffic Light Controllers.

Data dissemination shall contain several types of data, such as:

- 4.5.1.1 Data entities – Dissemination of specific data entities.
- 4.5.1.2 Data layers – Dissemination of entire data layers.
- 4.5.1.3 Notifications and warnings – Generation and dissemination of notifications and warning messages based on predefined triggers or specific requests - such as sending Traffic Incident alerts to traffic management personnel. The system shall enable the distribution of messages via SMS and email, utilizing a connection to the AHCo exchange server. Operators shall have the capability to define and manage messaging templates tailored to specific client groups.
- 4.5.1.4 Commands – Sending commands to Traffic Management Devices (Traffic Light Controllers) and request messages to traffic management systems (such as HTMS).

Following are the explanations for each of the modules:

### 4.5.2 MUTC Interfaces

#### 4.5.2.1 General

The MUTC will be integrated into the broader MANTAM ecosystem, which encompasses various internal systems, Traffic Management Devices, external systems, and supporting infrastructures. A combination of interface gateways will be used to facilitate interfaces with these diverse systems and devices, all of which contribute to traffic data exchange and control operations.

Data collected via these interfaces will be stored within the MUTC's internal databases. The MUTC shall utilize two types of databases: a real-time database to manage active transactions and a historical/archive database for long-term storage, categorization, and support of advanced analytics.

The data organization must support efficient abstraction, extraction, and querying. The use of modular gateways is encouraged to promote flexible and scalable system architecture. However, the final implementation shall follow the architecture proposed by the Supplier, which must be presented and

approved by AHCo during the quality evaluation interview (refer to Section 5.2.4 in Volume A “Terms of Tender” and Item #7 in Volume D - Quality Measurement).

The main interfaces of the MUTC are illustrated in the following figure. Interfaces marked in red represent optional interfaces that may or may not be included in the final system scope, subject to ordering by AHCo.

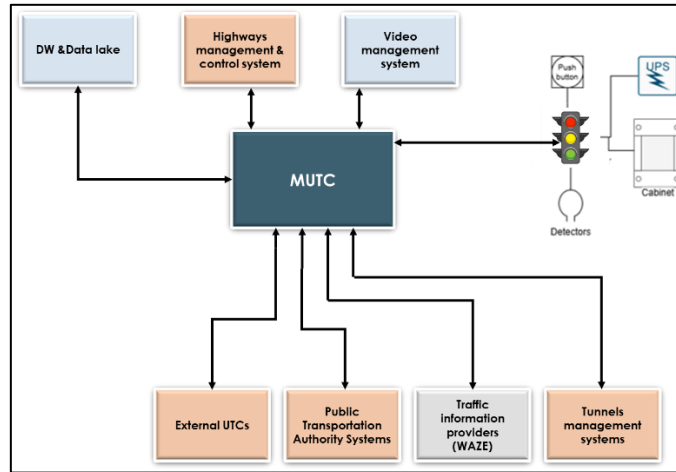

*Figure 4 - MUTC Interfaces*

#### 4.5.2.2 Interface management

4.5.2.2.1 The MUTC shall support comprehensive interface management capabilities, ensuring robust and secure operation of all data exchanges with internal and external systems and sensors. Specifically, the system shall support the following functionalities:

- Data Flow Control – The ability to programmatically open and close interface connections, based on operational needs or system conditions.
- Data Gathering Rate Control – The ability to define and dynamically adjust the frequency, sampling rate, and volume of data collected from each connected source or interface.
- Data Filtering – Filtering of incoming data streams according to configurable parameters defined in the message metadata, allowing for targeted processing and improved efficiency.
- Load Balancing – The capability to regulate both incoming and outgoing data traffic, including setting rate limits and request intervals per interface, to prevent congestion or overload.
- ID Management – Traceability of all incoming messages by maintaining the source identification (ID) associated with each message, supporting accountability and data integrity.
- Interface Monitoring – Continuous monitoring of the status and health of each interface, with real-time status reporting to the Network Operations Center (NOC) and Security Operations Center (SOC). The monitoring process shall include detection of abnormal data loads or patterns that may indicate potential Denial-of-Service (DDoS) attacks.

4.5.2.2.2 The system engineer shall be able to define the reliability of each data source. The purpose of the data source reliability is for correct weighting in the MUTC data fusion and correlation. The system administrator will set the reliability value, which will be taken into account by the MUTC in the fusion process and metrics calculations.

4.5.2.2.3 Each interface gateway shall be responsible for identifying and resolving any discrepancies in the data received from its respective source.

4.5.2.2.4 The Supplier shall utilize standard, off-the-shelf management tools to support the interface management capabilities described in this section. These tools shall be detailed as part of the MUTC system architecture presentation, which will be delivered during the quality evaluation interview (refer to Section 5.2.4 in Volume A “Terms of Tender” and Item #7 in Volume D - Quality Measurement).

#### 4.5.2.3 Interfaces C2C protocols

- 4.5.2.3.1 The MUTC shall support Center-to-Center (C2C) interfaces for interoperability with external traffic operation and traffic management systems.
- 4.5.2.3.2 These interfaces are intended to enable coordinated traffic management, data exchange, and operational synchronization across organizational and jurisdictional boundaries.
- 4.5.2.3.3 The MUTC C2C interface framework shall be protocol-agnostic, allowing the exact communication protocol(s) to be selected and implemented per specific interface, based on the requirements, capabilities, and architectural constraints of the external system.
- 4.5.2.3.4 The MUTC may support the following C2C interface standards and technologies, as applicable to each interface:
- NTCIP 2306
  - TMDD 3.03d or above
  - DATEX II
  - Secure HTTPS REST API
- 4.5.2.3.5 The detailed selection of protocols, message sets, versions, and data mappings for each C2C interface shall be defined during the system design of each interface and finalized in the corresponding Interface Control Document (ICD), to be approved as part of the CDR. Later protocol versions may be adopted where applicable.
- 4.5.2.3.6 The following sections specify the interface gateways that the MUTC shall support in Block 1, together with their functional workflows. These specifications are provided to support the Supplier's effort estimation and solution design and are preliminary. Final interface definitions, including protocols, message structures, security mechanisms, and operational workflows, shall be completed and approved during the CDR. Additional interfaces may be ordered as workloads and are described in section 9.2.4.
- 4.5.2.4 SIM Interface gateway
- The MUTC will interface with Traffic Light Controllers to receive near real-time information regarding their operational status and health, and to transmit instructions and control commands. These interactions will be managed by the SIM module. The full scope of required functionalities and actions related to this interface is detailed in Section 4.8.6.
- 4.5.2.4.1 As of the date of publication of the Tender, the SIM interface gateway shall support the following:
- Management and control of the Actros Traffic Light Controllers type, provided by the Menorah company, based on the DVI35 protocol described in Volume E1 Appendix 5 – DVI35 protocol type B. It is the responsibility of the Supplier to coordinate with the Traffic Light Controller supplier the exact ICD.
  - Management and control of the ST950 Traffic Light Controller type, provided by the R.S. company, based on the DVI35 protocol described in Volume E1 Appendix 4 – DVI35 protocol type A and Volume E1 Appendix 5 – protocol type B. It is the responsibility of the Supplier to coordinate with the Traffic Light Controller supplier the exact ICD.
  - Management and control of the EC2 and Flownode Traffic Light Controller types, provided by the Ariel Wimasor company, based on the DVI35 protocol described in Volume E1 Appendix 5 – DVI35 protocol type B. It is the responsibility of the Supplier to coordinate with Traffic Light Controller supplier the exact ICD.
  - Management and control of the ITC-2, and ITC-3 traffic lights controller types, provided by the IPI company, based on the Modbus protocol described in Volume E1 Appendix 6 – Modbus protocol & Volume E1 Appendix 15 – Modbus protocol for ITC3 respectively. It is the responsibility of the Supplier to coordinate with the Traffic Light Controller supplier the exact ICD.
- 4.5.2.4.2 AHCo is in the process of standardizing communications with Traffic Light Controllers through a single interface protocol to be used by all Traffic Light Controllers. The goal is to incorporate all the information and commands listed in this SOW into the unified protocol. The unified protocol will be based on the DVI35 protocol listed above. Documentation of the unified protocol will be provided during the PDR phase.
- 4.5.2.4.3 Each Traffic Light Controller used by AHCo supports one of the interface protocols listed above. The SIM module must support all the interface protocols.

- 4.5.2.4.4 The Traffic Light Controller allows the storing and operating of at least 16 plans. For each plan, it will be possible to save and use 200 parameters of at least one byte each (at least 200 bytes per plan).
- 4.5.2.4.5 The Traffic Light Controller allows the storing and operating of at least 32 plans. For each plan, it will be possible to save and use 100 parameters of at least one byte each (at least 100 bytes per plan).
- 4.5.2.4.6 In Traffic Light Controllers managing two or more intersections, the Traffic Light Controller allows the storing and operating of at least 32 plans. For each plan, it will be possible to save and use 100 parameters of at least one byte each (at least 100 bytes per plan).
- 4.5.2.4.7 The MUTC shall not impose limitations on the scalability or complexity of traffic light plan designs. This includes but is not limited to, restrictions on the number of decision points, plan parameters, detectors, or any other configurable elements within a traffic signal plan. The system shall support the development and integration of traffic control strategies of varying scale and complexity without architectural or functional constraints.

#### 4.5.2.5 Road users' application gateway - Waze

Waze supplies real-time information about traffic congestion and events that impact road conditions. This data is derived from two primary sources: reports submitted by Waze users (referred to as Wazers) and external data providers. Wazers contribute user-reported Traffic Events - detailed reports on current traffic disruptions, road hazards, or environmental conditions. In addition, Waze generates automated alerts for unusual traffic patterns, identifying anomalies that significantly deviate from expected conditions based on historical norms for a given location, day, and time. These insights provide valuable context for dynamic traffic management and selecting Response Plans.

- 4.5.2.5.1 The MUTC shall periodically retrieve traffic data from Waze. The data retrieval interval shall be configurable by the system administrator to accommodate operational and performance requirements.
- 4.5.2.5.2 The MUTC shall retrieve the following data types from Waze:
  - General Information – Metadata such as the timestamp of data collection and the geographical area from which the data was obtained.
  - Traffic Alerts – User-reported Traffic Events submitted by Waze users. For each reported Traffic Event, Waze provides a reliability score, which reflects the confidence level of the report. The MUTC shall allow the filtering of alerts based on this reliability score, and support setting a minimum reliability threshold per Traffic Event type dynamically, without requiring a system restart.
  - Traffic Jams – Information on traffic slowdowns, calculated by Waze based on aggregated user location and speed data.
  - Traffic data – Waze provides average travel time and information for defined Waze links. The MUTC shall align Waze links with the corresponding MUTC VC links whenever the links do not overlap.
  - Additional Data – Other data types may be incorporated into the interface specification up to the System Design Review (SDR) phase.
- 4.5.2.5.3 The MUTC shall analyze traffic data retrieved from Waze and integrate it with other traffic data sources available to the system to calculate LOS and congestion levels.
- 4.5.2.5.4 Geographic Coverage Configuration - The MUTC shall retrieve Waze traffic data for predefined geographic Waze links via polygons corresponding to each metropolitan area. These polygons and links will be defined and provided by AHCo during the system Design Review phases. Users shall be able to define, and associate Waze links based on the corresponding VC links defined in the MUTC
- 4.5.2.5.5 Interface Protocol - All data exchange with Waze shall be implemented using the REST API provided by Waze.
- 4.5.2.5.6 Information about Waze traffic feed can be found on Google support - [link](#). and specifically at Traffic view feed specifications - [link](#)

#### 4.5.2.6 HTMS Interface gateway

The MANATM HTMS is the SICE SIDERA system. The interface between the MUTC and the SIDERA HTMS shall enable coordinated operational exchange of traffic-related information. The interface will be based on the following requirements.

##### 4.5.2.6.1 General

- Both systems shall share their traffic situation awareness, including traffic entities (unique identity and location), relevant traffic metrics and Traffic Events.
- Traffic entities (such as links and routes) shall be synchronized based on an agreed list. Each traffic entity must have a unique identifier.
- The HTMS system shall provide the MUTC with inventory and maintenance status of controlled field devices.
- The MUTC shall be able to request publication of messages on VMS signs controlled by the HTMS.

#### 4.5.2.6.2 Interface protocol

- NTCIP 2306 standard for XML Message Encoding and Transport in Centre-to-Centre Communications (NTCIP C2C XML). [link](#)
- TMDD 3.03d or above as coordinated with the HTMS supplier during the design phase of the MUTC. [link](#)
- REST API for messages that are not supported by the above protocols.

The workflow between HTMS and the MUTC shall implement the following:

- 4.5.2.6.3 Each system shall notify the other about the operational status of the interface.
- 4.5.2.6.4 The MUTC shall send an inventory of links, Traffic Light Controllers, and detectors. The exact list will be defined during the CDR.
- 4.5.2.6.5 The MUTC shall send information about Traffic Events as they are created in the MUTC. The Traffic Events characteristics to be sent by the MUTC will be defined during the CDR.
- 4.5.2.6.6 The MUTC shall send the status and state of the links (metrics, LOS, blocked links, etc.), Traffic Light Controllers (working, failures, current plan, blinking-yellow state, etc.), and detectors (occupancy, volume, etc.). The exact information will be defined during the CDR.
- 4.5.2.6.7 The MUTC shall receive the state and status from the HTMS about links. The MUTC shall be able to display the information on the traffic situation picture in a dedicated layer.
- 4.5.2.6.8 The MUTC shall receive information about Traffic Events from the HTMS and display them on the traffic situation picture.
- 4.5.2.6.9 The MUTC shall receive inventory from the HTMS about links and Interchanges (approximately 30), detectors, VMS (approximately 25), LCS (approximately 500), VPS (approximately 80) and traffic barriers and display the elements on the traffic situation picture in a dedicated layer.
- 4.5.2.6.10 The MUTC shall receive a request from the HTMS to change the signal timing plan operated by the relevant Traffic Light Controller (one of a set of predefined traffic light plans). The predefined traffic light plans may differ, for example, in the green time allocated to the different signal groups (used for example to relieve congestion on exits from the highway) or differ in the participating signal groups (used for example to close the entrance to the highway or to close a lane). According to the request, the MUTC shall be able to implement a suitable traffic light plan in the Traffic Light Controller. Compliance with the HTMS request may be performed automatically or manually based on the MUTC traffic engineer definition.
- 4.5.2.6.11 The HTMS shall be able to receive requests from the MUTC to set a message on a VMS sign controlled by the HTMS. The HTMS will decide by its internal rules if to accept the request and to set the requested message on the VMS. The MUTC will allow users to set messages on HTMS's VMS in the following techniques:
  - Executing predefined rules which include instructions to set messages on HTMS' VMS.
  - Selecting a VMS and setting manually a message. Traffic engineers may apply free text messages and create a predefined message directory for each VMS. Traffic operators shall set a message only from the predefined message directory.

A full list of all messages and workflow between the MUTC and the HTMS shall be defined during the CDR.

#### 4.5.2.7 Public transportation authority systems gateway

- 4.5.2.7.1 The gateway shall collect data public transportation data from the Israeli National Public Transport Authority dedicated service. The service publishes static information based on GTFS format and near real-time information based on the SIRI-SM protocol (Part of the European SIRI protocol).

4.5.2.7.2 The static information includes the permit data (the list of public transportation operators in Israel, lines, schedules, order of stations, and the route of the line, etc.) for the coming weeks. Further information can be found at

\* [מידע סטטי - GTFS הרשות הארצית לתחבורה ציבורית | GTFS \(www.gov.il\)](http://www.gov.il)

\* [GTFS Developer Information](#)

4.5.2.7.3 The near real-time information includes the line number, trip ID, vehicle number, vehicle real-time tracking (location) and estimated time for the vehicle to arrive at the station. Further information can be found at

\* [מידע בזמן אמת – מידע למפתחים](#)

\* SIRI-SM protocol - [ICD\\_SM\\_28\\_31.pdf \(www.gov.il\)](#)

4.5.2.8 Video analytics module gateway

The MUTC will include an interface with DFS (Data From the Sky video analytic system). The analytics performed on the video generated by the traffic cameras may provide the following data per traffic camera:

4.5.2.8.1 The MUTC shall receive the following basic data per lane – data will be generated every 30 sec or less, and include at least the following data:

- Camera ID
- Time of report
- Lane
- Average Speed (kph)
- Occupancy (%)
- Headway (sec)
- Number of vehicles per classification– according to at least the following 6 classes: Motorcycle, Private Vehicle, Commercial Vehicle, Truck, Bus, and Other. Additional types \ subtypes may be provided.

4.5.2.8.2 The above data shall be used for traffic metrics calculation by the MUTC and may also be used as data for Traffic Incident detection in addition to other data as described in the following sections.

4.5.2.8.3 The video analytics may also provide automatic Traffic Incident detection capabilities, which may include:

- Detection of accidents.
- Detection of stopping vehicles.
- Detection of obstacles on the road.
- Detection of bicycles near the highway including the road shoulder.
- Detection of humans near the highway including the road shoulder.
- Congestion conditions \ slow traffic according to predefined limits.
- Very "high speed" vehicle according to predefined limits.

4.5.2.8.4 The alerts will be transferred from the video analytic module to the MUTC. The alerts may include Traffic Incident position and classification according to available data which is generated by the video analytic module or added by the user to enable further processing by the MUTC modules and operators.

4.5.2.8.5 The MUTC user shall be able to control and configure all the data received from the video analytic module or only the data from specific traffic cameras.

4.5.2.8.6 In the case of scheduled Traffic Events, the user will be able to disable receiving specific types of alerts from specific cameras related to the location of the scheduled Traffic Event.

#### 4.5.2.9 Video management system gateway

AHCo is in the process of deploying a large number of traffic surveillance cameras (CCTV) across metropolitan roads, including both highways and urban streets. Currently, AHCo utilizes two (2) separate Milestone Video Management System (VMS) installations for video monitoring, display, and camera control. The MUTC shall be capable of establishing and maintaining simultaneous interfaces to both instances of Milestone VMS based on the following requirements.

4.5.2.9.1 The MUTC shall receive from the VMS, the inventory of traffic cameras – operational status, position, and FOV (Field of View).

4.5.2.9.2 The MUTC shall receive live or recorded video streaming from the VMS as broadcast from a CCTV.

4.5.2.9.3 The MUTC shall allow to display live and recorded video streams from each traffic camera within the system interface, aligned to the geographic location and field of view (FOV) of the selected camera.

4.5.2.9.4 The Users will be able to remotely control the PTZ (Pan-Tilt-Zoom) cameras managed via the VMS, allowing the operator to move a camera to a designated position and automatically display the relevant video feed associated with a specific location or event.

4.5.2.9.5 The MUTC will be able to issue a request to “return to default position” for each PTZ camera, either automatically or upon operator command.

4.5.2.9.6 Control of the traffic CCTV shall be implemented via the ONVIF protocol and/or through the VMS SDK, ensuring compatibility with existing and future deployments. Currently the ONVIF supports Profiles S, T, G and M.

#### 4.5.2.9.7 Traffic Camera display

The MUTC display shall enable to open of a video stream from every selected road camera to be displayed on the TSPD, control it (if authorized), and perform every manipulation the video area system enables (frame saving, target marking, etc.).

#### 4.5.2.10 Implementing an interface with a maintenance and logistic support system

The AHCo Maintenance and Logistics Support System is responsible for managing all logistics and maintenance operations across the MANTAM ecosystem. The interface between the MUTC and the maintenance system shall be implemented using an API published by the maintenance system or the generic API published by the MUTC. AHCo will decide which API to use. The interface shall support:

4.5.2.10.1 Maintenance Event Reporting – The MUTC shall detect and report Maintenance Events related to Outstation Devices that it directly manages, such as Traffic Light Controllers, signal lamps, UPS units (connected to the Traffic Light Controller), detectors and cellular/LTE routers, to the AHCo maintenance system. Events that indicate a malfunction or require field intervention shall be automatically transferred via the defined interface.

4.5.2.10.2 Internal System Malfunctions - The MUTC shall also report any internal malfunctions (e.g., software errors, and hardware faults within the control center infrastructure) to the HxGN EAM system.

4.5.2.10.3 Maintenance Status Updates from the maintenance system - The maintenance system shall provide status updates regarding the handling and resolution of Maintenance Events. These updates shall be integrated into the Incidents and Events Management Module of the MUTC to support a comprehensive operational view.

4.5.2.10.4 Interface Specification - The interface between the MUTC and the AHCo maintenance system shall be formally defined during the System Design Review (SDR) phase.

#### 4.5.2.11 Google Traffic Data Interface

4.5.2.11.1 The Supplier shall establish an interface to Google traffic data through its Road Management Insights (RMI) Pub/Sub interface.

4.5.2.11.2 The RMI interface shall retrieve traffic data for the traffic links defined by AHCo at intervals of once every two (2) minutes.

4.5.2.11.3 The RMI interface shall provide at least the following data items for each link:

- Average velocity
- Traffic volume

- Traffic link geometry in GIS format

4.5.2.11.4 The Supplier shall implement all required mechanisms for retrieval, mapping, processing, storage, and monitoring of the data received through this interface.

4.5.2.11.5 The Supplier shall ensure that each received record is correctly associated with the relevant link in the System.

#### 4.5.3 Data Dissemination Services Module

4.5.3.1 The MUTC shall include a data dissemination module responsible for distributing several types of data such as raw data, processed data, messages, and notifications, stored in the internal databases to all authorized consumers.

4.5.3.2 Data consumers include, but are not limited to:

- MUTC users – for receiving operational messages and system notifications.
- AHCo Data Warehouse (DW) and Data Lake – via an Extract, Transform, Load (ETL) process.

4.5.3.3 As part of the integration with the AHCo DW and Data Lake, AHCo will implement an ETL process to extract data from the MUTC databases. The Supplier shall provide all necessary documentation and access to support the development of this process. The ETL mechanism will perform periodic read operations to retrieve the most up-to-date data and populate the DW and Data Lake accordingly. The detailed structure of the database views to be accessed by the ETL process will be defined during the Critical Design Review (CDR) phase.

#### 4.5.3.4 Generic API

The service should also provide a generic REST API service to web clients which will be used to disseminate data on the AHCo website, external clients and to public applications, under AHCo authorization.

#### 4.5.4 Geographic Information System (GIS) Services

4.5.4.1 The MUTC shall include a GIS service to support the visualization, creation, editing, and execution of geo-based operations. This service shall enable interaction with system information through a geographic user interface and shall allow the activation of geo-processes and other MUTC functional components based on spatial data.

4.5.4.2 The Supplier shall ensure that geographic data is managed in both the New Israel Grid (ITM) and the WGS84 coordinate reference systems. The MUTC shall support runtime switching between these systems and optionally allow for simultaneous display of both.

4.5.4.3 AHCo may provide raster and vector geographic data layers covering relevant regions within Israel. The Supplier shall be responsible for integrating and adjusting these layers for use within the MUTC GIS, and for performing ongoing updates to the layers in accordance with AHCo's requirements.

4.5.4.4 The MUTC shall support the export of geographic information layers in standard international formats, such as Shapefiles, with support for both the New Israel Network Datum (ITM) and WGS84 coordinate systems.

4.5.4.5 GIS services shall be delivered through an on-premises GIS server, installed by the Supplier on the OT network.

#### 4.5.5 Internal Databases - Storage, management, and visualization

4.5.5.1 The MUTC databases shall store a wide range of data types as outlined above, encompassing operational, configuration, and analytical datasets. The databases shall support both short-term (real-time/transactional) and long-term (historical/archival) storage, as required to fulfill the system's functional, monitoring, and analytical requirements.

4.5.5.2 The data management framework shall enable efficient indexing, retrieval, and correlation of information across different data domains, including traffic flow, sensor inputs, Traffic Incidents, control plans, and external data sources. The system shall support data access and utilization by both internal MUTC modules and external analytical engines, such as BI platforms and future AI engines, to enable advanced analytics, predictive modeling, and decision-support functions.

- 4.5.5.3 The database shall maintain structured and indexed datasets representing both internal and external data sources, including but not limited to traffic information from third-party providers (such as Google, Waze, and other authorized sources), field device data, event records, Response plans, metrics and LOS. It shall support efficient queries and data aggregation functions to facilitate real-time and historical visualization.
- 4.5.5.4 The overall data management architecture shall ensure data integrity, synchronization across modules, and compliance with defined data retention and access control.
- 4.5.6 System audit
  - 4.5.6.1 The MUTC shall log every operation performed on any Traffic Management Device. Each log entry shall include the identity of the initiator, the date and time of execution, a complete description of the operation, and the values before and after the operation. For operations executed automatically, the log shall additionally record the triggering cause, such as a weekly schedule, a predefined rule name, or an adaptive mode module.
  - 4.5.6.2 The MUTC shall monitor and log any operation performed by users, like changing values and metadata of the system entities.
  - 4.5.6.3 The logs will store at least the following information
    - 4.5.6.3.1 Name of the initiator.
    - 4.5.6.3.2 Date of operation.
    - 4.5.6.3.3 Description of the operation.
    - 4.5.6.3.4 Before and after values.
  - 4.5.6.4 Operation logs shall be associated with the affected system entities or objects and shall be displayed in reverse chronological order, from the most recent entry to the earliest.
  - 4.5.6.5 Audit logs shall be retained for at least seven (7) years, of which at least the most recent 12 months shall be available for online access within the MUTC, while older records may be stored in an archive, provided they remain searchable and retrievable by authorized users.
  - 4.5.6.6 The logs will be accessible to the BI and to the Data Lake for reports.
- 4.5.7 Data localization
  - 4.5.7.1 The MUTC shall support localization of displayed data based on the Israel locale, including date and time formats, local time calculation, and currency representation where applicable.
  - 4.5.7.2 The system shall use metric measurement units, specifically meters and kilometers.

## **4.6 Data Processing and Analytics Layer**

### **4.6.1 General**

The Data Processing and Analytics Layer comprises several modules designed to generate data-driven insights and provide operational recommendations to support traffic management activities.

The Supplier may, where appropriate, utilize advanced analytical techniques in the implementation of the modules described in this section, including statistical analysis, simulation methods, artificial-intelligence or other data-driven analytical approaches, in order to enhance traffic analysis and operational insights. The use of such analytical techniques shall not derogate from the functional requirements defined in this chapter and shall remain fully compatible with the system's operational logic and user control mechanisms.

### **4.6.2 Traffic metrics and Level of Service (LOS) calculation**

- 4.6.2.1 This module shall be responsible for calculating traffic performance metrics and Level of Service (LOS) values for defined traffic entities. The calculation of each metric shall be conditional on the availability, relevance, and quality of data associated with the specific traffic entity. The system should provide operators with the ability to configure which metrics are calculated for each traffic entity and for defined time periods, allowing for flexible, data-driven monitoring tailored to operational needs.

4.6.2.2 The following table describes the currently available data sources and their characteristics. The Supplier may assume that minor variations in data quality and retrieval rates may occur, these will be reviewed and finalized by the CDR stage.

Data Source	Parameter	Unit of Measurement	Retrieval Rate
Traffic Light Controller	Cycle time	Seconds	Each cycle
Traffic Light Controller	Green times for each movement in each signal cycle	Seconds	Each cycle
Traffic Light Controller	Signal indication - The state of all traffic signal lights, for all movements, at a given moment (Red/Yellow/ Green).	On\off	Each second
Traffic light detector	Actuated\Not-actuated detector	Yes\no	Each second
Traffic light detector	Vehicle counts (Actuation counts for each movement detector)	Number	Each cycle
Traffic light detector	Occupancy (Total time detector is occupied divided by cycle time) * 100. Calculated for each movement detector.	Percentage	Each cycle
Waze	Average velocity per link	Km/h	Every 2 minutes*
Waze	Average travel time per link	Seconds	Every 2 minutes*
Waze	Alerts - Alerts represent short, structured data messages indicating anomalies, hazards, or operational impacts that may influence traffic flow, safety, or routing decisions.	Location and alerts metadata	Every 2 minutes*
Waze	Delay - Actual travel time minus expected normal travel time	Seconds	Every 2 minutes*
Google	Average velocity	Km/h	Every 2 minutes
Google	Traffic volume	Counts	Every 2 minutes

*Table 5 - Available data sources*

\* The supplier may assume time deviations of approximately 2–5 minutes.

4.6.2.3 Traffic metrics serve as the foundation for situational awareness in road network management. By continuously measuring metrics, the MANTAMs can maintain a real-time picture of network performance. When a major degradation in metrics occurs, such as a sudden drop in travel speed, abnormal increases in travel time, or deterioration of Level of Service (LOS), the system shall automatically raise alerts and may trigger the activation of predefined Response Plans. The specific usage of metrics and LOS are described later in the document.

4.6.2.4 Calculated traffic metrics and Level of Service (LOS) values shall be linked to their corresponding traffic entities and presented either as visual data layers within the traffic situation picture or as contextual information accessible when interacting with a specific entity. This flexible representation shall enable operators to intuitively assess performance conditions across the network and support informed, real-time decision-making.

4.6.2.5 Traffic metrics may also be obtained from external sources, if connected to the MUTC, including roadside detectors, video analytics systems, and Waze. Data collected from these external sources may require filtering and correlation to ensure consistency, eliminate duplication, and resolve discrepancies across datasets.

4.6.2.6 The system shall provide the capability for authorized users to define, configure, and modify the data source or combination of sources used for each metric calculation. This configuration shall allow operators to select the most relevant or reliable source per metric (e.g., travel time, speed, congestion level) based on operational priorities, data availability, or quality assessments.

4.6.2.7 Traffic metrics shall be calculated over a variety of user-defined time intervals, including:

4.6.2.7.1 Instantaneous values

4.6.2.7.2 Traffic signal cycles

4.6.2.7.3 Short intervals (e.g., minutes)

4.6.2.8 The time intervals required for calculating each traffic metric, for each traffic entity, shall be based on the intervals outlined in the table below. These intervals serve as preliminary definitions and will be reviewed, refined, and finalized by the Critical Design Review (CDR) stage.

- 4.6.2.9 By default, all traffic metrics shall include both the absolute value of the measured parameter and the variance from the nominal (baseline) value for the same traffic entity and corresponding time period. This dual representation will support comparative analysis and enhance the operator’s ability to detect anomalies or performance deviations.
- 4.6.2.10 The baseline value shall represent the expected or typical condition for each metric under normal operating circumstances. It shall be systematically defined and configurable according to one or more of the following criteria:
- 4.6.2.10.1 The system shall calculate baseline values using historical data aggregated over a predefined rolling period, ensuring alignment with the same day of week and time interval. The baseline shall incorporate only historical records representing comparable operational contexts, including peak and off-peak demand levels, holidays, and other special-condition days, in order to establish an accurate normative reference for real-time comparison.
- 4.6.2.10.2 The baseline may also be retrieved from external BI systems, such as the AHCo BI platform, through standard interfaces including REST API endpoints or other supported data-extraction services provided by the BI system.
- 4.6.2.11 The system shall allow authorized users to configure and update the baseline definition per metric, per location, and per time segment (e.g., peak/off-peak, weekday/weekend). The configuration shall include control over parameters such as the calculation window and exclusion of outliers or abnormal conditions (e.g., special events, roadworks).
- 4.6.2.12 The calculation engine should be designed to function robustly, regardless of fluctuations in data availability over time. In cases where certain data is not yet available during development stages, the Supplier shall utilize simulated data to validate system performance and compliance during the FAT and SAT.
- 4.6.2.13 Calibration tool for LOS calculation thresholds - The calculation of traffic LOS within the MUTC is dependent on predefined threshold values separating LOS levels; however, in order to maintain accuracy and alignment with observed traffic behavior, the system shall support dynamic calibration of these thresholds based on traffic analytics. The Supplier shall provide a LOS threshold calibration tool or mechanism that enables authorized users to define, modify, activate, and manage LOS threshold values per traffic metric and operational context, without requiring software changes. All threshold modifications shall be versioned, auditable, and traceable to the user, timestamp, and justification, and shall be applied consistently across real-time monitoring, alerts, and reports, with detailed calibration workflows and governance finalized during the PDR and CDR phases and approved by AHCo.
- 4.6.2.14 During system setup, installation, and the trial-run phase, a set of traffic metrics and LOS values will be defined for selected traffic entities. These definitions will be based on each entity’s relevance to traffic management and the availability of supporting data.
- 4.6.2.15 For certain metrics, the description provides a reference formula intended to clarify the expected calculation logic and the core parameters that must be considered. The Supplier may propose an alternative formula, provided that it adheres to the same fundamental input parameters, reflects the same conceptual logic, and produces results consistent with the defined metric objectives. AHCo reserves the right to accept, reject, or refine and finalize the proposed formula jointly with the Supplier by the CDR.

The table below outlines the set of traffic metrics that the system is expected to calculate and manage.

4.6.2.16 Performance metrics

#	Traffic metric	Description	Time period for calculation	Traffic entities
1	Velocity	As retrieved from Waze and aggregated according to the defined route.	2 min	VC link, VC route
2	Travel time	As retrieved from Waze and aggregated according to the defined route.	2 min	VC link, VC route
3	Volume	Traffic volume is defined as the total number of vehicles counted for each movement over a user-specified time interval, calculated by aggregating vehicle counts collected across several traffic light cycles.  <b>Formula:</b>	Each cycle	Intersection – for each movement

		<p><math>C</math> = number of signal cycles included in the user-defined aggregation window.</p> <p><math>V_{m,c}</math> = number of vehicles counted for movement <math>m</math> during cycle <math>c</math>.</p> <p><math>Volume_m</math> = total volume for movement <math>m</math> over the defined time interval.</p> $Volume_m = \sum_{c=1}^C V_{m,c}$		
4	Congestion intensity and LOS	<p>Congestion intensity for each link shall be derived from the ratio between the actual measured travel time and the estimated free-flow travel time. For links situated immediately upstream of a Signalized Intersection, the congestion calculation shall also account for induced delays, derived from the red-time duration applicable to the relevant movement.</p> <p>The module shall report the Level of Service (LOS) derived from the calculated congestion level, using the following classifications:</p> <p>LOS 2: Free Flow  LOS 3: Forced Flow  LOS 4: Congested Conditions</p> <p><b>Formulas:</b></p> <p>If <math>\frac{ActualTT_l^T}{EstimatedTT^l} &lt; LOS3Factor^l</math> then <math>LOS^l = 2</math></p> <p>Else If <math>\frac{ActualTT_l^T}{EstimatedTT^l} \geq LOS3Factor^l</math> and <math>\frac{ActualTT_l^T}{EstimatedTT^l} &lt; LOS4Factor^l</math> then <math>LOS^l = 3</math></p> <p>Else If <math>\frac{ActualTT_l^T}{EstimatedTT^l} \geq LOS4Factor^l</math> then <math>LOS^l = 4</math></p> <p><b>Where:</b></p> <ul style="list-style-type: none"> <li>• <math>l</math> – link identifier</li> <li>• <math>T</math> – reporting timestamp</li> <li>• <math>ActualTT_l^T</math> – the actual travel time on link <math>l</math>, reported at timestamp <math>T</math></li> <li>• <math>EstimatedTT^l</math> – the estimated free-flow travel time on link <math>l</math></li> <li>• <math>LOS3Factor^l, LOS4Factor^l</math> – the threshold factors for LOS levels 3 and 4 on link <math>l</math></li> </ul> <p>The LOS threshold factors for each link shall be defined and provided by AHC0, following a calibration process.</p>	2 min	VC link, VC route, sub-network
5	Congestions anomalies	<p>The congestion anomaly indicator is designed to identify unusual or abnormal congestion conditions on each link. The calculation process includes two main components:</p> <p>Daily update of historical baseline values.</p> <p>Evaluation of anomaly levels for current measurements.</p> <p>Daily update of historical baseline values: Baseline values of congestion intensity shall be updated at the end of each day, for every link.</p> <p>The baseline shall be maintained for every combination of:</p> <p>15-minute time interval, and  day type (e.g., weekday, weekend, holiday)</p> <p>The baseline shall be computed using data from the previous 3 months.</p> <p>For each link and each time slot, the system collects all valid congestion measurements from the last 3 months:</p> $X_1, X_2, \dots, X_N$ <p>Mean calculation (Historical expected value):</p>	2 min	VC link, VC route, sub-network

		$\mu = \frac{1}{N} \sum_{i=1}^N X_i$ <p>Standard deviation:</p> $\sigma = \sqrt{\frac{1}{N-1} \sum_{i=1}^N (X_i - \mu)^2}$ <p>The pair <math>(\mu, \sigma)</math> represents the historical performance distribution for this segment, time period, and day type.</p> <p>For each new measurement <math>X_a</math> (congestion intensity), the system computes a Z-score:</p> $Z\_score = \frac{X_a - \mu}{\sigma}$ <p>Where:  <math>X_a</math> = current measured value  <math>\mu</math> = historical mean  <math>\sigma</math> = historical standard deviation</p> <p>This expresses how far the current measurement deviates from typical historical behavior, in units of standard deviations.</p> <p>An anomaly shall be flagged when:</p> $Z\_score \geq Z_{threshold}$ <p>The Z-score threshold is user-defined. Default: 1.5  (Meaning: the current value exceeds the historical mean by more than 1.5 standard deviations.)</p> <p>Single anomalies may occur due to noise; therefore, the system shall look for sequences of consecutive anomalous events. The number of consecutive anomalies will be defined by the user (default=3).</p> <p>When such a sequence is detected, the system classifies the condition as a congestion anomaly.</p>		
6	Pedestrian red light time interval	<p>The metric identifies cases where the pedestrian red signal for a specific pedestrian movement at a junction remains red for longer than a defined threshold over several consecutive signal cycles.</p> <p><b>Formula:</b></p> <p>Given an intersection and a pedestrian movement, the system shall search for sequences of consecutive red-signal events that satisfy both:</p> <p>The number of consecutive events in the sequence is at least a minimum count.</p> <p>In each event of the sequence, the actual red duration is greater than or equal to the configured red-time threshold</p> <p>For each such sequence, the system shall calculate the average excess red time over the threshold.</p> <p>For a given intersection and pedestrian movement:</p> <p>REvent(i) – red event index (signal cycle/event index)  <math>A_R(i+j)</math> – actual red duration [seconds] of the pedestrian movement in event i+j  MinREventNum – minimum number of consecutive events in a sequence, defined by the user (default value = 3 consecutive abnormal event)</p>	Each cycle	Intersection - Pedestrian movements

		<p><math>M_R</math> – red-time threshold [seconds] for the pedestrian phase, defined by the user (Default value: 90 seconds)</p> <p>Step 1 - Detecting a sequence of abnormal red events: The system searches for sequences of consecutive red events:</p> $REvent(i + 1), \dots, REvent(i + k), \quad \forall k \geq MinREventNum$ <p>such that for all events in the sequence:</p> $\forall j \in \{1, 2, \dots, k\} : A_R(i + j) \geq M_R$ <p>That is, every event in the sequence has actual red duration at least equal to the threshold <math>M_R</math>, and the sequence includes at least <math>MinREventNum</math> such events.</p> <p>Step 2 – Average excess red time for the sequence: or each sequence that satisfies the above conditions, the average excess red time is computed as:</p> $ExcessRedAvg = \frac{1}{k} \sum_{j=1}^k (A_R(i + j) - M_R)$ <p>Where: k – number of events in the sequence <math>A_R(i+j)</math> – actual red duration in event i+j <math>M_R</math> – red-time threshold</p> <p>This value represents, on average, how many seconds above the threshold the pedestrian red time was, across the consecutive abnormal events.</p>		
--	--	--	--	--

*Table 6 – Performance metrics*

4.6.2.17 The module shall continuously calculate, collect, and store traffic metrics and Level of Service (LOS) values. It shall also generate and update nominal (baseline) values for each metric and LOS. These baseline values serve as reference points to identify significant deviations, anomalies, or exceptions in traffic behavior, supporting real-time alerts and long-term trend analysis.

4.6.2.18 Scope of metric configuration responsibilities

It is not anticipated that the Supplier will define or configure all traffic metrics and Level-of-Service (LOS) parameters for every traffic entity across the metropolitan network. The Supplier shall be responsible for providing a flexible and configurable calculation engine that enables the definition, aggregation, and adjustment of metrics for all hierarchy levels (links, routes, sub-networks).

During the system acceptance tests (FAT, SIAT, and SAT), installation and trial-run periods, the Supplier shall support AHCo’s operators and traffic engineering team in defining and tuning the set of metrics and LOS parameters for selected traffic entities, in order to validate system functionality and ensure operational readiness.

The configuration of additional metrics and expansion of coverage to other traffic entities shall remain under AHCo’s responsibility during subsequent operational phases, with assistance of the Supplier maintenance support center as described in the section 14.17.

4.6.2.19 Additional traffic metrics

4.6.2.19.1 Along with the development of Block 1 additional data sources may be introduced. These new sources will serve two primary purposes: (1) enhancing the accuracy and reliability of the traffic metrics, and (2) enabling the computation of additional metrics, which are detailed in the following sections.

4.6.2.19.2 The following table describes the additional available data sources and their characteristics. The Supplier may assume that minor variations in data quality and retrieval rates may occur, these will be reviewed and finalized by the CDR stage.

Data Source	Parameter	Unit of Measurement	Retrieval Rate
GTFS (static)	Public transportation schedules and network – agencies, stops, routes, trips and stop times.	text	Daily
SIRI -SM	All field included in the ICD SM 2.8 published by the MOT. Main fields include: <ul style="list-style-type: none"> <li>• Time_stamp</li> <li>• ExpectedArrivalTime / ExpectedDepartureTime</li> <li>• ActualArrivalTime / ActualDepartureTime</li> <li>• VehicleRef -vehicle reference</li> <li>• StopPointRef</li> </ul>	ISO 8601 timestamp ISO 8601 timestamp  ISO 8601 timestamp  string/id string/id	Every 10-30 seconds
Video analytics	Average Speed per lane	Km/h	Every 30 seconds
Video analytics	Occupancy per lane	Percentage	Every 30 seconds
Video analytics	Headway per lane	seconds	Every 30 seconds
Video analytics*	Vehicles count per classification	Integer	Every 30 seconds

Table 7 – Additional data sources

4.6.2.19.3 The MUTC Metrics and Level of Service (LOS) Calculation Module shall compute the following additional metrics, as an extension to those defined earlier (see section 4.6.2.16).

#	Traffic metric	Description	Time period for calculation	Traffic entities
1	Velocity	The calculation of velocity shall incorporate correlation and data fusion, as required, using velocity related information obtained from the newly added data sources. This enhanced process shall enable more accurate and robust speed estimation across all relevant traffic entities and shall also extend the velocity calculation logic to include public transport data where available.	2 min	VC link, VC route, PT link, PT route
2	Travel time	The calculation of travel time shall incorporate correlation and data fusion, as required, using travel time-related information obtained from the newly added data sources. This enhanced process shall enable more accurate and robust speed estimation across all relevant traffic entities and shall also extend the travel time calculation logic to include public transport data where available.	2 min	VC link, VC route, PT link, PT route
3	Volume	As defined in Version 1, with the addition of public transportation vehicle counts.	Each signal cycle	VC link, PT link
4	Vehicles throughput	Vehicle Throughput is defined as the total number of vehicles that cross the stop line of a signalized intersection during a user-selected	Per user-defined period	Intersection - Stop line of each lane

		<p>measurement. This metric reflects the effective discharge of traffic from a specific lane or a defined group of lanes. period.</p> <p><b>Formula:</b></p> $Throughput_p^l = \sum_{t \in p} Veh_t^l$ <p>Parameters:</p> <p><math>l</math> – Lane (approach lane to the intersection)</p> <p><math>p</math> – Measurement period selected by the user (default – one signal cycle)</p> <p><math>Veh_t^l</math> – A vehicle in lane <math>l</math> that crosses the stop line at time <math>t</math> during period <math>p</math>.</p> <p>The system shall allow the user to define lane groups (e.g., left-turn, through, right-turn, or any user-defined combination).</p> <p>The throughput for a lane group <math>GR</math> shall be computed as:</p> $Throughput_p^{GR} = \sum_{l \in GR} Throughput_p^l$ <p><math>GR</math> – The group of lanes</p>		
5	PT delays	<p>Public transportation delay is defined as the average deviation, within a user-specified time interval, between the scheduled arrival time and the actual arrival time of public transport vehicles at designated stops. The user may request delay calculations for all vehicle arrivals at a given stop or restrict the calculation to arrivals of a specific lines serving that stop.</p> <p>Formula:</p> <p><math>S_i</math> = scheduled arrival time of vehicle <math>i</math>.</p> <p><math>A_i</math> = actual arrival time of vehicle <math>i</math></p> <p><math>n</math> = number of arrival events within the selected time interval</p> <p><math>\Delta_i = A_i - S_i</math> = individual delay (positive = late, negative = early)</p> <p>Average delay:</p> $Delay_{avg} = \frac{1}{n} \sum_{i=1}^n \Delta_i$	Every 2 minutes	PT stops
6	PT headways	<p>Public transportation headways are defined as the time intervals between consecutive arrivals of public transport vehicles at predefined stops along a traffic link. For each link, the system shall compute the actual headways by measuring the time difference between successive vehicle arrivals and comparing them to the corresponding scheduled headways.</p> <p>Headways may be calculated in two modes:</p> <p>Per-Line Headways: The system computes headways for a specific public transport line by measuring the intervals between consecutive arrivals of vehicles operating on that line at the selected stops.</p> <p>Aggregate Headways for All Lines: the system shall calculate normalized (percentage) deviation for each line separately and then compute an aggregated performance indicator for all lines serving the link.</p> <p>Formula:</p> <p><math>A_i</math> = actual arrival time of vehicle <math>i</math></p> <p><math>A_{i+1}</math> = actual arrival time of the subsequent vehicle on the same line</p>	Each 2 minutes	PT link

		<p><math>H_i^{act} = A_{i+1} - A_i</math> = actual headway</p> <p><math>H_i^{sch}</math> = scheduled headway</p> <p><math>\Delta H_i = H_i^{act} - H_i^{sch}</math> = headway deviation per line.</p> <p>Per-line or aggregate average deviation:</p> $\Delta H_{avg} = \frac{1}{n} \sum_{i=1}^n \Delta H_i$ <p><math>\delta_i</math> = normalized headway deviation (percentage):</p> $\delta_i = \frac{H_i^{act} - H_i^{sch}}{H_i^{sch}} \times 100$ <p>Aggregate deviation for all lines on the link:</p> $\delta_{avg} = \frac{1}{n} \sum_{i=1}^n \delta_i$ <p>Where:</p> <p>n = total number of headway events for all lines serving the link during the selected interval.</p>		
7	Cyclists' red light time interval	<p>The average deviation of red-light time interval from a threshold in a series of consecutive cycles. The threshold and the number of cycles used for calculation are both pre-defined.</p> <p>Formula:</p> <p>Given an intersection and a bicycle signal movement, the system shall identify sequences of consecutive red-light events for the bicycle movement:</p> $RedEvent_{(i+1)}, \dots, RedEvent_{(i+k)}, \forall k \geq MinRedEventNum$ <p>for which the following condition holds:</p> $\forall j \in \{1, 2, \dots, k\} : ActualRed_{(i+j)} \geq MaxRed$ <p>Where:</p> <p>MinRedEventNum - A parameter defining the number of consecutive events at the intersection, configured by the user (Default = 3 consecutive abnormal events)</p> <p>MaxRed - A parameter defining the minimum red duration for the bicycle movement, configured by the user (default = 90 seconds)</p> <p>ActualRed<sub>(i+j)</sub>, <math>j \in \{1, 2, \dots, k\}</math> - The actual red duration of the bicycle movement in the event (i + j)</p> <p>For each event that meets the conditions above, the system shall compute the average excessive red time.</p> $AvgExceptionalRed = \frac{\sum_{j=1}^k (ActualRed_{(i+j)} - MaxRed)}{k}$	Each signal cycle	Intersection

Table 8 – Additional metrics

4.6.2.19.4 If the module is unable to calculate metrics for various traffic entities due to a lack of data or low quantity, the module will indicate the gap in the traffic situation picture.

4.6.3 Traffic Events, anomalies, and exceptions detection

4.6.3.1 Functionality

This module shall perform basic analytics on the collected traffic data to detect anomalies and exceptions in traffic behavior. Detected exceptions shall be reported as alerts to system operators and made available to other modules for further analysis and response handling.

- 4.6.3.1.1 The criteria for anomaly detection shall include:
- Traffic Events reported by Outstation Devices, external traffic management systems, road users, or analytics tools such as video analytics systems.
  - Degradation in traffic metrics or Level of Service (LOS) is identified by comparing real-time values to predefined thresholds or baselines.
- 4.6.3.1.2 The module shall allow the operator to define threshold values for traffic metrics and LOS for each traffic entity individually, or for groups of entities.
- 4.6.3.1.3 The operator may configure multiple threshold levels to represent varying degrees of degradation severity. At a minimum, the system shall support three levels: High, Medium, and Low.
- 4.6.3.1.4 The module shall include intuitive tools that enable the operator to configure thresholds and other user-defined parameters for individual traffic entities or groups of entities, such as along a specific route, within a sub-network, or across a defined geographic area.
- 4.6.3.1.5 To prevent false or transient alerts, the system shall allow the operator to define a delay interval between the detection of degradation and the issuance of a system alert. If the metric returns to acceptable levels during this interval, the system shall suppress the alert.
- 4.6.3.1.6 System alerts shall be presented to the user as either a pop-up notification or a warning icon associated with the relevant traffic entity. Alerts must be manually acknowledged by the operator to be cleared. If a new alert is triggered for an entity with an existing unresolved alert, it shall be appended to the current alert rather than generating a new one. The system shall also support group approval of multiple alerts. The specific alert display and acknowledgment mechanisms will be finalized during the PDR.
- 4.6.4 Decision Support Service module (DSS)
- 4.6.4.1 In scenarios where manual adjustment of Traffic Light Timing Plan is required, the DSS shall recommend timing plans best suited to align with current demand patterns. It shall support configuring which signal phase should be extended and evaluate the operational impact of such adjustments.
- 4.6.4.2 The DSS shall analyze the parameters of each Traffic Light Timing Plan and rank them according to their fit with the user's input request. The system shall enable users to define which green phases to extend and what trade-offs (e.g., delays in other phases) are acceptable.
- 4.6.4.3 The DSS will check every Traffic Light Timing Plan of the Signalized Intersection that exists in the Directory of plans and not only on those that exist in the Traffic Light Controller.
- 4.6.4.4 If the intersection is part of a Green Wave or sub-network, the DSS shall also include in its recommendations the necessary adjustments across all Signalized Intersections in the same Green Wave or sub-network, to maintain coordinated flow.
- 4.6.4.5 The DSS shall compute and present the analysis results within  $\leq 30$  seconds of user request.
- 4.6.4.6 Where predefined rules exist for the activation of Traffic Light Timing Plans, such rules shall take precedence over DSS recommendations and shall be applied in accordance with their configured logic. The DSS shall continue to operate in parallel and shall provide recommendations to the operator, including where relevant an indication that a predefined rule is applicable or should be modified.
- 4.6.4.7 DSS extensions for Signalized traffic control
- 4.6.4.7.1 The DSS shall provide the rationale behind each recommendation.
- 4.6.4.7.2 The DSS shall provide a transparent display of the reasons and factors influencing its recommendation, enabling the user's examination and validation.
- 4.6.4.7.3 The DSS will show the effect of each recommended Traffic Light Timing Plan on the greens of each phase compared to the current timing plan. The user may choose to execute one of the recommended plans.
- 4.6.4.7.4 The user will be able to set the duration of the execution. At the end of the defined time period, each Signalized Intersection will return to the original daily schedule.
- 4.6.4.7.5 For the avoidance of doubt, the Supplier will provide any already implemented decision support modules which are part of the MUTC.
- 4.6.4.7.6 Using the DSS, users will be able to select a route with multiple Signalized Intersections. The users will define whether to decrease the volume of vehicles entering the route or to increase the volume of vehicles exiting the route. The DSS module will analyze the existing Traffic Light Timing Plans directory of each Signalized Intersection and suggest a combined plan of Traffic Light Timing Plan for each Signalized Intersection.

- 4.6.4.7.7 The DSS module shall provide tools to analyze the effect of the proposed plan compared to the existing one.
- 4.6.4.7.8 The user may agree to execute the proposed plan. The user will be able to set the duration of the execution. At the end of the period, each Signalized Intersection will return to the original daily schedule.
- 4.6.4.7.9 The DSS shall retain historical data regarding past recommendations and implemented actions and shall enable users to review such historical information for similar traffic conditions, locations, time periods, or event types.
- 4.6.4.7.10 The DSS recommendations shall, where relevant and feasible, include reference to the outcomes of similar past cases, including indications of previous successful or unsuccessful actions.
- 4.6.4.7.11 The DSS shall provide authorized users with the ability to submit structured feedback on the effectiveness of DSS recommendations and on the results of implemented Traffic Light Timing Plan changes.

#### 4.6.5 Reports module

- 4.6.5.1 The Reports Module shall enable the creation of reports, either automatically based on predefined schedules or manually upon user requests. Reports will typically include information such as Traffic Events, user activities, traffic metrics, and Level of Service (LOS), segmented by traffic entities, traffic-related objects (e.g., Traffic Light Controllers, VMS units), and specific time periods.
- 4.6.5.2 The report structure shall be flexible, allowing users to configure the content, layout, and parameters of each report. The module shall support capabilities to group, filter, and sort data based on:
  - 4.6.5.2.1 Properties of the reported entities
  - 4.6.5.2.2 Time intervals
  - 4.6.5.2.3 Geographic areas or GIS-based locations
- 4.6.5.3 This flexibility will ensure that users can tailor reports to operational, analytical, and planning needs.
- 4.6.5.4 It will be possible to export the reports in standard formats for Office software, including CSV, XLS, and PDF. The reports will include tabular information, graphs, and other visual aids to read and analyze the report.
- 4.6.5.5 The built-in reports will include as a minimum:
  - 4.6.5.5.1 Detector data report -

The MUTC Reports Module shall include built-in operational reports for detector data, including:

- Display of detectors triggering events for detectors connected to Traffic Light Controllers.
- Filtering by detector type, including Pushbuttons, vehicle detectors, and priority detectors.
- Filtering by date and time range.
- Display of malfunctioning detectors and Push Buttons connected to Traffic Light Controllers.

- 4.6.5.5.2 Traffic light controller reports – Traffic light controller reports will include:

The MUTC Reports Module shall include built-in operational reports for Traffic Light Controllers, including:

- Weekly schedule of a Signalized Intersection.
- Log of operation modes of Signalized Intersections, including start time of each mode, the operation mode, the active Traffic Light Timing Plan, the applicable hierarchy mode, and the entity that issued the instruction, such as username, Signalized Intersection definition, Active Sub-Network definition, Active Configuration definition, or MANTAM definition.
- Planned versus actual executed Traffic Light Timing Plans.

- Green duration report for actual phases.
- Planned maximum green duration versus actual maximum green.
- Values of minimum and maximum parameters for each phase in each Traffic Light Timing Plan, including cycle length and offset (SY)

4.6.5.6 User audit report - documenting user actions in the system such as who manually changed an active timing plan and when, who updated Traffic Timing Light Plan parameters and what were the changes, who downloaded a traffic plan to a Traffic Light Controller, etc.

## 4.7 Traffic operation layer

### 4.7.1 General

The Traffic Operation Layer comprises a set of modules that serve as the front-end applications for managing and executing traffic control and operational processes. These modules provide the primary interface through which operators interact with the system to monitor conditions, manage events, and implement traffic strategies.

### 4.7.2 User display and control module

The user display module shall serve as the primary interface of the MUTC, providing authorized users with access to all required traffic management information, system functions, and operational controls. The user display shall present information primarily through a GIS-based interface and shall support interaction with all the modules of the MUTC, in accordance with the system requirements defined in this SOW.

To reduce implementation risks and enable early operational capability, the user display shall be developed and delivered in incremental versions. In the initial system version (Block 1\version 1), the user display shall be based on the Supplier's existing off-the-shelf (COTS) user interface, as provided within the Supplier's standard traffic management system offering. The Supplier shall ensure that this initial user display fully supports all mandatory functional, operational, and performance requirements specified in this SOW, even if the visual design, layout, or interaction paradigms are based on standard Supplier capabilities.

Subsequent system versions shall include progressive enhancements, adaptations, or extensions to the user display, as required to fully comply with all requirements specified in this section, in accordance with AHCo's priorities, operational feedback, and the approved system roadmap.

The Supplier shall present the proposed UI/UX architecture, including underlying technologies, configuration options, extensibility mechanisms, and development tools, as part of the MUTC system architecture presentation during the quality evaluation interview (see Part 1, Item 9 of Volume D).

The specific scope and implementation approach of the user display for version 1, as well as the proposed roadmap for later versions UI/UX evolution, shall be reviewed and approved by AHCo during the PDR.

#### 4.7.2.1 General requirements

4.7.2.1.1 The display will provide a single sign-on for all MUTC modules.

4.7.2.1.2 All modules shall be accessible to the user immediately after signing in, based on the user's authorization. The display will include icons with links to the relevant modules.

4.7.2.1.3 Users shall have the ability to configure display layouts, and setups for each user according to their tasks and authorization.

4.7.2.1.4 Users will be able to define geographically based areas of interest, such as those for different authorities in the metropolitan area. These areas of interest will be saved in the configuration settings and will be displayed to users, who can then choose the area of interest and visualize all relevant traffic data within that area.

4.7.2.1.5 Users shall have the ability to extract information presented on the display, e.g., show additional information regarding an event, in a dedicated floating window.

4.7.2.1.6 The location of any floating windows shall not interfere with the operation.

- 4.7.2.1.7 The display will maintain visibility of system status by creating an interactive GUI, which will enable the user to visualize all location-based data, including all statuses and alerts, and to activate operations at the specific location without degrading the operators' situation awareness.
- 4.7.2.1.8 The display will offer an unambiguous method of navigating various operations within the system.
- 4.7.2.1.9 The display will prioritize recognition over recall. The cognitive load will be minimized by maintaining task-relevant information within the display.
- 4.7.2.1.10 The display will ensure that the system and the real world are aligned, reflecting the language and concepts that its users would encounter in the real world. Information shall be presented in a logical order, building upon the user's expectations that were established during the task analysis process.
- 4.7.2.1.11 The display will provide immediate feedback on operations and allow for backward movements (undoing and redoing previous actions) whenever feasible.
- 4.7.2.1.12 The display will maintain consistency and standards. Graphic elements and terminology shall be maintained across similar displays. GUI display will have an intuitive, aesthetic, integrated, and consistent look and feel.
- 4.7.2.1.13 The display and workspace shall be designed to accommodate the users' physical (including anthropometry, biomechanics, and physiology) and cognitive capabilities and limitations, taking into account the operational and environmental context in which they operate.
- 4.7.2.1.14 The display will enable users to quickly seek and locate objects, such as traffic entities, by displaying their attributes and enabling pertinent operations on these objects.
- 4.7.2.1.15 The users will have the ability to personalize the interface they are currently using by adding displays to the baseline that was generated by the system administrator and saving it to their UI profile.
- 4.7.2.1.16 The display interface shall support the Hebrew and English languages.
- 4.7.2.1.17 As a default, all displays that are used by the operational personnel in the MANTAM shall be in Hebrew.
- 4.7.2.1.18 Guidelines will be adopted to refer to ISO11064, ANSI/HFS 500, or equivalent standards and guidelines. The Supplier is required to specify the standards that are employed in the system UX design.

#### 4.7.2.2 Main User Interfaces and Displays

The operational concept of the MANTAM is based on the system's ability to establish and maintain traffic situational awareness, which serves as the foundation for all decision-making and traffic control processes. Situational awareness is structured around three levels: perception, understanding, and forecasting. The MUTC user interface shall support these levels as follows:

- 4.7.2.2.1 Provide access to the complete functionality of all MUTC modules.
- 4.7.2.2.2 Support perception and understanding through a map-based "God's View" display of the area managed by the Traffic Situation Picture Display (TSPD) (see Section 4.7.2.3), presenting real-time information such as:
  - Traffic conditions
  - Traffic Events
  - Traffic metrics and LOS
  - Device status (e.g., Outstation Devices)
  - Additional relevant operational data

The Supplier shall describe and demonstrate the user interface displays used to operate the MUTC during the quality evaluation interview (Part 1, Items 1–3 and 5–6 of Volume D), ensuring all required display functionalities as described in the Tender are covered.

#### 4.7.2.3 Traffic Situation Picture Display (TSPD)

- 4.7.2.3.1 The TSPD will be the default display of the operator and shall be presented automatically after signing in to the MUTC.

- 4.7.2.3.2 TSPD is the main user interface of the MUTC - used by most of the users. It is a “god’s view” display of the area managed by the MANTAM, depicting graphically and alfa-numerically the information gathered and calculated by the MUTC modules, such as traffic metrics, LOS, Traffic Events, traffic flow anomalies, warnings, Outstation Devices’ locations and status, rangers’ locations, etc. all in ergonomic ways on an interactive roadway map.
- 4.7.2.3.3 The presentation shall be divided into layers according to the type of the data. The user shall be able to choose the layers to be displayed.
- 4.7.2.3.4 The user shall be able to initiate all traffic management and control operations directly through the TSPD.
- 4.7.2.3.5 The user shall be able to pan, zoom, and center the TSPD.
- 4.7.2.3.6 The user shall be able to measure distances in the TSPD.
- 4.7.2.3.7 TSPD is time dependent – The user shall be able to show past, current, and predicted future traffic situation pictures\*.
- \* Note: This capability is contingent upon the AHCo workload order of traffic prediction capabilities workload.
- 4.7.2.3.8 The TSPD shall enable users to conduct traffic management tasks and processes.
- 4.7.2.3.9 TSPD shall be based on GIS layers and shall include additional geo-located objects that will refer to specific traffic elements such as traffic lights, cameras, VMS, rangers, emergency forces, etc. Elements will be presented with an indication of the serviceability.
- 4.7.2.3.10 All layers and objects in the TSPD will have an attached multi-layered status capability, which will be conveyed to the user in a graphical/alfa-numerical way.
- 4.7.2.3.11 The GIS layers shall obtain all the conventional usability associated with them:
- Displaying items on the map using advanced visuals and keeping to minimal necessary information.
  - Allow to further expand the data displayed on the item.
  - Aggregate data and display the result on the map. For example, showing the total number of Signalized Intersections in each municipality while zooming out.
  - Clustering similar items that are close to each other.
  - Update item information.
  - Creating new items via map.
- 4.7.2.3.12 The TSPD shall allow conducting operations on specific items, such as changing the Traffic Light Timing Plan, media streaming, and more.
- 4.7.2.3.13 The TSPD shall enable the filtering and sorting of items according to attributes related to the item, such as type, geographical area, and time.
- 4.7.2.3.14 The user shall be able to extract information on each layer or object by selecting it in the display.
- 4.7.2.3.15 The TSPD shall enable switching between various locations of interest according to different methods of identifying locations including but not limited to, intersection ID, city name, device ID, and area of interest, sub-network of Signalized Intersection.
- 4.7.2.3.16 The TSPD shall display information about the road attributes including, but not limited to, street names, allowed Movement direction, and lane designation.
- 4.7.2.3.17 The user shall be able to open up to four TSPDs.
- 4.7.2.3.18 The TSPD will include a representation of each green wave group on the map. The user will be able to see visually which Signalized Intersection belongs to each green wave group.
- 4.7.2.3.19 The TSPD will include a representation of each sub-network of the Signalized Intersection on the map. The user will be able to see visually which Signalized Intersection belongs to each sub-network.
- 4.7.2.3.20 Each Signalized Intersection will include a visual indication when it doesn’t work in the weekly signal plan schedule mode. The indication will be unique for each mode of operation.
- 4.7.2.4 Signalized Intersection display
- 4.7.2.4.1 The Signalized Intersection Display shall serve as the main display of the SIM, supporting the management of Signalized Intersections within the MUTC

system. The display shall provide a user-friendly, map-based interface that presents real-time operational status, control options, and configuration tools, enabling authorized users to effectively monitor and manage traffic signal operations.

4.7.2.4.2 The Signalized Intersection Display will also include a tabular based view of the Signalized Intersections allowing users to see summary status and properties of the intersections (The required information to be displayed will be finalized during the CDR phase). The view will support the requirements described in section 4.7.2.6. The Signalized Intersections in the table will be colored and flag by icons according to their status and operation mode.

4.7.2.4.3 Using the Signalized Intersection Display, authorized users shall be able to:

- Create Signalized Intersections
- Modify existing Signalized Intersections
- Remove Signalized Intersections
- Define and update operational parameters and configurations
- Deactivate Signalized Intersections when required

4.7.2.4.4 The Signalized Intersection Display shall:

- Provide a real-time visual representation of the selected intersection and its adjacent roads
- Present inventory data, including name, ID, and location and any properties of the Signalized Intersection.
- Display operational status, including:
  - Active traffic plans
  - Signal lights
  - Phases
  - Detectors
  - Push buttons
- Present traffic metrics and Level of Service (LOS)
- Display Signalized Intersection and the Traffic Light Controller state and data as described in section 4.8.
- Allow to execute commands as described in section 4.8.
- Display maintenance status of all associated devices.

4.7.2.4.5 Display configuration and decision support:

- Allow users to configure and control the layers and objects presented in the display
- Support effective and informed traffic signal management decisions.

4.7.2.5 Dashboards

4.7.2.5.1 The MUTC shall provide a Dashboard module that presents summarized, prioritized, and actionable information to support traffic operations, Traffic Events response, and system maintenance. Dashboard data shall be updated in near real-time (subject to data source update rates). Dashboards shall use visual aids such as KPIs, charts, trends, counters, status tiles, and summary tables.

4.7.2.5.2 The dashboard information architecture, KPIs, thresholds, layout, update behavior, and drill-down paths shall be designed in collaboration with AHCo, reviewed during PDR, and finalized and approved during CDR.

4.7.2.5.3 Each MANTAM site shall support a site-specific dashboard configuration, reflecting local network structure, operational priorities, devices, and zones/corridors. The system shall support a common baseline with site-level customization (e.g., default views, KPIs, thresholds, corridors, device groups).

4.7.2.5.4 The MUTC shall include, at minimum, the following dashboard types for each MANTAM site:

- Traffic operations dashboard: Shall provide an operational overview of current and recent traffic conditions, including at minimum: LOS/traffic metrics by area/corridor, congestion indicators, and key performance trends.
- Traffic Events dashboard: Shall provide visibility of active and recent Traffic Events , including at minimum: sum of Traffic Events with status/severity, impacted links/intersections, and operational actions/response-plan status (where applicable).
- Maintenance and system health dashboard: Shall provide system health and maintainability visibility, including at minimum: device/ Traffic Light Controller/detector communication status, alarms/failures, availability, and data freshness/quality indicators.

The detailed content, widget set, and acceptance criteria for each dashboard type shall be defined and agreed with AHCo during PDR/CDR.

4.7.2.6 Objects Interface

4.7.2.6.1 The MUTC must include object interface for each type of object managed by the users. For example, Links definitions, Route definitions, LOS definitions, detectors definitions where the interface is customized for each type of detector, Traffic Event type and subtype, areas of interest, etc. The following paragraphs indicate some of the main type objects and the required interfaces.

4.7.2.6.2 The system lets users view the attributes of all objects they manage, either individually through a property sheet or in groups via a table display.

4.7.2.6.3 Authorized users will be able to make changes to an object's properties.

4.7.2.6.4 Users can sort objects based on their properties, with the option to sort by multiple properties at once.

4.7.2.6.5 The users will be able to filter the objects by their properties, including multiple selection of values to filter on a single property (example, filter Traffic Incidents with severity critical and high), and combining filters from different properties (example, filter Traffic Incidents of type "accident" and status "open").

4.7.2.6.6 Metrics and LOS definitions interface

The Metrics and LOS Definitions Interface shall allow authorized users to define which traffic metrics are to be calculated for each traffic entity, as well as to configure the threshold values that, when exceeded, will generate exceptions and corresponding system warnings.

The interface shall support the following capabilities:

- Defining the traffic entities, for the calculation of the metrics and LOS.
- Defining the entities which will serve as traffic anchors.
- Defining the metrics to be calculated for each entity. Metrics can be momentary, average (the user shall be able to define the time frame), and deviations from the nominal value.
- Defining thresholds for the calculated metrics and LOS. The threshold will usually be date and time sensitive.
- The system shall allow the user to define two distinct threshold levels for each metric: one for generating a general warning and another for triggering a severe warning. Additionally, the user shall be able to configure a time interval that must elapse after the threshold is exceeded before the warning is initiated, in order to reduce false or transient alerts.

4.7.2.6.7 Traffic Events Interface

The Events and Incidents Interface shall display all Traffic Events detected or reported through various sources, including automated detectors, external traffic management systems, and manual inputs from MUTC users. Each Traffic Events shall be presented along with its associated area of influence, enabling operators to assess its potential impact on traffic conditions and coordinate appropriate response actions.

The Traffic Events interface shall be a time-geo-located container object, following are the basic properties of a Traffic Event:

- Timestamp and duration: this property shall determine the time interval it will be displayed on the TSPD.
- Geo-located: Point or area related; this property shall determine the location it will be displayed on the TSPD.
- Traffic Events properties: The user will be able to specify the attributes that will be displayed on the TSPD by referring to the Traffic Event's attributes list. Clicking on the Traffic Event in the TSPD will prompt the display of all attributes in a distinct table.
- Container-object: Other geo-located objects or simple objects can be attached to the Traffic Event – GIS layers, roads, traffic support teams, traffic lights, Response Plans, etc. – all will be highlighted when the Traffic Event is ongoing and unhighlighted when the Traffic Event is over.
- Users shall have the ability to filter Traffic Events based on their attributes.
- Each type of Traffic Event will be matched with a relevant icon or a relevant representation at the component level (For example as a distinct color).
- The interface will also include tabular views of the Traffic Event with the ability to filter according to their attributes. It will be possible to focus on the area where the Traffic Event occurred on the map from the tabular view. Traffic Events in the table will be colored according to their severity and status.

#### 4.7.2.6.8 Rules planning display

The Rules Planning Display shall provide a dedicated interface primarily for traffic engineers, enabling them to define operational rules for managing Traffic Events and other traffic flow anomalies detected by the MUTC. The rule-definition mechanism shall follow an IFTTT (If This Then That) logic structure, allowing users to specify conditions and corresponding system responses. In addition, the interface shall support the configuration of a sequence of actions to be automatically executed when a defined condition is met, ensuring timely and consistent operational responses to various traffic scenarios.

#### 4.7.2.6.9 Waze link definitions

Users will be able to add, edit, and delete Waze links definitions. The definitions will include:

- The Waze polygon name to which the link belongs.
- Name of the link appeared in Waze.
- Waze code for the link
- MUTC link name
- Signalized Intersections that are part of the link
- Source Signalized Intersection of the link (from)
- Target Signalized Intersection of the link (to)
- Link length
- Allowed speed in the link
- Open road speed (Speed when the road is empty from traffic)
- Travel time in open road (computed by MUTC)
- The links' definitions for Congestion intensity and LOS as described in section 4.6.2.16
- An indication if to show the link on the map. If set to true, the system will show the link LOS on the map.

- State if the link is calibrated. The default is "not calibrated".
- Last date of calibration
- The last username who calibrated the link
- Username who updated the data link
- Last update date

#### 4.7.2.7 Defining special dates

4.7.2.7.1 The system shall allow users to add, update, and remove special dates definitions. The SIM module will use the special dates definitions as described in sections 4.8.5.4, 4.8.7.6.

4.7.2.7.2 The System will allow upload of Israel and Jewish holidays and special dates from external files such as [מאגרי מידע - חגים בישראל - Holidays in Israel - Government Data](#) or compute on which dates they occur.

4.7.2.7.3 In addition, the user may manually define such dates.

#### 4.7.2.8 Defining Holidays and Shabbats times

For each year, the system will store and manage the dates and the start hour and end hour of each holiday and Shabbats of Israel.

4.7.2.8.1 The system shall allow users to add, update, and remove the holidays and weekends dates and hours definitions. The SIM module will use these definitions as described in section 4.8.7.7.

4.7.2.8.2 The System will allow to upload the definitions from external files such as [Government Data](#).

#### 4.7.2.9 Administration interface and displays.

The system administrator shall use the Administration Displays to configure and customize system-level parameters. These displays shall support a wide range of administrative tasks and configurations. The interface shall include, but not be limited to, the following capabilities, which may be organized across one or more dedicated screens:

- Interface control – Controlling the interfaces of the MUTC to external systems and devices. This control includes the ability to close and open interfaces, ability to filter messages based on their type, adjust the data rate, set new interfaces, and monitor the status of the interfaces.
- Users' authorization – Managing the authorization for performing functional operations in the MUTC according to the user's role.
- Database management – Managing the database of the MUTC in aspects of size, date-keeping period, segmentation in the databases, moving data to the archive, etc.
- Configuration management and monitoring – Managing the system configuration aspects regarding cloud services (if applicable), software, and interfaces. Any update in system configuration will be documented using the configuration management display.
- System performance and faults monitoring – Displaying the system's technical performance aspects and system faults. The user shall be able to define specific components or the full system and visualize its real-time and historical performance and faults.

#### 4.7.3 Traffic Events management module

4.7.3.1 The Traffic Events Module is responsible for the comprehensive management of traffic-related planned Traffic Events and Traffic Incidents. It is intended to support the entire lifecycle of Traffic Events—from its initiation, through its ongoing treatment and response, until its final resolution and closure. The module maintains status and progression, ensuring that all operational actions are tracked and documented in real-time.

4.7.3.2 A planned event is characterized by a known start and end date, a name, a description, and one or more associated pre-defined Response Plans. For each Response Plan, users shall be able to configure specific activation and termination times to enable automatic execution. The system shall also allow users to define whether manual confirmation is required before activating or deactivating a Response Plan.

- 4.7.3.3 Traffic Events may be detected internally by the MUTC or reported by external sources, including Outstation Devices, external systems, and road users.
- 4.7.3.4 The Traffic Event management process within the MUTC shall encompass the following key aspects:
- 4.7.3.4.1 Traffic Events may be initiated either manually by users or automatically based on input from the Traffic Events, anomalies and exceptions detection Module.
- 4.7.3.4.2 Traffic lights Response Plans – The module will support Response Plans in several ways: 1) Manually changing traffic light plans of one or more Signalized Intersections in a coordinated manner, typically with the assistance of the DSS module which will recommend the most optimal plan. 2) Applying predefined Response Plans for a single Signalized Intersection or a sub-network of Signalized Intersections manually or automatically as described in Section 4.8.15.
- 4.7.3.4.3 Outstation Devices maintenance events - The module shall include a Root Cause Analysis (RCA) mechanism designed to identify and isolate the primary source of a problem, ensuring that only a single event is reported for the root cause component, rather than generating multiple events for all downstream or affected components. This mechanism shall also handle recurrent failures within abbreviated time intervals, preventing redundant reporting. For example, if communication with a Traffic Light Controller is lost and restored several times within one minute, the system shall aggregate these occurrences and generate only one consolidated communication failure event. This approach improves clarity and reduces alert fatigue for operators.
- 4.7.3.4.4 Traffic Events will have different states; some will be determined automatically by the system and some manually by the user. Some conditions may be applied before moving from one state to another. Example list of states:
- New - new Traffic Events that need to be acknowledged by the user.
  - Acknowledged - user approved of the Traffic Event
  - Rejected - the user checked and found out the event did not happen.
  - Closed - The user finished managing the Traffic Events, and no more changes can be made anymore.
  - Ongoing - the Traffic Event handling is finished but some other issues still need to be resolved.
  - Scheduled - The Traffic Event is scheduled to happen in the future.
- 4.7.3.4.5 Traffic Events will include a validation process in which the user may acknowledge the Traffic Event exists or reject it. For planned Traffic Event, once the due date of activation arrives, the validation process will allow acknowledge, postpone for a user-defined duration, or reject the Traffic Event.
- 4.7.3.4.6 For Traffic Incidents, the activation of a Response Plan will be done manually, and the user may define a period for the termination of the Response Plan. When the termination period arrives, the System will ask the user if to end it. The user will have the option to end it or define a new date of termination.
- 4.7.3.4.7 Reopen closed Traffic Events by administrator - In some cases, specific authorized user groups will be able to reopen closed Traffic Events.
- 4.7.3.4.8 Traffic Events updates and termination – The system shall support continuous updating of Traffic Event status throughout its lifecycle, from initiation to termination. All actions taken concerning the Traffic Event, whether system-generated or user-initiated, shall be logged and reflected in the Traffic Event record. Where applicable, status updates shall be performed automatically based on real-time data received via system interfaces. For example, the system shall automatically update the status of a Traffic Event upon receiving confirmation from a Traffic Light Controller or other connected devices.
- 4.7.3.4.9 Traffic Events storage and retrieval - The system shall support the storage and retrieval of all Traffic Events-related data, including metadata, status updates, associated files, user actions, and linked video or sensor data. Event records shall be archived in a structured and searchable format, allowing authorized users to easily retrieve past events based on parameters such as time, location, Traffic Event type, or severity.
- 4.7.3.5 Traffic Events data
- 4.7.3.5.1 The module shall support the collection, presentation, and ongoing update of metadata related to each Traffic Event. A predefined set of metadata fields shall be used to manage and classify Traffic Events. A preliminary list of required metadata fields is provided in the following table. The final structure will be discussed and finalized during the PDR. The system shall be designed with flexibility to allow system administrators to define additional metadata fields as needed and to assign custom tags (e.g, #police, #military, #accident) to support advanced filtering, categorization, and analytical use in later

stages of Traffic Event review and reporting.

Category	Field
General Data	ID
	Report Date and Time
	Reporter Group (Outstation Device, Emergency agent, etc.)
	Traffic Event Type (Accident, road obstacle, road maintenance, Malfunction, etc.)
	Traffic Event Status (new, approved, rejected, in process, closed, resolved, etc.)
	Traffic Event Description
Location and Time (Multiple for wide area events)	Location (LAT\LONG, road KM)
	Area Type (Road, ramp, bridge, work near road, intersection, etc.)
	Area (Road number)
	Direction
	Start Road Section (Intersection name, interchange name)
	End Road section (Intersection name, interchange name)
	Ramp Type (In, Out)
	From Lane
	To Lane
	Roadblock (yes\no)
	Reported time
	Start Date
	End Date
	Start Hour
End Hour	

*Table 9 - Incident and Event data*

#### 4.7.3.6 Traffic Events management module extensions

- 4.7.3.6.1 To avoid duplication and reduce alert fatigue, the MUTC shall include intelligent filtering mechanisms that consolidate similar or overlapping reports into a single unified Traffic Event entry. These mechanisms will improve operational efficiency by minimizing redundant notifications and ensuring a clear, concise traffic situation picture.
- 4.7.3.6.2 The system shall automatically perform Traffic Events unification based on a set of predefined rules and parameters, such as geographic proximity, event type, time of occurrence, and other relevant attributes. The purpose of unification is to consolidate multiple reports or alerts referring to the same real-world Traffic Event into a single, coherent Traffic Event record, thereby reducing duplication and simplifying operator workload.
- 4.7.3.6.3 The rules governing the unification logic shall be configurable by authorized users and may be updated as needed to improve accuracy.
- 4.7.3.6.4 The user interface shall allow operators to manually indicate which reported events are related and should be merged into one consolidated Traffic Event. During this unification process, the system shall highlight any data discrepancies (e.g., location, time, event type) between the reports and prompt the user to review and resolve these inconsistencies before finalizing the unified Traffic Event record.
- 4.7.3.6.5 Define a suitable Response Plan –The module shall allow users to prepare and manage checklists tailored to distinct types of Traffic Events. Execution of the selected checklist may be performed either manually by the operator or automatically, based on predefined rules and configurations set by authorized users.
- 4.7.3.6.6 Video capture – The system shall support video capture functionality for Traffic Events by enabling operators to record and associate video streams from relevant traffic cameras. Captured video shall be linked to the corresponding event either via a URL reference to the stored video file or through a path to the file’s location within the system’s file storage.
- 4.7.3.6.7 The system shall allow users to link additional files related to a Traffic Event, including but not limited to images, documents, and reports. These files

shall be associated directly with the Traffic Event record and accessible from the Traffic Events interface to support comprehensive documentation, investigation, and reporting.

4.7.3.6.8 Traffic Event handling report – The system shall generate a detailed event handling report capturing the chronological sequence of actions and responses associated with a specific Traffic Event, enabling post-event review and process improvement.

4.7.3.7 CCTV automatically displays

The MUTC shall automatically alert users about Traffic Incidents and as part of the alert break-in with live streaming from a CCTV camera covering the Traffic Incident location if applicable. The live streaming will be displayed on the Video Wall of the MANTAM as described below. For example, when there is an indication that a Traffic Light Controller cabinet door is open, the MUTC shall request to position the CCTV in a preset position covering the cabinet and start displaying the video on the Video Wall.

4.7.3.7.1 For specific types of Traffic Incidents at a Signalized Intersection, the MUTC shall automatically move a CCTV point of view in the intersection to a preset related to the Traffic Incident and start to display the live video on the Video Wall.

4.7.3.7.2 If after a predefined time period, no other Traffic Incident occurs, the MUTC shall stop streaming the live video, and shall enable the CCTV camera to return to its default position – if its position was changed in order to cover the Traffic Incident. The time period for stopping the live streaming will be a configurable parameter.

4.7.3.7.3 When the MUTC stops showing live video streaming, it shall show a blank screen or a clear message that no active alert exists.

4.7.3.7.4 In case of multiple Traffic Incidents in the same period, the MUTC will manage the Traffic Incidents in the FIFO queue – First In First Out.

4.7.3.7.5 The users will be able to define and manage for which types of Traffic Incidents the system will automatically break in with live video streaming covering the Traffic Incident location.

4.7.3.7.6 The interface with the Video Wall will be based on a direct interface with the Video Wall software, which allows the MUTC to define on which location on the Video Wall to show the live video and which CCTV to show or hide. As of the date of publication of the Tender, there is no direct interface to the video wall.

4.7.3.7.7 In case a direct interface with the Video Wall cannot be implemented, a KVM interface will be implemented. This type of interface requires having a dedicated workstation to show live streaming. The KVM is provided by AHCo. The following figure shows the solution.

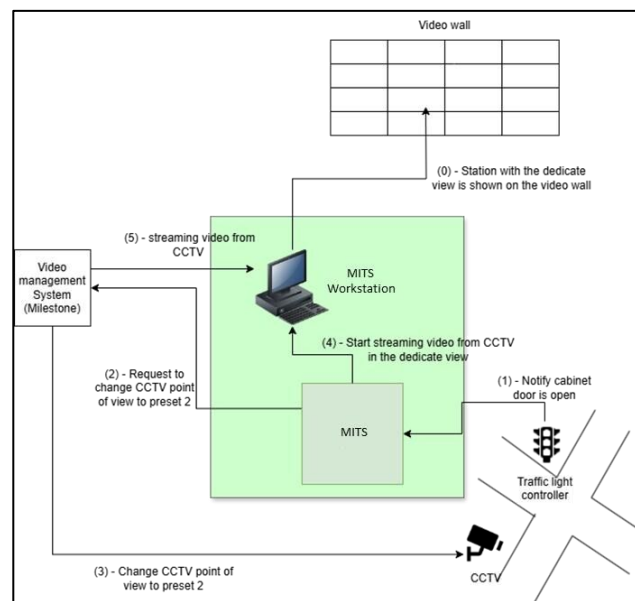

Figure 5 - Conceptual design for breaking in video streaming

In the above figure, a MUTC workstation is always connected to the video wall showing the dedicated view (step 0). If there is no active alarm the dedicated view shows blank or some kind of default home screen. In step 1 the Traffic Light Controller sends a notification to the MUTC. Based on the

type of notification the MUTC will generate a Traffic Incident and decide if to trigger the breaking in video streaming-based alarm. In steps 2 and 3 the MUTC will request to position the CCTV at a specific preset and then in steps 4 and 5, it starts to display live video streaming in the dedicated view on the workstation. As the view is always on the video wall, the video wall will show the live video streaming.

#### 4.7.3.8 Managing road closures

- 4.7.3.8.1 The system shall provide tools to define road closures on links, including location, directions, start date and end date. The road closures properties will include name, creator name, project name, and general description.
- 4.7.3.8.2 Road closures will have state properties like planned (when the start date is in the future), active (when the start date is now or already passed and the end time did not pass), terminated (The end time has passed, or the user manually terminated it).
- 4.7.3.8.3 Users will be able to update the information about the existing road closures.
- 4.7.3.8.4 Users will be able to manually terminate road closure.
- 4.7.3.8.5 If the road closure is active, it will be displayed on the GIS map. If the end date has arrived the system will automatically terminate the road closures.
- 4.7.3.8.6 The creation of a roadblock will be done from the GIS map where the user can select the location of the road closure.
- 4.7.3.8.7 The system will provide a window to manage the list of road closures. The list will support showing planned and active road closures or showing all road closures including terminated road closures.

#### 4.7.4 Management of change requests for traffic management plans

- 4.7.4.1 The MUTC shall allow users to create requests to update traffic management plans.
- 4.7.4.2 Traffic management plans include:
  - 4.7.4.2.1 Traffic light timing Plans
  - 4.7.4.2.2 Pre-defined Response Plans
  - 4.7.4.2.3 Pre-defined rules
  - 4.7.4.2.4 Metrics thresholds
  - 4.7.4.2.5 Policies and strategies
- 4.7.4.3 The request shall have properties that describe the change request, including but not limited to:
  - 4.7.4.3.1 Name of the user who makes the request. MUTC will automatically fill in the value.
  - 4.7.4.3.2 The traffic management plan is to be updated
  - 4.7.4.3.3 The date of the request. MUTC will automatically fill in the value.
  - 4.7.4.3.4 Description of change to be made and why.
  - 4.7.4.3.5 Last update date of the request information. MUTC will automatically fill in the value.
  - 4.7.4.3.6 Last user update of the request information. MUTC will automatically fill in value.
- 4.7.4.4 The request shall have a state that will allow the users to follow the current state
  - 4.7.4.4.1 "New state" which is the default when created.
  - 4.7.4.4.2 "In review"
  - 4.7.4.4.3 "Approved"
  - 4.7.4.4.4 "Implemented"
  - 4.7.4.4.5 "Rejected"

- 4.7.4.5 The MUTC shall notify traffic engineers about new requests.
- 4.7.4.6 Traffic engineer users will be able to change the state of the request and add more information, including a detailed response to the request. Adding new information will be added as a log, so users will see the history of changing.

## **4.8 Signalized Intersection Management (SIM) Module**

This section specifies the capabilities required for the management and control of Signalized Intersections. These capabilities include the configuration and registration of new Signalized Intersections within the system, real-time monitoring of their operational status, and the operation and control of individual Signalized Intersections. In addition, this section defines the operational modes required to manage and coordinate networks of Signalized Intersections across the metropolitan area.

Although this section consolidates all requirements related to the management and control of Signalized Intersections under the SIM module, the implementation of these requirements may be realized through multiple MUTC system modules, including but not limited to the MUTC user interface, data management, and internal databases.

Regardless of the internal allocation of functionality, the Supplier shall ensure that all requirements specified in this section are fully implemented, integrated, and operational as part of the overall MUTC system, with the SIM module serving as the logical and functional focal point for Signalized Intersection management.

Only for convenience purposes, all functionality regarding the Signalized Intersections is described and grouped in a module called Signalized Intersection Management (SIM) as follows. The Supplier will implement each functionality in the different Blocks and Versions as stated in each requirement.

The Supplier may propose an alternative design or process, provided that it fully meets all functional, operational, and performance requirements specified in this section. Any such alternative shall be subject to AHCo's review and explicit approval. In the event that AHCo does not approve the proposed alternative, the Supplier shall be required to design, develop, and deliver the functionality as described in this section, without deviation.

- 4.8.1 All Signalized Intersections in Israel are subject to the Signalized Intersection design guidelines issued by the Ministry of Transport (MOT). These guidelines are published on the MOT official website.

The Supplier may assume that all Signalized Intersections to be connected to the MUTC system have been designed in accordance with these guidelines. Examples of Traffic Signal Timing Plans are provided in the attached documentation:

- 4.8.1.1 Volume E3 - Inbar regular.
- 4.8.1.2 Volume E4 - Lisa regular.
- 4.8.1.3 Volume E5 - Double Signalized Intersection - master.
- 4.8.1.4 Volume E6 - Double Signalized Intersection -secondary.
- 4.8.1.5 Volume E7 - Signalized Intersection with priority for ambulance.
- 4.8.1.6 Volume E8 – Weekend support

- 4.8.2 Traffic Light Timing Plans and detectors plans parameters definitions

AHCo applies multiple standard guidelines and parameter definitions for the design and planning of Traffic Light Timing Plans across the metropolitan area. These parameter definitions specify the required traffic parameters and their meanings, but do not include Traffic Light Controller-specific function declarations or implementation logic used to execute the timing plans.

Each Signalized Intersection is designed in accordance with one selected set of these parameter definitions.

- 4.8.2.1 The SIM shall incorporate, support, and correctly interpret all parameter definitions associated with Traffic Light Timing Plans. The SIM module shall use this understanding to configure, manage, and operate Signalized Intersections in accordance with the functional, operational, interface, and performance requirements applicable to the SIM module, as specified in this Section and throughout the relevant sections of this SOW.

- 4.8.2.2 The SIM shall support multiple Traffic Light Timing Plan parameter definition sets, allowing different Signalized Intersections to be configured and operated according to their respective parameter definitions.
- 4.8.2.3 As of the date of publication of this Tender, the SIM module shall support three (3) distinct Traffic Light Timing Plan parameter definition sets, as used by AHCo for the design and operation of Signalized Intersections:
  - 4.8.2.3.1 Inbar Traffic Light Timing Plan parameters definitions as described in Volume E1 Appendix 2.
  - 4.8.2.3.2 Lisa Traffic Light Timing Plan parameters definitions as described in Volume E1 Appendix 8.
  - 4.8.2.3.3 JNet Traffic Light Timing Plan parameters definitions as described in Volume E1 Appendix 12.
- 4.8.3 Signalized Intersection configuration and lifecycle management
  - 4.8.3.1 The SIM shall allow authorized users to add Signalized Intersections to the SIM, edit their associated information, and remove Signalized Intersections from the SIM.
  - 4.8.3.2 For each Signalized Intersection, the SIM shall allow authorized users to define and maintain a set of attributes, including but not limited to:
    - 4.8.3.2.1 Intersection name.
    - 4.8.3.2.2 Unique AHCo (Ayalon) intersection identifier.
    - 4.8.3.2.3 Traffic Light Controller type.
    - 4.8.3.2.4 Maintenance contractor responsible for the Traffic Light Controller.
    - 4.8.3.2.5 Authority-specific intersection identifier.
    - 4.8.3.2.6 Municipality in which the Signalized Intersection is located.
    - 4.8.3.2.7 Responsible traffic authority name.
    - 4.8.3.2.8 Traffic priority project running through the intersection.
    - 4.8.3.2.9 Free text comments and notes.
  - 4.8.3.3 For each Signalized Intersection, the SIM module shall allow authorized users to define and maintain the required communication parameters for interfacing with the associated Traffic Light Controller, including, at a minimum, the Traffic Light Controller's IP address.
  - 4.8.3.4 For each Signalized Intersection, the SIM module shall allow authorized users to specify the Traffic Light Timing Plan parameter definition set and the detector plan parameter definition set to be used for planning and operating the intersection.
  - 4.8.3.5 The SIM module shall allow authorized users to define and update the geographic location of each Signalized Intersection on the map using GIS coordinates based on the New Israel Grid (Israeli Transverse Mercator).
  - 4.8.3.6 Each Signalized Intersection shall include a graphical intersection diagram representing the traffic signal layout, including traffic light phases, detectors, Push Buttons, and the traffic light bulbs. The intersection diagram shall serve as the primary basis for displaying the real-time and near-real-time status and activity of the traffic signals.
  - 4.8.3.7 The SIM module shall allow authorized users to upload an intersection diagram image (a photo) and to define, configure, and update all associated traffic signal elements, including but not limited to traffic movements, phases, detectors, Push Buttons, and traffic light bulbs.
- 4.8.4 Managing a directory of Traffic Light Timing Plans
  - 4.8.4.1 The SIM module shall manage a directory of Traffic Light Timing Plans and detectors plans for each Signalized Intersection.
  - 4.8.4.2 The SIM module shall allow authorized users to define and maintain a name and intended purpose for each Traffic Light Timing Plan. These attributes shall be stored and managed as properties of the plan.
    - 4.8.4.2.1 The SIM shall allow users to select the purpose of each Traffic Light Timing Plan from a predefined, closed list. The closed list shall be defined and maintained by privileged users, such as traffic engineers or administrators.

- 4.8.4.2.2 The SIM shall allow users to assign multiple purposes to a single Traffic Light Timing Plan.
- 4.8.4.2.3 Example list of purposes:
- Schedule - Peak morning rush, peak afternoon rush, peak evening rush, nighttime, low rush.
- Alternative plans - Morning alternative, afternoon alternative, evening alternative, night alternative, low rush alternative.
- Evacuation plans - Evacuation from south to north, evacuation from north to south, evacuation from east to west, etc.
- 4.8.4.3 The MUTC shall automatically record and maintain metadata for each Traffic Light Timing Plan, including the creation date, last update date, the identity of the user who created the plan, and the identity of the user who last updated the plan.
- 4.8.4.4 As stated in section 4.5.2.4, the number of parameters supported within each Traffic Light Timing Plan depends on the total number of plans configured for the associated Signalized Intersection. In case of sixteen (16) plans, each plan may hold up to two hundred (200) parameters. In case of thirty-two (32) plans, each plan may hold only up to one hundred (100) parameters. These limitations result from the inherent constraints of the Traffic Light Controllers and the applicable Traffic Light Controller interface protocols. The SIM Module should not limit the number of parameters in each plan.
- 4.8.4.5 The SIM module shall allow users to view the parameter values of each Traffic Light Timing Plan.
- 4.8.4.6 The SIM module shall allow users to update the parameter values of Traffic Light Timing Plans.
- 4.8.4.7 The SIM module shall allow users to create new Traffic Light Timing Plans.
- 4.8.4.8 The SIM module shall allow users to create new Traffic Light Timing Plans based on existing plans.
- 4.8.4.9 The SIM module shall allow users to define at least two hundred (200) Traffic Light Timing Plans and detectors plans for each Signalized Intersection.
- 4.8.4.10 For each Traffic Light Timing Plan, the SIM module shall clearly indicate whether the plan is currently stored in the associated Traffic Light Controller.
- 4.8.4.11 For each Traffic Light Timing Plan, the SIM module shall display the date and time of the most recent download to the Traffic Light Controller, the identity of the user who performed the download, and the stated reason for the download (see section 4.8.6.43.2).
- 4.8.4.12 The SIM module shall allow users to search and filter Traffic Light Timing Plans based on their properties, including but not limited to the plan name, purpose, last update date, creating user, and last updating user.
- 4.8.4.13 The SIM module shall support reading and using Traffic Light Timing Plans and detector plans from files generated by the “Inbar” traffic light planning software. The SIM module will add these plans to the directory of the existing plans of the managed Signalized Intersection or will replace them. The Inbar traffic light planning software generates the plans in Microsoft Access file format.
- 4.8.4.14 The SIM module shall support reading and using Traffic Light Timing Plans and detector plans from files generated by the LISA traffic light planning software. The SIM module will add these plans to the directory of the existing plans of the managed Signalized Intersection or replace them. The LISA traffic light planning software supports exporting the plans based on the Unified format as described in Volume E1 Appendix 3 – The Unified format. Additional required data may be needed to be imported from additional files produced by LISA.
- 4.8.4.15 The SIM module shall support reading Traffic Light Timing Plans and detector plans from files generated by the CROSSIG traffic light planning software. The SIM module will add these plans to the directory of the existing plans of the managed Signalized Intersection or replace them. The CROSSIG traffic light planning software supports exporting the plans based on the Unified format as described in Volume E1 Appendix 3 – The Unified format. Additional required data may be needed to be imported from additional files produced by CROSSIG.
- 4.8.4.16 The SIM module shall support reading Traffic Light Timing Plans and detectors plans from files generated by the TRANSEM traffic light planning software. The SIM module will add these plans to the directory of the existing plans of the managed Signalized Intersection or replace them. The TRANSEM traffic light planning software supports exporting the plans based on the Unified format as described in Volume E1 Appendix 3 – The Unified format. Additional required data may be needed to be imported from additional files produced by TRANSEM.
- 4.8.4.17 It shall be the sole responsibility of the Supplier to engage with the manufacturers of the traffic light planning software referenced above and to obtain all information necessary to implement the requirements of this section. AHCo shall bear no responsibility for any changes and compatibility issues between the actual file output of each planning software to the unified format.

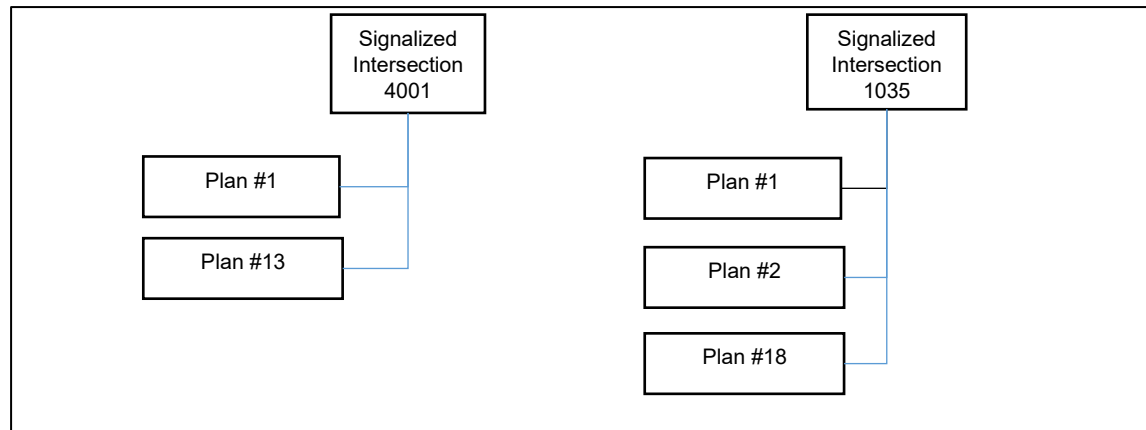

*Figure 6 - relation between Signalized Intersection and Traffic Light Timing Plan*

Figure 5 illustrates two (2) Signalized Intersection. Each one has its own directory of Traffic Light Timing Plans. Signalized Intersection number 1035's directory stores three (3) plans while Signalized Intersection 4001's directory stores only two (2) plans. Plan #1 in each directory is different although the number is the same.

- 4.8.4.18 The SIM will include a tool to generate parameter memory mapping. This mapping will assist the Traffic Light Controller supplier in allocating parameters within the Traffic Light Controller. The SIM module will use this information to identify where each parameter is located in the messages exchanged with the Traffic Light Controller through the communication protocol.
- 4.8.4.18.1 Upon user request, for a selected Signalized Intersection, the SIM will assign a fixed memory location for each parameter used in the Traffic Light Timing Plan, based on its position in the Lexicon. The algorithm will be deterministic, ensuring it consistently generates the same output for identical input.
- 4.8.4.18.2 Users will have the option to export the mapping as a CSV file
- 4.8.4.18.3 Users will have the option to print the mapping as a report.
- 4.8.5 Traffic Light Weekly Schedule Management for a Signalized Intersection

Users shall be able to define for each Signalized Intersection the weekly schedule for executing the Traffic Light Timing Plan:

- 4.8.5.1 The SIM module shall allow users to define multiple operational layouts for a Signalized Intersection. Each operational layout shall represent a distinct configuration for executing Traffic Light Timing Plans and shall include the attributes and elements specified below:
  - 4.8.5.1.1 A name and an intended operational purpose.
  - 4.8.5.1.2 A set of records collectively covering a full twenty-four (24) hour period. Each record shall define a specific time range and the Traffic Light Timing Plan to be executed by the Traffic Light Controller during that period. The defined records shall provide continuous, non-overlapping coverage of the entire twenty-four (24) hour period.
  - 4.8.5.1.3 The selection of the Traffic Light Timing Plan for each time period shall be based on either the plan identifier (number) or the plan purpose. The SIM module shall display both the plan identifier and the associated purpose for the Traffic Light Timing Plan assigned to each period.
  - 4.8.5.1.4 As an alternative to selecting a Traffic Light Timing Plan, the SIM module shall allow users to assign an adaptive operation mode to a defined time period, indicating that the Signalized Intersection shall be managed in adaptive mode during that period.

Operation layout 1		Operation layout 2		Operation layout 3	
Purpose: working days	Traffic Light Timing Plan	Purpose: Friday	Traffic Light Timing Plan	Purpose: Saturday	Traffic Light Timing Plan
00: 00-05: 00	5	00: 00-06: 00	5	00: 00-07: 00	5
05: 00-11: 30	Adaptive	06: 00-12: 00	Adaptive	07: 00-18: 00	4
11: 30-16: 00	4	12: 00-15: 30	22	18: 00-00: 00	22
16: 00-19: 30	22	15: 30-00: 00	8		
19: 30-22: 00	1				
22: 00-00: 00	8				

Figure 7 - Example of 3 Operation layout for a Signalized Intersection

4.8.5.1.5 The SIM module shall allow users to define which Traffic Light Timing Plans are restricted from being selected as alternative Timing Plans by users assigned to the *Operators* permission group while the weekly schedule is active.

4.8.5.2 Defining a weekly schedule for operation layouts

4.8.5.3 For each day of the week (Sunday through Saturday), the SIM module shall allow users to assign the operational layout that the SIM shall execute for the corresponding day.

Day of week	Sunday	Monday	Tuesday	Wednesday	Thursday	Friday	Saturday
Operation layout to execute	1	1	1	1	1	2	3

4.8.5.3.1 On a daily basis, the SIM module shall determine the current day of the week based on the SIM date and shall use the defined weekly schedule to identify and execute the corresponding operational layout.

4.8.5.4 Special dates operation layout

4.8.5.4.1 Based on the SIM-defined special dates (as specified in section 4.7.2.7), the SIM module shall enable to create and manage a dedicated special-dates operational layout for each Signalized Intersection.

4.8.5.4.2 For each Signalized Intersection, the user will select an operation layout for each special date from the existing layouts defined for that specific intersection.

4.8.5.4.3 When a SIM-defined special date occurs, the SIM module shall execute the operational layout assigned to that special date, overriding the standard weekly schedule for the duration of the special date.

4.8.6 Monitoring and controlling a Signalized Intersection

For each Signalized Intersection, the SIM module shall provide all the functionality and tools necessary for monitoring and controlling its operation. The functionality includes but is not limited to:

4.8.6.1 Displaying name, unique ID, location, Traffic Light Controller type, maintenance contractor name, IP address, authority intersection ID, municipality, traffic authority, traffic priority project, and any additional relevant properties related to the intersection and its associated Traffic Light Controller.

4.8.6.2 The SIM module will be able to control a Traffic Light Controller in an independent operating mode. A mode in which the Traffic Light Controller operates according to a schedule stored in the Traffic Light Controller or according to an internal control algorithm implemented within the Traffic Light Controller (for example, an adaptive traffic light algorithm). While the Traffic Light Controller is operating in independent operation mode, the SIM module shall continuously monitor and collect status, health, and operational data from the Traffic Light Controller and from all devices connected to it.

4.8.6.3 The SIM module will also include a remote-control mode of operation. In this mode, the Traffic Light Controller operates according to instructions from the SIM module. For example, the SIM module dictates the weekly schedule or manages the Traffic Light Controller in an adaptive mode. The different remote-control modes are described in the traffic management sections 4.8.11 and 4.8.13.

- 4.8.6.4 The SIM module shall display the current control mode governing the Traffic Light Controller, including, but not limited to, independent operation mode, remote-control scheduled operation mode, and remote-control adaptive operation mode.
- 4.8.6.5 The SIM module shall monitor and display the connectivity status between the MUTC system and the associated Traffic Light Controller.
- 4.8.6.6 Within the Traffic Light Controller monitoring and control interface (The Signalized Intersection display), the SIM module shall indicate whether the Signalized Intersection is part of a coordinated green-wave group and shall display the Traffic Light Controller designated as the master Traffic Light Controller for that group.
- 4.8.6.7 The SIM module shall display a clear and informative indication when a Signalized Intersection is operating in flashing amber/yellow mode.
- 4.8.6.8 The SIM module shall display a clear and informative indication when all traffic light signal bulbs at a Signalized Intersection are turned off.
- 4.8.6.9 The SIM module shall display a clear and informative indication when a cross-green light violation is detected, as well as for any other unsafe or conflicting traffic signal states reported by the Traffic Light Controller.
- 4.8.6.10 The SIM module shall display a clear and informative indication if the Traffic Light Controller operates in a laboratory or test mode.
- 4.8.6.11 The SIM module shall display a clear and informative indication if the traffic light is in manual mode control (For example by traffic police via police panel).
- 4.8.6.12 The SIM module shall monitor, detect, and display clear and informative indications of malfunctions and error conditions reported by the Traffic Light Controller.
- 4.8.6.13 The SIM module shall monitor and display an informative error about Malfunctions of the light bulbs including which bulb is not working.
- 4.8.6.14 The SIM module shall display status indications for each door or panel within the traffic light cabinet, including, at a minimum, the Traffic Light Controller cabinet door, the police control panel door, and the UPS cabinet door, indicating whether each door or panel is open or closed.
- 4.8.6.15 Within the Signalized Intersection display, the SIM module shall present the intersection diagram, including traffic signal phases, Push Buttons, and detectors. The SIM module shall overlay the diagram with near-real-time status indications of each traffic signal bulb, Push Button, and detector, reflecting their current operational states.
- 4.8.6.16 The SIM module will display a cycle graph and green status of the phases, which will be updated in near real-time based on the data received from the Traffic Light Controller.
- 4.8.6.17 The SIM module shall display the ID of the Traffic Light Timing Plan that is running by the Traffic Light Controller.
- 4.8.6.18 The SIM module shall display the identifier number of the Traffic Light Timing Plan that it has requested the Signalized Intersection to execute. If the plan currently active in the Traffic Light Controller does not match the requested plan, the SIM module shall generate an error event and display an appropriate error indication.
- 4.8.6.19 The SIM module shall display the cycle length of the active Traffic Light Timing Plan and the current position within the cycle.
- 4.8.6.20 Over a configurable number of consecutive signal cycles, the SIM module shall analyze whether the total green time of a cycle exceeds the maximum allowed green time defined in the active Traffic Light Timing Plan. If such an exceedance is detected, the SIM module shall generate an error event and display an appropriate error indication. The number of consecutive cycles to be evaluated prior to generating an alert shall be configurable by privileged users.
- 4.8.6.21 Over a configurable number of consecutive signal cycles, the SIM module shall analyze whether the total green time of a cycle is lower than the minimum allowed green time defined in the active Traffic Light Timing Plan. If such a violation is detected, the SIM module shall generate an error event and display an appropriate error indication. The number of consecutive cycles to be evaluated prior to generating an alert shall be configurable by privileged users.
- 4.8.6.22 Over a configurable number of consecutive signal cycles, the SIM module shall analyze whether the green time of any individual traffic signal phase exceeds the maximum allowed green time for that phase, as defined in the active Traffic Light Timing Plan. If such a violation is detected, the SIM module shall generate an error event and display an appropriate error indication. The number of consecutive cycles to be evaluated prior to generating an alert shall be configurable by privileged users.

- 4.8.6.23 Over a configurable number of consecutive signal cycles, the SIM module shall analyze whether the total green time of any individual traffic signal phase is lower than the minimum allowed green time for that phase, as defined in the active Traffic Light Timing Plan. If such a violation is detected, the SIM module shall generate an error event and display an appropriate error indication. The number of consecutive cycles to be evaluated prior to generating an alert shall be configurable by privileged users.
- 4.8.6.24 The SIM module shall display the weekly Traffic Light Timing Plan schedule applied to the Signalized Intersection.
- 4.8.6.25 The SIM module shall allow users to initiate and terminate flashing amber/yellow operation at a Signalized Intersection. Prior to executing such an operation, the SIM module shall require explicit user confirmation.
- 4.8.6.26 The SIM module shall allow users to operate a Traffic Light Controller in "Police" mode.
  - 4.8.6.26.1 Users granted specific special authorization shall be permitted to manually operate the Traffic Light Controller by directly modifying signal patterns. This capability shall allow such users to perform manual control actions from the control center, including, but not limited to, fixing the Traffic Light Controller on a specific phase or manually switching between signal phases.
  - 4.8.6.26.2 Prior to entering manual control mode, the SIM module shall require the user to authenticate and validate their authorization to perform this operation.
  - 4.8.6.26.3 As any action, the SIM module shall log and record all actions performed by users on the Traffic Light Controller, in accordance with the SIM audit and logging requirements.
- 4.8.6.27 The SIM module will allow users to turn off and turn on all the traffic light bulbs at the Signalized Intersection. Before carrying out the operation, it will request confirmation from a user in the manager's group.
- 4.8.6.28 The SIM module shall display a clear indication of whether Illuminated Guidance Traffic Signs associated with the Signalized Intersection are illuminated or not.
- 4.8.6.29 The SIM module shall allow users to turn all Illuminated Guidance Traffic Signs at a Signalized Intersection on or off. Prior to executing this operation, the SIM module shall require explicit user confirmation.
- 4.8.6.30 Based on the Israel daylight hours of each day, the SIM module will automatically turn on and turn off the Illuminated Guidance Traffic Signs. During the daylight hours, the Illuminated Guidance Traffic Signs should be off. This can be accomplished by a calendar of daylight hours which will be uploaded to the SIM module and updated from time to time or an internal calculation by the SIM module.
- 4.8.6.31 The SIM module shall periodically verify that the operational state of the Illuminated Guidance Traffic Signs (on/off) matches the state instructed by the SIM. In the event of a discrepancy, the SIM module shall reissue the required command to the Traffic Light Controller to enforce the instructed state. If the Traffic Light Controller fails to apply the instructed state after a configurable number of retry attempts, the SIM module shall generate an error event and display an appropriate error indication.
- 4.8.6.32 The SIM module shall display the clock value of the Traffic Light Controller as reported by the Traffic Light Controller.
- 4.8.6.33 The SIM module will enable the updating of the Traffic Light Controller clock. This operation shall be supported by a single controller, a selected group of controllers, all controllers of the same model, or all Traffic Light Controllers managed by the SIM.
- 4.8.6.34 Users will be able to set daily automatic scheduled update procedure of the clock in a single, or a selected group, a Sub-Network of Signalized Intersection, a Configuration, or all Traffic Light Controllers. The schedule of the automatic update procedure can be set for a specific hour or multiple recurrent updates like every hour, every half an hour. The SIM will support defining and running different automatic scheduled update schedules to different lists of Traffic Light Controllers.
- 4.8.6.35 The SIM module shall automatically update the Traffic Light Controller clocks in accordance with Daylight-Saving Time changes in Israel. The Supplier shall be responsible for updating the applicable DST change dates within the SIM module during the first quarter of each calendar year.
- 4.8.6.36 The SIM module shall display and store detector data as reported by the Traffic Light Controller, including, but not limited to, detector device status, activation state, traffic counts, speed, and other relevant detection parameters.
- 4.8.6.37 The SIM module shall display and store the Push Buttons data as reported by the Traffic Light Controller (device state, triggering state, etc.).

- 4.8.6.38 The SIM module shall display the triggering state of the detectors and Push Buttons connected to the Traffic Light Controller.
- 4.8.6.39 The SIM module shall monitor and display the state of any detectors connected to the Traffic Light Controller.
- 4.8.6.40 The SIM module shall assess the status (working properly or faulty device) of detectors and Push Buttons based on the data, or absence thereof, provided by the Traffic Light Controller over specified periods. The determined status will then be displayed to the users. Additionally, users will have the capability to customize the duration of these periods for a single Traffic Light Controller, a group of Traffic Light Controllers, or all Traffic Light Controllers collectively.
- 4.8.6.41 The SIM module shall enable force triggering, unforce triggering, and return to normal operation of the detectors and Push Buttons. Signalized Intersections with forced or unforced detectors or Push Buttons will be marked with specific indication.
- 4.8.6.42 The SIM module shall display and store UPS state information as reported by the Traffic Light Controller (UPS mode of operation, battery levels, failure level, etc.).
- 4.8.6.43 The SIM module will support downloading Traffic Light Timing Plans and detectors plans to the Traffic Light Controllers.
- 4.8.6.43.1 The SIM module shall allow users to download a single Traffic Light Timing Plan or a selected group of Traffic Light Timing Plans to the Traffic Light Controller through a single operation.
- 4.8.6.43.2 The SIM module shall support the entry and recording of a user-defined reason for each Traffic Light Timing Plan download operation.
- 4.8.6.43.3 The SIM module shall log every Traffic Light Timing Plan download operation, recording the date and time of the operation, the identity of the user who performed the download, and the stated reason for the download.
- 4.8.6.43.4 Prior to downloading Traffic Light Timing Plans to a Traffic Light Controller, the SIM module shall validate that the plan parameters conform to the Traffic Light Timing Plan parameter definitions used in the design of the corresponding Signalized Intersection. This validation shall include, at a minimum, verification that all required parameters are present, that no undefined or unsupported parameters are included, that parameters are mapped to the correct positions or indices, and that all parameter values fall within their defined allowable ranges. If any validation check fails, the SIM module shall generate a detailed and informative validation report describing the detected issues and shall prevent the plan from being downloaded to the Traffic Light Controller.
- 4.8.6.43.5 Upon user request and following a successful download of a Traffic Light Timing Plan, the SIM module shall verify that the parameters stored in the Traffic Light Controller match the requested plan parameters. The detailed verification procedure shall be defined and finalized during the CDR phase. By default, post-download parameter verification shall be disabled unless explicitly requested by the user.
- 4.8.6.44 The SIM module will allow users to read/upload plans parameters that are stored in the Traffic Light Controller.
- 4.8.6.44.1 The SIM module shall allow users to select a single Traffic Light Timing Plan, a group of plans, or all available plans for retrieval. Upon selection, the SIM module shall request the corresponding plan parameters from the Traffic Light Controller.
- 4.8.6.44.2 The SIM shall present the user with all the plan parameter information received from the Traffic Light Controller in a clear tabular display.
- 4.8.6.44.3 The SIM module shall compare each plan received from the Traffic Light Controller if it exists or not in the SIM Traffic Light Timing Directory. For any plan that does not exist in the SIM directory, the SIM module shall generate an alert and clearly mark such plans as not present in the SIM.
- 4.8.6.44.4 The SIM module shall compare the parameters of each Traffic Light Timing Plan retrieved from the Traffic Light Controller with the corresponding plan parameters stored in the SIM directory. In the event of any incompatibility or mismatch, the SIM module shall generate an alert and present the differing parameters to the user in a clear and intuitive manner.
- 4.8.6.44.5 Based on SIM configuration set by a privileged user. The SIM module shall automatically make a comparison between the Traffic Light Timing Plans stored on the Traffic Light Controller and plans stored in the Traffic Light Timing Directory. This comparison shall be performed following each successful establishment of communication between the SIM and the Traffic Light Controller. The SIM module will generate a report summarizing the results and list any discrepancies and shall send a push notification to the users to inform them of the findings.
- 4.8.6.44.6 Based on SIM configuration set by a privileged user. The SIM shall automatically make a comparison between the Traffic Light Timing Plans stored on the Traffic Light Controller and plans stored in the Traffic Light Timing Directory. This comparison shall be performed periodically as declared the

privileged user for all the Signalized Intersection. The SIM module will generate a report summarizing the results and list any discrepancies and shall send a push notification to the users to inform them of the findings.

4.8.6.45 The SIM module will allow users to download the weekly schedule.

Users may select a single or a group of Signalized Intersections for which to download their weekly schedule defined at the Signalized Intersection level. The SIM will then download to each selected Signalized Intersection the relevant weekly schedule in one operation. If requested by the user, after the downloading process, the SIM will compare the weekly schedule stored in the SIM at the Signalized Intersection level with the information stored in the Signalized Intersection. In case of incompatibility, the SIM module will alert the user of a mismatch in an intuitive way.

4.8.6.46 The SIM module will enable reading/uploading and displaying the weekly signal time plan schedule stored in the Traffic Light Controller.

4.8.6.46.1 Upon a user request, The SIM module will read/upload the weekly schedule stored in the Traffic Light Controller. The SIM shall present the user with all the information received from the Traffic Light Controller in a clear tabular display.

4.8.6.46.2 The SIM module will compare it with the weekly schedule defined in the SIM at the Signalized Intersection level. In case of incompatibility, the SIM module will alert the user of a mismatch in an intuitive way.

4.8.6.46.3 Based on SIM configuration set by a privileged user. The SIM shall automatically make a comparison between the weekly schedule stored on the Traffic Light Controller and the weekly schedule defined in the SIM at the Signalized Intersection level. This comparison shall be performed after any successful connection establishment between the SIM and the Traffic Light Controller. The SIM module will generate a report to summarize the findings and list the discrepancies and send a push notification to the users to inform them of the findings.

4.8.6.46.4 Based on SIM configuration set by a privileged user. The SIM shall automatically make a comparison between the weekly schedule stored on the Traffic Light Controller and the weekly schedule defined in the SIM at the Signalized Intersection level. This comparison shall be performed periodically as declared the privileged user for all the Signalized Intersection. The SIM module will generate a report to summarize the findings and list the discrepancies and send a push notification to the users to inform them of the findings.

4.8.6.47 The SIM module will enable writing/downloading the Israel and Jewish holidays and special dates schedule of the Signalized Intersection to the Traffic Light Controller. If requested by the user, after the downloading process, the SIM will compare the schedule of the Israel and Jewish holidays and special dates defined in the SIM at the Signalized Intersection level with the information stored in the Signalized Intersection. In case of incompatibility, the SIM module will alert the user of a mismatch in an intuitive way.

4.8.6.48 The SIM module will enable reading/uploading and displaying the Israel and Jewish holidays and special dates schedule stored in the Traffic Light Controller.

4.8.6.48.1 Upon a user request, The SIM module will read/upload the Israel and Jewish holidays and special dates schedule stored in the Traffic Light Controller. The SIM shall present the user with all the information received from the Traffic Light Controller in a clear tabular display.

4.8.6.48.2 The SIM module will compare it with the schedule of the Israel and Jewish holidays and special dates stored in the SIM at the Signalized Intersection level. In case of incompatibility, the SIM module will alert the user of a mismatch in an intuitive way.

4.8.6.48.3 Based on SIM configuration set by a privileged user. The SIM shall automatically make a comparison between the Israel and Jewish holidays and special dates stored on the Traffic Light Controller and the special dates defined in the SIM at the Signalized Intersection level. This comparison shall be performed after any successful connection establishment between the SIM and the Traffic Light Controller. The SIM module will generate a report to summarize the findings and list the discrepancies and send a push notification to the users to inform them of the findings.

4.8.6.48.4 Based on SIM configuration set by a privileged user. The SIM shall automatically make a comparison between the Israel and Jewish holidays and special dates stored on the Traffic Light Controller and the special dates stored in the SIM. This comparison shall be performed periodically as declared the privileged user for all the Signalized Intersection. The SIM module will generate a report to summarize the findings and list the discrepancies and send a push notification to the users to inform them of the findings.

4.8.6.49 The SIM module shall retrieve and display the Traffic Light Controller event log/journal, which shall contain at least two hundred (200) records maintained in FIFO order. The SIM module shall interpret and translate operation and error codes contained in the log into clear, meaningful descriptions for user presentation.

- 4.8.6.50 The SIM module will allow users to view and replay historical data of the Signalized Intersection cycles, including green times for each phase, the state of the detectors connected to the Traffic Light Controller, light bulbs state, and Push Buttons states. The exact historical data to be replayed will be finalized during the CDR phase.
- 4.8.6.51 The SIM module shall update all Traffic Light Controller status displays with an end-to-end latency not exceeding two (2) seconds from the time an event occurs at the Traffic Light Controller.
- 4.8.6.52 The SIM module shall enable remote reset of the Traffic Light Controller. Prior to executing the reset operation, the SIM module shall require explicit user confirmation.

#### 4.8.7 Sub-Networks of Signalized Intersections

A Sub-Network is a group of Signalized Intersection that works in coordinated manner. In many cases, a Sub-network consists of Signalized Intersections within a Green Wave (Section 4.8.9 provides detail requirements for Green Wave). In other cases, a Sub-Network may include Signalized Intersections that are not part of a traffic route, but are instead situated distributed across different streets and coordinated for operational or traffic management purposes.

- 4.8.7.1 The SIM module shall allow the creation and management of Sub-Networks of Signalized Intersections.
  - 4.8.7.1.1 Users will be able to add, edit, and remove Sub-Networks configurations comprising Signalized Intersections.
  - 4.8.7.1.2 For each Sub-Network of Signalized Intersections, the user will be able to define a unique name and a descriptive text.
  - 4.8.7.1.3 The SIM module will automatically record and maintain audit metadata for each Sub-Network, including: username who created the Sub-Network, date of creating, date of update, username who update any information of the Sub-Network.
  - 4.8.7.1.4 For each Sub-Network of Signalized Intersections, the user will be able to define which Signalized Intersections are members of it. The SIM will provide a convenient interface for adding and removing traffic lights from the sub-network.

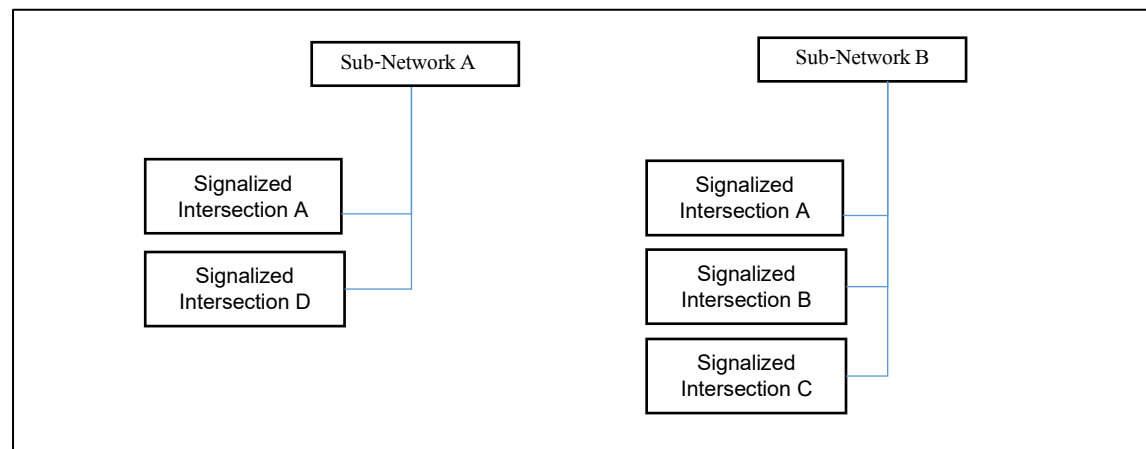

*Figure 8 - Example of Sub-Networks and their Signalized Intersections.*

- 4.8.7.2 Every Signalized Intersection managed by the SIM shall belong to at least one Sub-Network. To support this requirement, the SIM module shall provide a default Sub-Network to which Signalized Intersections may be assigned if no other Sub-Network is specified.
- 4.8.7.3 The GIS map, as part of the MUTC user display, shall include a dedicated layer for the visualization of all active Sub-Networks, with each Sub-Network clearly highlighted. Sub-Networks shall be visually represented by colored polygons encapsulating their member Signalized Intersections. The accompanying figure illustrates an example of Sub-Network visualization within the MUTC display, showing two (2) different SIM configurations. In each configuration, distinct Sub-Networks are presented using different polygon groupings and colors. Further details on Configurations see section 4.8.10.

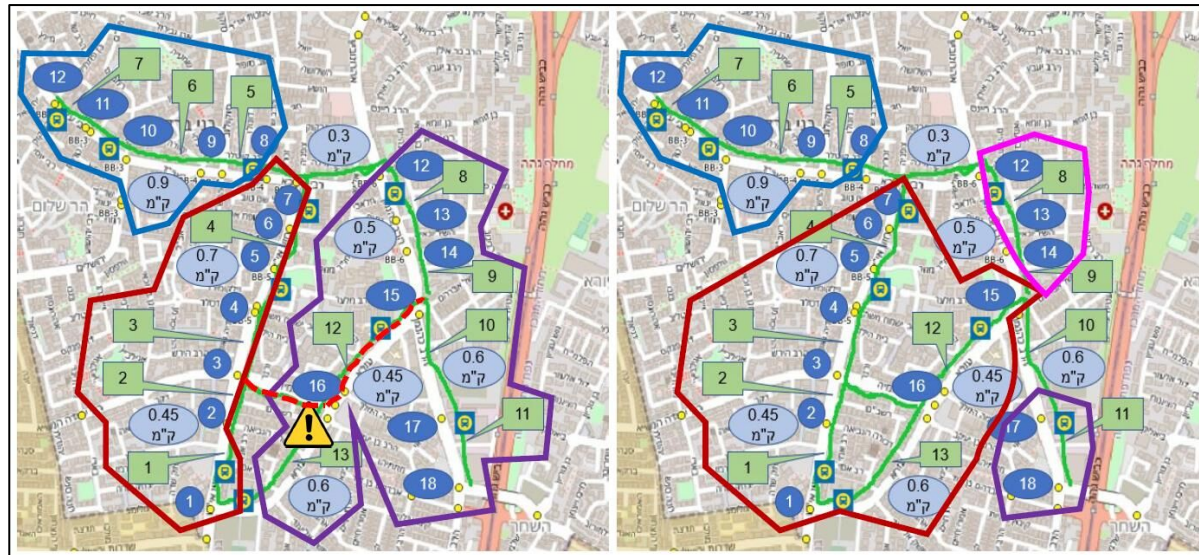

Figure 9 - An example of a map with sub-networks, each surrounded by a colored polygon

#### 4.8.7.4 Coordinated timing plan boards.

The coordinate timing plan boards will allow the users to determine which Traffic Light Timing Plan is executed in parallel at each Signalized Intersection within the same sub-network.

- 4.8.7.4.1 Users shall be able to create, edit, and remove coordinated timing plan boards for each Sub-Network of Signalized Intersection.
- 4.8.7.4.2 The SIM module shall allow users to assign and maintain a name and an intended purpose for each coordinated timing plan board.
- 4.8.7.4.3 For each Signalized Intersection included in a coordinated timing plan board, the SIM module shall allow users to assign the Traffic Light Timing Plan to be executed. For each selectable Traffic Light Timing Plan, the SIM shall display the plan identifier number, cycle length, phase structure, offset, and assigned purpose(s). Users shall be able to select a Traffic Light Timing Plan by either its identifier or its purpose.

ריכוז לוחות לתת רשת																			
בני ברק - רבי עקיבא - בני ברק 3																			
תת רשת: 103																			
תזמון צומת																			
לוח 1																			
לוח 2																			
לוח 3																			
לוח 4																			
לוח 5																			
מסלול	מסלול	מסלול	מסלול	מסלול	מסלול	מסלול	מסלול	מסלול	מסלול	מסלול	מסלול	מסלול	מסלול	מסלול					
היסט	מבנה	תחזור	תכנית	היסט	מבנה	תחזור	תכנית	היסט	מבנה	תחזור	תכנית	היסט	מבנה	תחזור					
0	0	80	5	0	0	120	4	0	0	120	3	0	0	120	2	0	0	110	1
0	0	80	5	0	0	120	4	0	0	120	3	0	0	120	2	0	0	110	6
0	0	80	5	0	0	120	4	0	0	120	3	0	0	120	2	0	0	110	1
0	0	80	5	0	0	120	4	0	0	120	3	0	0	120	2	0	0	110	1

Figure 10 - An example of 5 coordinate timing plan boards for a Sub-Network of Signalized Intersections

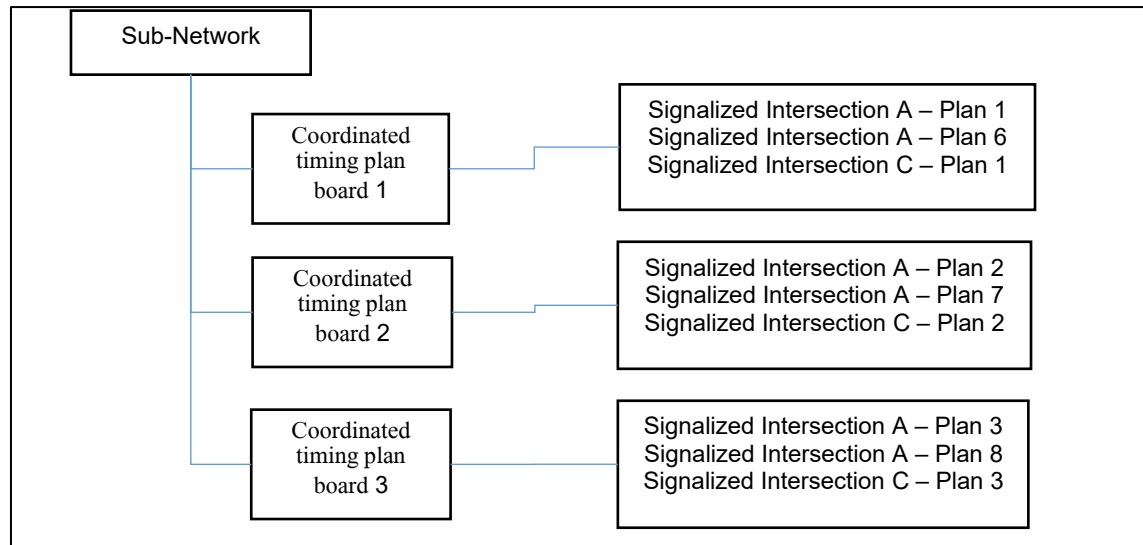

Figure 11 - -network and Coordinated timing plan board relation.

#### 4.8.7.5 Defining a weekly schedule for coordinated timing boards

- 4.8.7.5.1 For each Sub-Network of Signalized Intersections and for each day of the week (Sunday through Saturday), the SIM module shall allow users to define a set of records that collectively represent a full twenty-four (24) hour period during which coordinated timing plan boards are applied. Users may also choose not to define any coordinated timing instructions for a given day.
- 4.8.7.5.2 Each record will include a range of hours, and the Traffic coordinated timing board to be executed by the SIM in this period. The total records must cover the twenty-four (24) hours.
- 4.8.7.5.3 The selection of the coordinated timing board will be based on the name of the board. The SIM will show both the name and the purpose of the coordinated timing board associated with the period.
- 4.8.7.5.4 As an alternative to assigning a specific coordinated timing plan board, the SIM module shall allow users to configure a Sub-Network to operate in central adaptive mode for a defined time period. When central adaptive mode is selected, the SIM shall manage all Signalized Intersections within the Sub-Network using adaptive control during the specified period.

Sunday		Monday		Tuesday		Wednesday		Thursday		Friday		Saturday	
	coordinated timing board		coordinated timing board		coordinated timing board		coordinated timing board		coordinated timing board		coordinated timing board		coordinated timing board
00:00-05:00	5	00:00-05:00	5	00:00-05:00	5	00:00-05:00	5	00:00-05:00	5	00:00-06:00	5	00:00-07:00	5
05:00-11:30	Adaptive	05:00-11:30	Adaptive	05:00-11:30	Adaptive	05:00-11:30	Adaptive	05:00-11:30	Adaptive	06:00-12:00	Adaptive	07:00-18:00	4
11:30-16:00	4	11:30-16:00	4	11:30-16:00	4	11:30-16:00	4	11:30-00:00		12:00-15:30	22	18:00-00:00	22
16:00-19:30	22	16:00-19:30	22	16:00-19:30	22	16:00-00:00	22			15:30-00:00	8		
19:30-22:00	1	19:30-22:00	1	19:30-22:00	1								
22:00-00:00	8	22:00-00:00	8	22:00-00:00	8								

Table 10 - Weekly Schedule of a Sub Network coordinated timing boards

- 4.8.7.5.5 Every day the SIM module will find out what the day of the week is according to the date. Then the SIM module shall use the definitions of the weekly schedule for coordinated timing boards to find which coordinate board or "central adaptive mode" to apply on the Signalized Intersection within the Sub-Network. If a coordinate board or "central adaptive mode" is not declared then the SIM module shall use the weekly schedule of each individual Signalized Intersection (section 4.8.5) within the Sub-Network. The weekly schedule for coordinated timing boards of Sub-Network has a priority over the weekly schedule of an individual Signalized Intersection.
- 4.8.7.5.6 The user shall be able to define list of coordinate boards which are not allowed to be used as alternative coordinated boards by the users (Manually change coordinated boards) and by the SIM (For example, by the central adaptive model).

4.8.7.6 Special dates schedule for coordinated timing boards.

4.8.7.6.1 Based on the SIM special dates (section 4.7.2.7), the SIM module shall create a special dates schedule for coordinated timing boards for each Sub-network.

4.8.7.6.2 For each special date, the user will set records to represent twenty-four (24) hours of coordinated timing boards the SIM will apply. Users may choose not to set any instructions.

4.8.7.6.3 Each record will include a range of hours, and the Traffic coordinated timing board to execute by the SIM in this period. The total records must cover the twenty-four (24) hours.

4.8.7.6.4 Upon occurrence of a defined special date, the SIM module shall execute the schedule configured for that special date at the Sub-Network level, overriding the weekly schedule for coordinated timing plan boards and any other schedule instructions defined for individual Signalized Intersections within the Sub-Network. If no special-date schedule is defined at the Sub-Network level, the SIM module shall apply the special-date schedule defined for each individual Signalized Intersection.

4.8.7.7 Holidays and Shabbat template

For certain municipalities, Signalized Intersections under their jurisdiction are required to be turned off during Shabbat and Jewish holidays, and to be turned back on at their conclusion. This operational process includes a defined sequence of actions, which may include operating the traffic lights in flashing amber/yellow mode for a specified period prior to turning the signals off and prior to restoring normal operation at the end of the Shabbat or holiday.

4.8.7.7.1 The Sub-Network of Signalized Intersection shall support defining a template for Jewish Holidays and Shabbats.

4.8.7.7.2 Within the template, the SIM module shall allow users to define which Traffic Light Timing Plans are to be executed before, during, and after Jewish holidays and Shabbat. For each assigned plan, users shall specify a duration, in minutes, relative to the start or end time of the Jewish holiday or Shabbat.

4.8.7.7.3 Jewish Dates, start times, and end times for Jewish holidays and Shabbat shall be stored and maintained in the SIM, as specified in Section 4.7.2.8. The SIM shall track these dates and determine when they occur. Upon occurrence of a Jewish holiday or Shabbat, and for Sub-Networks to which a Jewish Holidays/Shabbat template is assigned, the SIM module shall apply the instructions defined in the template to each Signalized Intersection within the Sub-Network, in accordance with the start and end times of the specific Jewish holiday or Shabbat. Upon completion of the template-defined operations, the SIM module shall resume execution of the standard SIM instructions applicable to each Signalized Intersection.

Start/End of the Jewish Holidays/Weekend	Minutes	Traffic Light Timing Plan
Start	-15	99 (blinking amber/yellow)
Start	0	98 (Turn off Traffic Light)
End	+15	99 (blinking amber/yellow)

*Table 11 - Example of a template for a Sub-Network of Signalized Intersection*

The example describes a template that instructs the SIM module to do the following on each any Signalized Intersection within the Sub-Network

- Blink for fifteen (15) minutes before the Jewish Holidays and Weekends starts.
- Turn off the lights of the Intersection when the Jewish Holidays and Weekends start.
- Until the end of the Jewish Holidays and Weekends the Signalized Intersection lights are off.
- Blink for fifteen (15) minutes after the end/exit of the Jewish Holidays and Weekends.
- Continue with the SIM regular schedules/instructions.

4.8.7.7.4 A Shabbat and a Jewish Holiday might occur one after the other continuously. In these cases, the SIM must "merge" the templates. Skipping any action that might cause the Signalized Intersection to turn on until the exit/end of the last Jewish Holiday/ Shabbat.

- 4.8.7.7.5 The SIM module shall allow users to create Jewish Holidays/Shabbat templates only for Sub-Networks for which such templates are required.
- 4.8.7.7.6 The SIM module shall provide a dedicated user interface for creating, viewing, and managing templates associated with Sub-Networks.
- 4.8.7.8 Each Sub-Network shall have an operational status indicating whether it is active or inactive.
- 4.8.7.8.1 A Signalized Intersection shall not belong to more than one active Sub-Network at the same time. The SIM module shall enforce this constraint and prevent configuration changes that violate this rule. .
- 4.8.7.8.2 Activation and deactivation of a Sub-Network shall be performed through the SIM Configuration mechanism. See section 4.8.10.
- 4.8.7.9 User operations
  - 4.8.7.9.1 Users may manually select and apply a coordinated board to a Sub-Network. The coordinated timing plan boards available for manual selection shall be limited to those defined as allowable alternatives in the weekly schedule for coordinated timing plan boards.
- 4.8.8 Double Signalized Intersections
 

Double Signalized Intersections are a group of intersections, each with traffic lights that are operated by a single Traffic Light Controller. Groups will mostly consist of two (2) or three (3) Signalized Intersections.

  - 4.8.8.1 The SIM module shall support the definition, representation, and operational control of Double Signalized Intersections.
  - 4.8.8.2 Each constituent Signalized Intersection within a Double Signalized Intersection shall be logically defined and managed as a separate Signalized Intersection entity within the SIM.
  - 4.8.8.3 The same attributes and properties used to describe and define a Signalized Intersection in the SIM shall also apply to each logical Signalized Intersection within a Double Signalized Intersection, including the assignment of a unique AHCo (Ayalon) intersection identifier. Within a Double Signalized Intersection, the logical Signalized Intersection with the highest AHCo (Ayalon) unique identifier shall be designated as the master, while all other logical Signalized Intersections shall be designated as secondary intersections.
  - 4.8.8.4 Traffic engineers may design each Signalized Intersection within a Double Signalized Intersection independently, including separate traffic light operation logic and Traffic Light Timing Plans. However, such designs shall comply with the rules specified below, and the SIM module shall enforce and support these rules.
    - 4.8.8.4.1 Each Signalized Intersection within a Double Signalized Intersection must have the same Traffic Light Timing Plans identifier numbers.
    - 4.8.8.4.2 All Traffic Light Timing plans with same number must have the same cycle length and belong to the same structure\*.
      - \* The set of signal phases and movements, their sequence and inter-relations, and the rules governing their execution within a signal cycle.
    - 4.8.8.4.3 Each Signalized Intersection within a Double Signalized Intersection must have the same weekly schedule.
    - 4.8.8.4.4 Any change to the active Traffic Light Timing Plan for a Double Signalized Intersection shall be applied simultaneously to all constituent Signalized Intersections. The active Traffic Light Timing Plan must be identical across all the Signalized Intersection within a Double Signalized Intersection. To do so, the SIM module will request the Traffic Light Controller operating the Double Signalized Intersection to set a Traffic Light Timing Plan. Then the Traffic Light Controller will apply it internally to each logical Signalized Intersection.
    - 4.8.8.4.5 Although the use of the same Traffic Light Timing Plans numbers, each logic Signalized Intersection shall have a sperate set of parameters. Which means different parameters with different values. The SIM module shall allow to manage a different directory of Traffic Light Timing Plans for each logical Signalized Intersection.
  - 4.8.8.5 The SIM module shall ensure that the weekly schedule for the logic of Signalized Intersections within a Double Signalized Intersection is identical.
  - 4.8.8.6 The SIM module shall review each logic Signalized Intersection's Traffic Light Timing Plans directory in a Double Signalized Intersection to make sure that
    - 4.8.8.6.1 Every logic Signalized Intersection's has the same total number of plans.
    - 4.8.8.6.2 Every plan identification number is defined in each logic Signalized Intersection.

- 4.8.8.6.3 This check will happen after every plan upload from external files or any manual updates to the plans. The check will also include the detectors' plans.
- 4.8.8.7 When uploading Traffic Light Timing Plans for a Double Signalized Intersection, the SIM module shall ensure that each phase identification in one logical Signalized Intersection is different from the phase identifications in the other logical Signalized Intersection within the same Double Signalized Intersection.
- 4.8.8.8 Traffic Light Timing Plans and detector plans for a Double Signalized Intersection shall be downloaded to all constituent logical Signalized Intersections as a single, grouped operation.

#### 4.8.9 Green Waves

A green wave is a group of adjacent Signalized Intersections working in coordination to allow vehicles to pass through the intersections without stopping. A Green Wave may include Signalized Intersections under the jurisdiction of different municipalities and road authorities.

- 4.8.9.1 The SIM module shall allow users to define and manage Green Waves within the SIM, including the ability to create, modify, and remove Green Wave configurations.
- 4.8.9.2 The SIM module shall support configuration of Green Wave attributes, such as name, description, and type, with additional properties to be finalized during the PDR and CDR.
- 4.8.9.3 The SIM will automatically update properties like date of creation, last update date, username created the Green Wave, last username to update the Green Wave definitions.
- 4.8.9.4 For each Green Wave, the users shall be able to define which Signalized Intersections are part of the Green Wave.
- 4.8.9.5 For each Green Wave, the users shall be able to define which Signalized Intersection is the master of the Green Wave.
- 4.8.9.6 For each Green Wave, the SIM module shall allow users to define the synchronization parameters required to ensure correct Green Wave operation across the associated Signalized Intersections. Such parameters shall include, but not be limited to, the Green Wave Offset and the planned progression speed for the Green Wave (expressed in kilometers per hour).
- 4.8.9.7 For each Green Wave, the SIM module shall display if the Green Wave is active.
- 4.8.9.8 For each Green Wave, the SIM module shall display for Each Signalized Intersection within the Green Wave the:
  - 4.8.9.8.1 The active Traffic Light Timing Plan number and purposes.
  - 4.8.9.8.2 Cycle length.
  - 4.8.9.8.3 Current time in the cycle.
  - 4.8.9.8.4 Traffic Light Controller clock.
  - 4.8.9.8.5 Last time the synchronization signal was requested.
  - 4.8.9.8.6 Last time the synchronization signal was received.
- 4.8.9.9 The SIM module shall provide a GIS map layer within the MUTC display that visualizes all active Green Waves.
  - 4.8.9.9.1 Each Green Wave shall be uniquely visualized on the MUTC display map, with its associated Signalized Intersections clearly identified and grouped.
  - 4.8.9.9.2 When a user hovers over a Green Wave on the MUTC display map, the SIM shall display the name of the Green Wave.
  - 4.8.9.9.3 Right click on a Green Wave will allow users to open a data sheet with the properties of the Green Wave.
  - 4.8.9.9.4 The SIM shall display with a special mark Green Waves that are not working in synchronized way.
- 4.8.9.10 The SIM module shall display for each Green Wave a bandwidth diagram. The Green Wave bandwidth diagram is a time–space diagram that graphically represents the continuous time window (bandwidth) during which vehicles traveling at a specified speed can pass through a series of coordinated traffic signals without stopping, by encountering a green indication at each intersection.

- 4.8.9.11 The SIM module shall display a real-time Time-Distance Diagram for each Green Wave. The Diagram will include all the Signalized Intersection within the Green Wave, their active Traffic Timing Plan, and movements.



Figure 12 - An example of Time-Distance Diagram

- 4.8.9.12 Green Waves share operational characteristics similar to Sub-networks. Users shall affiliate a Green Wave to a Sub-network so they can apply the definitions of the Sub-network on the Green Wave. In such a case all the Signalization Intersection within the Green Wave must also be a part of the Same Sub-network.
- 4.8.9.13 The SIM module shall support Green Wave with fixed cycle type.
- In Green Wave with fixed cycle all the Signalized Intersection within a Green Wave, have the same length of cycle.
- 4.8.9.13.1 In most operational scenarios, the SIM module shall not perform real-time coordination between Signalized Intersections participating in a Green Wave. Instead, coordination shall be achieved through independent operation of each Signalized Intersection, for example by using each Traffic Light Controller's internal GPS-based clock to calculate and apply Green Wave Offset synchronization.
- 4.8.9.13.2 In certain Green Wave configurations operating with a fixed cycle, users may instruct the SIM module to actively perform Green Wave Offset synchronization. In such cases, the SIM module shall calculate the required offset for each Signalized Intersection within the Green Wave based on the active Traffic Light Timing Plan and the defined Green Wave parameters and shall transmit synchronization pulses to each Signalized Intersection at the appropriate time to achieve the required coordination.
- 4.8.9.14 The SIM module shall provide tools for the users to analyze the operation of Green Waves. The method to analyze the operation of a green wave is dependent on the type of Green Wave. During the PDR and CDR phase, AHCo will finalize with the Supplier the methods.
- 4.8.9.15 The SIM module will automatically analyze the operation of the Green Wave in real-time. If the Green Wave is not working as expected, the SIM module will raise an alarm, mark it as working without synchronization, and provide full details about the problem. The method to analyze the operation of a green wave is dependent on the type of Green Wave. During the PDR and CDR phase, AHCo will finalize with the Supplier the methods.
- 4.8.9.16 For Green Wave with fixed cycle, the method will include checking:
- 4.8.9.16.1 If the Signalized Intersections' cycle times are not matched.
- 4.8.9.16.2 If the Signalized Intersections are not on the same second of the cycle.
- 4.8.9.16.3 If the Offset parameter value stored in the Signalized Intersections is not equal to the Offset parameter value stored in the SIM.
- 4.8.9.16.4 Based on the Offset value, the SIM checks that the Signalized Intersection is waiting for the synchronization signal pulse (SY) at the right moment in the

cycle, either in relation to the end of the main phase or the SY decision point.

#### 4.8.10 Configurations

A Configuration is a collection of distinct Sub-Networks that do not share any Signalized Intersections and that are grouped together based on a common operational context, such as a shared operating schedule or traffic management policy. Users shall be able to define multiple Configurations to support different operational scenarios, for example applying different traffic policies across regions, managing traffic during special events, or supporting alternative operational modes.

4.8.10.1 The SIM module shall allow users to create, configure, and manage Configurations composed of multiple Sub-Networks of Signalized Intersections.

4.8.10.1.1 Users will be able to add, edit, and remove Configurations.

4.8.10.1.2 For each Configuration, the SIM module shall allow users to define and maintain a unique name and a descriptive text.

4.8.10.1.3 The SIM module shall automatically record and maintain audit metadata for each Configuration, including the identity of the user who created the Configuration, the creation date, the last update date, and the identity of the user who last modified the Configuration.

4.8.10.1.4 For each Configuration, the SIM module shall allow users to define and manage the Sub-Networks of Signalized Intersections that are members of the Configuration. The SIM module shall provide a user-friendly interface for adding Sub-Networks to, and removing them from the Configuration.

4.8.10.1.5 Users shall set a schedule when Configuration is active as explained in section 4.8.10.5. According to the schedule, the SIM module will activate and deactivate Configurations. When a Configuration is active all the Sub-Networks within are also active. Active Configurations means the SIM module will work according to the active Configurations' definitions for Coordinated boards (section 4.8.10.2) and it will ignore the definitions of non-active Configurations.

4.8.10.1.6 Users shall be able to select manually the activation or deactivation of Configurations.

4.8.10.1.7 The SIM module shall monitor Configuration activations and shall prevent the activation of multiple Configurations during overlapping time periods if they include one or more common Signalized Intersections.

4.8.10.2 Coordinated boards for Configuration.

The coordinate boards will allow the users to determine which coordinated timing plan boards will run in parallel with each of Sub-Network within the same Configuration.

4.8.10.2.1 Users may create, edit, and remove coordinated boards for each Configuration.

4.8.10.2.2 Each coordinated board will have a name and a purpose.

4.8.10.2.3 For each Sub-Network within a coordinated board of the Configuration, the user set the Coordinated timing plan of The Sub-Network to execute. The SIM shall show for each Coordinated timing plan the name and purposes.

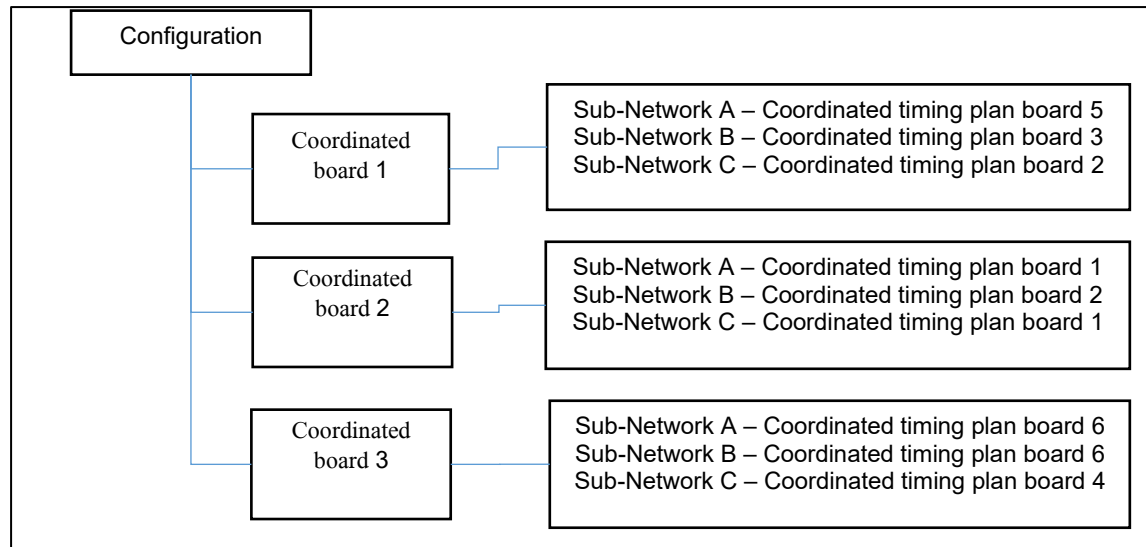

Figure 13 - Configuration and Coordinated boards relation.

#### 4.8.10.3 Defining a weekly schedule for coordinated boards

- 4.8.10.3.1 For each Configuration and for each day of the week (Sunday through Saturday), the SIM module shall allow users to define a set of records that collectively represent a full twenty-four (24) hour period during which coordinated timing plan boards are applied. Users may also choose not to define any coordinated timing instructions for a given day.
- 4.8.10.3.2 Each record shall include a range of hours, and the coordinated board to be executed by the SIM in this period. The total records must cover the twenty-four (24) hours.
- 4.8.10.3.3 The selection of the coordinated board shall be based on the name of the board. The SIM shall show both the name and the purpose of the coordinated board associated with the period.
- 4.8.10.3.4 Users shall be able to select to set the Configuration to work in "Central adaptive mode" instead of specific coordinated board. This mode will indicate the SIM to manage the Signalized Intersections within the Configurations in adaptive mode of operation in the appropriate period.

Sunday		Monday		Tuesday		Wednesday		Thursday		Friday		Saturday	
	coordinated board		coordinated board		coordinated board		coordinated board		coordinated board		coordinated board		Coordinated board
00:00-05:00	1	00:00-05:00	5	00:00-05:00	5	00:00-05:00	5	00:00-05:00	5	00:00-06:00	5	00:00-24:00	1
05:00-11:30	Adaptive	05:00-11:30	2	05:00-11:30	2	05:00-11:30	2	05:00-11:30	Adaptive	06:00-12:00	Adaptive		
11:30-16:00	3	11:30-16:00	4	11:30-16:00	4	11:30-16:00	4	11:30-00:00					
16:00-19:30	5	16:00-19:30	Adaptive	16:00-19:30	Adaptive	16:00-00:00	Adaptive						
19:30-22:00		19:30-22:00		19:30-22:00									
22:00-00:00		22:00-00:00		22:00-00:00									

Table 12 - Weekly Schedule of a Sub Network coordinated timing boards

- 4.8.10.3.5 Every day the SIM module will find out what the day of the week is according to the date. Then, for each active Configuration, the SIM module will use the definitions of the weekly schedule for coordinated timing boards to find which coordinate board or "Central adaptive mode" to apply on the Sub-Networks within the Configuration. If a coordinate board or "Central adaptive mode" are not declared then the SIM module will work upon the weekly schedule for coordinated timing board of the Sub-Networks (section 4.8.7.5) within the Configuration. The weekly schedule for coordinated boards of the Configuration has priority over the weekly schedule of the Sub-Network.

#### 4.8.10.4 Special dates schedule for coordinated boards.

- 4.8.10.4.1 Based on the SIM special dates (section 4.7.2.7), the SIM module shall create a special dates schedule for coordinated boards for each Configuration.

- 4.8.10.4.2 For each special date, the user shall be able to set records to represent twenty-four (24) hours of coordinated boards or "Central adaptive mode" the SIM will apply. Users may be able to choose not to set any instructions.
- 4.8.10.4.3 Each record will include a range of hours, and the coordinated board to be executed by the SIM in this period. The total records must cover the twenty-four (24) hours.
- 4.8.10.4.4 For active Configurations, once the special date occurs, the SIM module shall work upon the schedule set for that date, replacing the weekly schedule for coordinated boards and any other schedule instructions set for each Sub-Network within the Configuration. If no definitions are set for the Configuration, the SIM shall use the Special Dates schedule defined in the Sub-Network entity.
- 4.8.10.5 Scheduling activation of Configurations.
- 4.8.10.5.1 The SIM module shall provide a visual tool (activation scheduler for Configuration) for the user to define when Configurations are active and when not. The tool shall be based on a weekly calendar where user can define every day of the week and every hour which Configurations are active. Configurations that do not appear at a time slot shall not be activated.
- 4.8.10.5.2 The activation scheduler for Configuration tool shall monitor and block the activation at the same period of configurations that share common sub-networks. When user makes such a request, the SIM module shall display an alert while highlighting the conflict. The user must repair the schedule to save it.
- 4.8.10.5.3 The tool will allow users to define for each hour which predefined Response Plans are not allowed to be executed manually. See section 4.8.15.10 for the use of these definitions.
- 4.8.11 Sites
- A Site represents a traffic control center. For each Site, the SIM module shall allow to
- 4.8.11.1 Create, edit, and delete Configurations and their properties.
- 4.8.11.2 Create, edit, and delete Sub-Networks of Signalized Intersections and their properties.
- 4.8.11.3 Create, edit, and delete Signalized Intersections and their properties.
- 4.8.11.4 A Site topology shall consist of a set of Configurations. Each Configuration will consist of Sub-Networks of Signalized Intersections. Each Sub-Network will consist of Signalized Intersections.
- 4.8.11.5 A Signalized Intersections cannot be assigned to different Sub-Network of Signalized Intersections on the same Configuration. Users can assign the same Signalized Intersection to multiple Sub-Networks each belong to a different Configuration. But only one of these Configurations may be active at the same time.
- 4.8.11.6 Configurations will have an active/not active state. When a Configuration is set to active, all its Sub-Networks will also be active. But Configurations must not share the same Signalized Intersection at the same period when active.

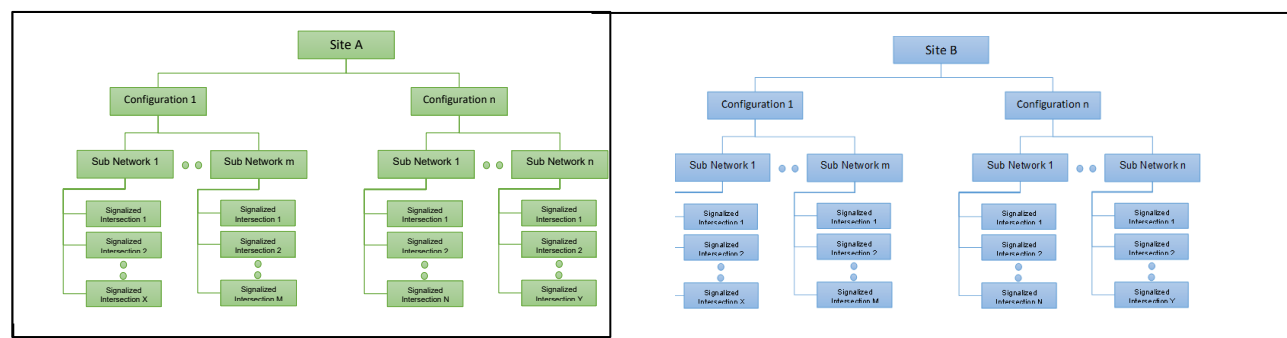

*Figure 14 - Sites topology*

Figure 14 shows two (2) Sites/traffic control centers. Each Site has its own Configurations, Sub-Networks and Signalized Intersections.

#### 4.8.12 Traffic management modes

The SIM module shall support the following modes of traffic management on each Signalized Intersection:

- 4.8.12.1 Setting the Signalized Intersection in an independent operating mode. Independent Signalized Intersections will work according to the weekly schedule stored in the Traffic Light Controller or based on instructions received from an external SIM like an external adaptive management device/SIM. While a Signalized Intersection is in independent operating mode, the SIM module only monitors the operation of the Signalized Intersection.
  - 4.8.12.2 Weekly schedule mode. In this mode of operation, the SIM module applies the weekly signal time plan schedule, overriding the schedule configured in the Traffic Light Controller. The SIM module will apply the schedule to Signalized Intersection as described in section 4.8.13.
  - 4.8.12.3 Central adaptive mode. In the central adaptive mode of operation, the SIM module applies an adaptive algorithm as described in section 4.8.19.
  - 4.8.12.4 A manual choice of an active plan.
    - 4.8.12.4.1 The users shall be able to select a Traffic Light Timing Plan from the plans directory and set the plan as active to a single Signalized Intersection or a group of Signalized Intersections.
    - 4.8.12.4.2 The allowed plans for selection are based on the restrictions that were defined in the current active layout, as described in section 4.8.5.1.5.
    - 4.8.12.4.3 When manually selecting a plan, the SIM module shall use the DSS module for selecting the best-fitting plan as described in 4.6.4.
    - 4.8.12.4.4 If a user selects a Traffic Light Timing Plan that is not in the Traffic Light Controller, the SIM will check if it can be downloaded without replacing an existing plan. If that is not possible, the SIM will prompt the user to choose which Traffic Light Timing Plan to remove. It will then download the required plan, replacing the one the user selected for removal.
    - 4.8.12.4.5 The user may schedule the change to remain in effect until a specified date. Users shall be able to select the action to be performed upon reaching the end date of the scheduled change, including either automatically reverting to the previous mode of operation or generating a notification to the user.
    - 4.8.12.4.6 In case the user does not set a due end-of-change date then the SIM module will automatically return to the previous mode of management according to the next scheduled switch of plan as set in the weekly signal time plan schedule.
  - 4.8.12.5 A manual initiation of blink of amber/yellow blinking mode for a Signalized Intersection.
  - 4.8.12.6 A manual initiation of shutdown to all traffic light bulbs at a Signalized Intersection.
  - 4.8.12.7 A manual activation of predefined Response Plan (section 4.8.15).
  - 4.8.12.8 Automatically initiation of a predefined Response Plan to Signalized Intersection following a rule defined in the Role Based Traffic Light Timing Plan changer (section 4.8.16) or scheduled event (section 4.8.15).
  - 4.8.12.9 Manual Police mode operation – as described in section 4.8.6.26.
  - 4.8.12.10 For each Signalized Intersection, the SIM module shall display an informative indication on the map in which mode the Signalized Intersection is operating.
- 4.8.13 Hierarchy of traffic management modes.

The SIM module should have a hierarchy of execution for its different modes of operation, making it clear which mode to use in any situation. Attached in the following figure is a recommended suggestion of such hierarchy. The number is the hierarchy level, while one (1) is the highest and twelve (12) the lowest. For identical level (numbers) the SIM will apply the last request of mode overriding the previous mode.

Entity level	Manual control		SIM control operations mode				
	Manual operations mode*	Central Adaptive mode	Predefined Response Plans - scheduled via event	Predefined Response Plans – triggered via rules from the Rule Based Traffic Light Timing Plan Changer	Scheduler -Jewish holidays and Shabbat	Scheduler -Special days	Scheduler -Weekly
Signalized Intersection	1	1	4	5		9	12 – The default. Users must define it.
Active Sub-Network of Signalized Intersections	1	1	3	5	6 (The default for Jewish holidays and Shabbat)	8	11
Active Configurations	1	1	2	5		7	10
MANTAM	1	1					

*Table 13 - Traffic management modes*

\* Manual operation mode includes the following – independent operation mode, manual selection of an active plan, a manual operation to blink in amber/yellow, a manual operation to Turn off all the traffic light bulbs a Signalized Intersection, manual Police mode operation, applying manually a predefined Response Plans.

#### 4.8.13.1 Explanation:

4.8.13.1.1 If a user is doing a manual operation, it overrides any other instruction (hierarchy 1).

4.8.13.1.2 If the user requests to manually change the mode of operation to "Central Adaptive mode" it overrides any other instruction (hierarchy 1).

4.8.13.1.3 While a Signalized Intersection is in manual operation mode or "Central Adaptive mode", the SIM will not execute any instructions until the manual operation is finished (hierarchy 1).

4.8.13.1.4 The SIM will execute predefined Response Plans scheduled for event overriding any instructions set through a schedule or by a rule from the Rule Based Traffic Light Timing Plan Changer mode (see restrictions on minimal runtime of rules at section 4.8.16). If an event includes predefined Response Plans which includes instructions for an active Configuration (hierarchy 2), it will override a predefined Response Plans which includes only Sub-Network or Signalized Intersections. If an event includes a predefined Response Plans which includes instructions for an active Sub-Network, but not for an active Configuration (hierarchy 3), it will override a predefined Response Plans which includes only Signalized Intersections.

4.8.13.1.5 Until the predefined Response Plans scheduled event is not ended, the SIM will not apply other SIM instructions.

4.8.13.1.6 The SIM will execute predefined Response Plans triggered via rules from the Rule Based Traffic Light Timing Plan Changer module (hierarchy 5) overriding any schedule instructions. The SIM will use the priority mechanism to decide which rules to apply as described in section 4.8.16.

4.8.13.1.7 If a Signalized Intersection is not working by manual instructions or predefined Response Plans, the SIM will apply schedule instructions. First the SIM will check if current date is a Jewish holiday or Shabbat any apply the schedule set for this kind of date (hierarchy 6). If Jewish holiday or Shabbat schedule is not configured or not occurring at current day, the SIM will check if current date is a special date. If yes, it will apply the schedule set at the highest hierarchy level defined for that Signalized Intersection (hierarchy 7-9). If the current day is not special date or it has no instructions for the special date, the SIM will apply the schedule set at the highest hierarchy level for the weekly schedule (hierarchy 10-12).

4.8.13.1.8 Users will always define weekly schedule for Signalized Intersection at hierarchy 12 and this will be considered the default operation if none other instructions are set.

#### 4.8.14 Apply actions to groups of signalized intersections.

4.8.14.1 Users will be able to apply the actions detailed below on a group of Signalized Intersection in one action.

4.8.14.2 List of actions the user can execute on a group of Signalized Intersections:

4.8.14.2.1 Blinking Yellow/Stop Blinking Yellow.

- 4.8.14.2.2 Turn off /Turn on traffic lights.
- 4.8.14.2.3 Turning off/on Illuminated Guidance Traffic Signs.
- 4.8.14.2.4 Switching between the traffic management mode - independent operating mode.
- 4.8.14.2.5 Switching between the traffic management mode – SIM schedule.
- 4.8.14.2.6 Switching between the traffic management mode – Adaptive operation mode as described in section 4.8.19.
- 4.8.14.2.7 Switching between the traffic management mode – Selecting manually a Traffic Light Timing Plan by its purpose.
- 4.8.14.2.8 Synchronize the Traffic Light Controllers' clock with the SIM clock.
- 4.8.14.3 The SIM shall include users' authorization tools which will grant permission based on the Signalized Intersections' group type and actions type combined with the user's other permissions. For example, traffic operators may change the management modes only to Sub-Networks.
- 4.8.14.4 Before applying group action, the SIM will request for the user approval to execute the action.
- 4.8.14.5 The users will be able to choose the following groups:
  - 4.8.14.5.1 Site – which is all the Signalized Intersection managed by a Site.
  - 4.8.14.5.2 Active Configuration – All the Signalized Intersection belonging to the Configuration.
  - 4.8.14.5.3 An active Sub Network of Signalized Intersection - All the Signalized Intersection belonging to the Sub-Network.
  - 4.8.14.5.4 The user chooses Signalized Intersections manually.
- 4.8.14.6 Users may select a Sub-Network of Signalized Intersection either from the Sub-Network of Signalized Intersections management window or directly from the map.
- 4.8.14.7 When users choose a purpose for a Traffic Light Timing Plan to apply to a group of Signalized Intersections, the SIM module will highlight any intersections in the group that do not already have a plan matching the requested purpose. From this list the users can update any Signalized Intersection's Directory of Traffic Light Timing Plans to include the required purpose.
- 4.8.15 Predefined Response Plans
 

Predefined Response Plans are a set of instructions for conducting plans outside of the schedule for selected Traffic Light Controllers and other Traffic Management Devices to manage or prevent Traffic Incidents.

  - 4.8.15.1 The SIM module shall allow the creation and management of Response Plans. For each Response Plan, the user will associate at least one Traffic Management Device (Signalized Intersection, VMS\*), or a Sub-Network of Signalized Intersections, or a Configuration. The Response Plan may consist of multiple Traffic Management Devices, multiple Sub-Networks, and multiple Configurations.
    - \* If this content has been ordered from the workloads defined in section 9.2.11.
  - 4.8.15.2 The Response Plan will include at least a unique name and a description.
  - 4.8.15.3 The SIM module will automatically fill and update the following fields: username who created the Response Plan, date of creating, date of update, username who update any information of the Response plan.
  - 4.8.15.4 For each Signalized Intersection and Traffic Management Device, in the Response Plan, the user will define what traffic timing plan to run or an action to execute when the SIM runs the Response Plan.
  - 4.8.15.5 The user will be able to set multiple actions on a single Traffic Management Device if the actions do not conflict.
  - 4.8.15.6 For a Signalized Intersection, the SIM module will support the following:
    - 4.8.15.6.1 Change the traffic management modes of the signalized Intersection - Independent operation mode, the SIM module controls the schedule mode, central adaptive mode.

- 4.8.15.6.2 Apply specific Traffic Light Timing Plan.
- 4.8.15.6.3 to start and stop blinking in amber/yellow all Signalized Intersections.
- 4.8.15.6.4 Turn off and turn on all the traffic light bulbs of the Signalized Intersections.
- 4.8.15.6.5 Turn on or off the Traffic Illuminated Guidance Traffic Signs.
- 4.8.15.6.6 Force trigger, stop triggering detectors of the Signalized Intersection.
- 4.8.15.7 For Sub-Networks of Signalized Intersections, the SIM module will support the following:
  - 4.8.15.7.1 Change the traffic management modes of all the signalized Intersection within the Sub-Network – Independent operation mode, the SIM module controls the schedule mode, central adaptive mode.
  - 4.8.15.7.2 Apply specific coordinated timing plan board.
  - 4.8.15.7.3 to start and stop blinking in amber/yellow all Signalized Intersections.
  - 4.8.15.7.4 Turn off and turn on all the traffic light bulbs of the Signalized Intersections.
  - 4.8.15.7.5 Turn on or off the Traffic Illuminated Guidance Traffic Signs.
- 4.8.15.8 For Configurations, the SIM module will support the following:
  - 4.8.15.8.1 Change the traffic management modes of all the signalized Intersection within the Configuration – Independent operation mode, the SIM module controls the schedule mode, central adaptive mode.
  - 4.8.15.8.2 Apply specific coordinate board.
  - 4.8.15.8.3 to start and stop blinking in amber/yellow all Signalized Intersections.
  - 4.8.15.8.4 Turn off and turn on all the traffic light bulbs of the Signalized Intersections.
  - 4.8.15.8.5 Turn on or off the Traffic Illuminated Guidance Traffic Signs.
- 4.8.15.9 For each Response Plan, the user shall be able to define a schedule for activation (one-time and recurring). When the schedule for activation arrives, the SIM module will instruct all the traffic lights that are associated with the Response Plan to execute the plans as defined in the Response Plan. At the end of the defined period, the SIM module shall return the traffic lights to work according to the original mode of management, for example, according to a weekly schedule.
- 4.8.15.10 The user may manually activate a predefined Response Plan in response to an event. The user may set a time to end the execution of the plan. The SIM module will show the users only the allowed predefined Response Plan as defined in the activation scheduler for Configurations at section 4.8.10.5.3. The SIM will check which Response Plans are not allowed according to the scheduler based on the day and hour and will show only the allowed.
- 4.8.15.11 Users may manually stop the execution of predefined Response Plans at any time.
- 4.8.15.12 Predefined Response Plans may also be used by the Automatic Traffic Light Timing Plan Changer module as described in section 4.8.16.
- 4.8.15.13 The SIM module shall show an indication if a predefined Response Plan is currently running.
- 4.8.15.14 Each Response Plan may be edited and deleted.
- 4.8.15.15 Only authorized users may create, edit, or delete a predefined Response Plan.
- 4.8.16 Rule Based Traffic Light Timing Plan Changer module.

The Rule Based Traffic Light Timing Plan Changer module lets you set up rules, and the SIM module keeps checking to see if those rules' conditions are met. When they are, the SIM module runs the instructions from the predefined Response Plan linked to that rule. The rules will be based on monitoring thresholds and values of any metrics and data from devices gathered or computed by the MUTC, such as detector data reported by the Traffic Light Controller, external traffic data systems, congestion measurement, Traffic Incidents, Outstation device state, etc.

- 4.8.16.1 The SIM module will provide a tool to create, edit, and delete a rule, which when the conditions are met, the SIM module will apply a predefined Response Plan.
- 4.8.16.2 Users will be able to set multiple conditions which define a rule including:
  - 4.8.16.2.1 Setting the period for the SIM module to check other conditions involves specifying the days of the week and the hours within each day.
  - 4.8.16.2.2 Defining thresholds for values to different traffic metrics and entities defined in the SIM. For example, specific links have a C LOS or above, the speed of a specific link is equal or less than 20 kmh.
  - 4.8.16.2.3 Defining the existence of malfunctions in Outstation Devices. For example, a specific Signalized Intersection is blinking, or the SIM has no communication with a specific device.
  - 4.8.16.2.4 Defining the existence of Traffic Incidents at specific links or sections. The user is also able to set the location inside the link or section by specifying the range in meters (start and end points). The measurements of the meters are in relation to the start of the road. For example, a Traffic Incident at road 20 between 10,000 meters to 11,000 meters.
  - 4.8.16.2.5 Setting the duration for which conditions must be met before the SIM module confirms them. For instance, a C LOS in a link should be measured for at least 5 minutes. The user will be able to define the duration in minutes (example 5 minutes) or by number of cycles in a Signalized Intersection (example for three (3) cycle of a Signalized Intersections).
- 4.8.16.3 The rule will support defining multiple conditions with "and" and "or" relations.
- 4.8.16.4 Rules will have meta data that the users can edit including name, description.
- 4.8.16.5 Rules will have meta data that the SIM shall automatically fill including date of creation, the name of user created the rule, date of last edit, the name of user that last edited the rule.
- 4.8.16.6 Users should be able to set the number of iterations where all rule conditions are met before triggering the predefined Response Plan. An iteration is counted as one when all conditions are satisfied. Then the SIM will start a new iteration checking the conditions are satisfied from the start of the new iteration.
- 4.8.16.7 Users should be able to set a minimum execution time for the execution of the predefined Response Plan before the SIM makes any other changes.
- 4.8.16.8 Users should have the option to set a maximum execution time for the predefined Response Plan. Once this time limit is reached, the SIM will end the plan and follow the next set of instructions.
- 4.8.16.9 Users shall be able to set a priority level for rules, and the SIM module will apply the highest-level rule when two rules could impact the same Traffic Management Devices or the same area.
- 4.8.16.10 Users shall be able to mark any rule as active or non-active. The SIM will not run non-active rules.
- 4.8.16.11 Users will be able to mark all rules in single selection as active or not active.
- 4.8.16.12 When the SIM executes a rule because the conditions are met, the SIM shall log the rule as the reason for the change of the operation of the Traffic Management Device.
- 4.8.17 Users' permissions regarding the SIM module.
  - 4.8.17.1 The traffic engineers will be authorized to add, edit, and delete the information of the following entities:
    - 4.8.17.1.1 Signalized Intersections, Double Signalized Intersections
    - 4.8.17.1.2 Directories of Traffic Light Timing Plans
    - 4.8.17.1.3 Green Waves
    - 4.8.17.1.4 Sub-Network of Signalized Intersections
    - 4.8.17.1.5 Configurations

#### 4.8.17.1.6 Predefined Response Plans

#### 4.8.17.1.7 Rules for the Rule Based Traffic Light Timing Plan changer module.

4.8.17.2 The traffic operations will be able to view the data and apply actions on the Signalized Intersections using the entities defined by the traffic engineers.

#### 4.8.18 Priority module – Activation type A

AHCo implements different traffic prioritization solutions based on several types of conceptual architecture. This section describes the first conceptual architecture which is called Activation Type A. The second conceptual architecture is called Activation Type B and is described in section 9.2.2.1.

##### 4.8.18.1 Activation Type A is based on the following concept.

4.8.18.1.1 The installation of dedicated priority detectors along routes enables the detection of approaching vehicles. These detectors can range from receivers and transmitters to LPR recognition systems, among other technologies. Upon detecting a designated vehicle, the priority detector sends a signal to the Traffic Light Controllers to adjust the greens, as necessary.

##### 4.8.18.1.2 Designing and implementing Traffic Signal Timing Plans with priority logic.

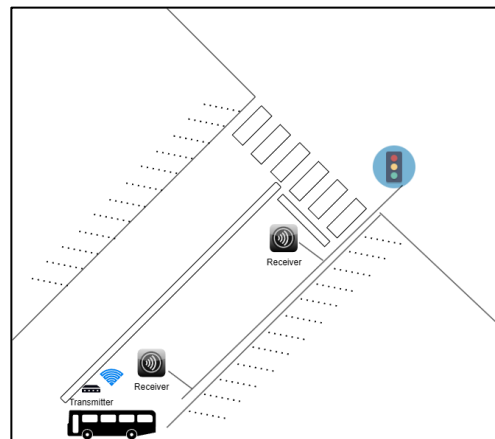

*Figure 15 - Example of Activation Type A traffic priority architecture*

4.8.18.1.3 Activation Type A architecture is an independent solution that enables the priority policy even if the Traffic Light Controllers are not connected to any SIM module.

##### 4.8.18.2 Requirements from the SIM for Activation Type A priority architecture

4.8.18.2.1 To each Signalized Intersection, the SIM should let users assign a property indicating which traffic priority project a Signalized Intersection belongs to.

4.8.18.2.2 The GIS will feature a layer for traffic priority projects, with all Signalized Intersections belonging to the same project outlined identically.

4.8.18.2.3 For each Signalized Intersection with a priority support, the user shall be able to define priority detectors and their properties and show them on the intersection diagram,

4.8.18.2.4 Collecting and storing data from the priority detectors as reported by the Traffic Light Controller. The data may include metadata about the specific vehicle that triggered the detector.

4.8.18.2.5 Like any Signalized Intersection/s detectors, the SIM shall present to the user the state and status of the priority detectors in near real time.

4.8.18.2.6 As part of the Traffic Light Timing Plans directory, the SIM module shall display priority-related parameters from traffic timing plans, enable users to modify their values and download the updated parameters to the Traffic Light Controller.

4.8.18.2.7 The DSS modules will consider priority-related parameters in the decision-making process. The type of parameter definitions for planning the traffic light timing at the Signalized Intersections of a specific priority project will remain the same throughout the route. But it may differ between the priority projects. Example, Metronit project (BRT) is using Inbar Traffic Light Timing Plan parameters definitions while Nofit light rail is using JNet Traffic Light Timing Plan parameters definitions.

- 4.8.18.2.8 Users may be able to enforce and cancel the priority detector state in specific Traffic Light Controllers through the SIM module.
- 4.8.18.2.9 Generate a report to display each phase state alongside the priority detectors state, status and data, and the stop line detector state and status for every change of the phase state or of the priority detectors state. Users will select the Signalized Intersection and range of dates to generate the report.
- 4.8.19 Centralized adaptive traffic management module
- 4.8.19.1 The SIM shall include a centrally adaptive traffic management module. The module will adjust traffic signal timings across a network of intersections continuously in coordinated manner, based on the traffic demand at the intersections and anticipated arrivals from adjacent intersections. It will collect real-time traffic data from detectors and other sensors and use the information as input to the module. The module will adjust cycle length, offsets, splits, and phase sequences dynamically by implementing one or more of the following methods.
- 4.8.19.1.1 Selection of the best plan from existing Traffic Light Timing Plans.
- 4.8.19.1.2 Optimize the plan parameters according to the traffic demand based on changing the parameters of the Timing plan without breaking the plan structure. For example, setting cycle time, green splits, and offset but not changing the phase order.
- 4.8.19.1.3 Any alternative solution approved by the MOT and AHCo such as a fully adaptive traffic management system (which breaks the plan structure). The approval of such a solution is entirely under the responsibility of the Supplier. A signed approval must be submitted to AHCo as a mandatory requirement before the centralized adaptive traffic management Module can be used at the production level.
- 4.8.19.2 If the adaptive traffic management module requires additional field equipment (hereinafter – "**Adaptive Field Equipment**") beyond what already exists at the Signalized Intersection, the Supplier shall design, provide, install, and maintain such devices as specified in Section 7.
- 4.8.19.2.1 The SIM module shall incorporate the Adaptive Field Equipment in the Signalized Intersections display.
- 4.8.19.2.2 The SIM module shall monitor any Adaptive Field Equipment including monitoring the state, status and any alert received for the equipment and add it to the maintenance situation awareness picture.
- 4.8.19.2.3 The SIM module shall monitor the calibration state of any Adaptive Field Equipment that needs calibration process, including managing the state of calibration, date of calibration, and due date of calibration.
- 4.8.19.2.4 Traffic data gathered from Adaptive Field Equipment will be stored in the system database like any traffic detectors connected to the MUTC. The Supplier will implement the requirements that are described in section 9.2.4.6.
- 4.8.19.2.5 As any other source for traffic data, the information from Adaptive Field Equipment will be merged into the data processing and analytics layer as described in section 4.6.
- 4.8.19.3 AHCo will conduct a POC for the centralized adaptive traffic management module in order to evaluate its capabilities, operational suitability, and performance, and to assist the Supplier in the process of obtaining MOT approval for the module and for any Adaptive Field Equipment requiring such approval. The centralized adaptive traffic management module shall initially be supplied and configured for the POC scope, which shall cover up to fifteen (15) Signalized Intersections operated by the centralized adaptive module (hereinafter – "**Adaptive Signalized Intersections**"). Any rollout beyond the approved POC scope shall be subject to successful completion of the POC, achievement of the agreed success metrics, and receipt of the required approval.
- 4.8.19.3.1 During the PDR phase, AHCo will define the POC goals and success metrics. The Supplier shall design the POC, prepare the SIM and the relevant Adaptive Signalized Intersections for the POC, and perform the POC together with AHCo. The POC shall be carried out during MUTC Version 1.
- 4.8.19.3.2 The Supplier will analyze, design, set, and implement all required configurations and definitions in the SIM to manage those Adaptive Signalized Intersections in adaptive mode using the centralized adaptive traffic management module.
- 4.8.19.3.3 Design, procurement, supply, installation, and maintenance of Adaptive Field Equipment for the Adaptive Signalized Intersections.
- 4.8.19.3.4 The adjustment and calibration of the Adaptive Signalized Intersections in the SIM during the POC.
- 4.8.19.3.5 The supplier will create and share reports to help AHCo assess how the centralized Fully Adaptive Management System has affected traffic, comparing it to the period before the POC.
- 4.8.19.3.6 To reduce the complexity of the POC, prioritization of Public Transportation will not be part of the POC.

- 4.8.19.3.7 The Supplier will take into account that the number of Signalized Intersections may vary by up to 20% without any additional payment to the Supplier.
- 4.8.19.3.8 AHCo will choose a sub-network to be managed by the central adaptive management module of Signalized Intersections during the POC until the SRR. Volume E1 Appendix 10 – Candidate sub-networks of Signalized Intersection to participate in the centralized adaptive traffic management POC - describes two possible candidates of such sub-networks.
- 4.8.19.4 The adaptive module shall comply with the latest edition of the applicable MOT guide for planning Signalized Intersections as of the date defined for design approval. Any future changes to such guidelines shall be reviewed through the contractual change-management process, and the Supplier shall implement applicable changes in accordance with approved scope, schedule, and commercial arrangements. The latest edition is published on the MOT website at [link](#).
- 4.8.19.5 If the central adaptive management module (via the SIM module) is connected directly to the Traffic Light Controller without an adaptor device, it shall utilize the communication protocols as detailed in this document. If the existing protocol is missing required messages for adaptive management, the Supplier will design and implement the required changes in the protocol. The payment for adjusting the protocol will be based on the BoQ. In parallel, AHCo will coordinate with each traffic light maintenance contractor the implementation of the required changes at the Traffic Light Controller's side.
- 4.8.19.6 The adaptive module shall support coordination and operation of green waves.
- 4.8.19.7 The adaptive module shall support and management of coordination and operation of Sub-Networks of Signalized Intersections.
- 4.8.19.8 The adaptive module shall support integration with the traffic-prioritization functions defined in this SOW and in the approved detailed design.
- 4.8.19.9 The adaptive module shall be modified to allow traffic engineers to set restrictions on the decision making of the adaptive module. For example, Max length for a cycle cannot be greater the 120 seconds. Unique restrictions may be applied to:
  - 4.8.19.9.1 A single Signalized Intersections
  - 4.8.19.9.2 A Sub-Network of Signalized Intersections.
  - 4.8.19.9.3 All the Signalized Intersections working in this mode.
  - 4.8.19.9.4 The restrictions will be set on road users like pedestrians, bicycle users, public transportation, and vehicles which can be translated to movements, dedicated parameters, and relevant metrics. The user will define minimum or maximum for a parameter or metric and the module will try to adjust the operation of the Signalized Intersection to match the restriction. The user will also define the duration for restriction. The duration can be set in minutes (minimum 15 minutes), hours, days, weeks, months.
  - 4.8.19.9.5 The exact restrictions will be defined in the PDR and CDR phase.
- 4.8.19.10 The adaptive module shall be modified to implement any demand related to fulfilling traffic management policies as described in section 8.4. To align with the desired policy, it will automatically adjust the Adaptive Signalized Intersection to reach the goals of the policy.
 

Note: The implementation of traffic management policies, as described in Section 8.4, is within the scope of Block 2. Accordingly, the adaptive module shall be enhanced in Block 2 to support such policies and to automatically adjust the operation of Adaptive Signalized Intersections in order to align with the objectives of the applicable policy.
- 4.8.19.11 The adaptive module shall monitor the operation of the Signalized Intersections it manages. When a Signalized Intersection does not comply with the guidelines or restrictions, a detailed defect must be generated to alert the users.
- 4.8.19.12 The adaptive module shall be capable of using traffic data received by the MUTC from approved and integrated sources, including detectors connected to Traffic Light Controllers, external traffic-data systems, and external detector systems, subject to interface availability and data-quality suitability for adaptive control.
- 4.8.19.13 Adaptive control strategies shall comply to hierarchy-level policies and override priorities as defined in Section 4.8.13.
- 4.8.19.14 In Volume C – Proposed System Compliance Table & Document (item 11), submitted as part of the proposal, the Supplier shall describe the
  - 4.8.19.14.1 Description of the method of operation of the module, including how it manages a single Signalized Intersection, a green-wave, and a sub-network of intersections.

- 4.8.19.14.2 Explanation of the adaptive algorithm concept.
- 4.8.19.14.3 Capabilities of the adaptive module and any information needed to implement the module.
- 4.8.19.14.4 The detector's layout in a four (4) approaches intersection (cross intersection).
- 4.8.19.14.5 Detailed list of required data from the detectors.
- 4.8.19.14.6 Information about required parameters the Adaptive algorithm needs to have in the Traffic Light Timing Plans.
- 4.8.19.14.7 Details about required messages in the communication protocol between the SIM and the Adaptive Signalized Intersection.
- 4.8.19.14.8 Details about the external devices the supplier must connect to the Traffic Light Controllers to run the adaptive algorithm. This includes the device's technical specifications, communication requirements with the Traffic Light Controller and the MUTC system, electrical requirements, and other related information.
- 4.8.19.15 Adding extra Signalized Intersections, beyond those already supplied during the POC, will be considered a Change Order and paid for separately, as stated in Section 13 of the Agreement.
- 4.8.20 SIM module extensions
  - 4.8.20.1 The SIM module will include a visual tool to adjust and tune the Green-Wave offset parameters in Traffic Light Controllers that are part of the green wave. The user will be able to adjust the starting point of a phase in each Traffic Light Controller and see visually the new green wave's bandwidth. The functionality will be available for any Traffic Light Timing Plans coordinated with a green wave.
  - 4.8.20.2 Monitoring VPS signs connected to the Traffic Light Controller.

In several Signalized Intersections, there are VPS connected to the Traffic Light Controller. The Traffic Light Controller uses these VPS to change the designation of lanes.
  - 4.8.20.2.1 The Supplier shall update the communication protocol drivers with the Traffic Light Controllers to allow receiving and transmitting the information about the VPS. The Supplier will coordinate the changes in each protocol with the Traffic Light Controller suppliers.
  - 4.8.20.2.2 The MUTC shall receive the state of the VPS (the VPS's current message) from the Traffic Light Controller.
  - 4.8.20.2.3 The MUTC shall receive notification if a minor fault occurs in the VPS from the Traffic Light Controller. The MUTC will generate an alert upon receiving minor faults.
  - 4.8.20.2.4 The MUTC shall receive notification if major fault occurs in the VPS from the Traffic Light Controller. The MUTC will generate an alert upon receiving major faults.
  - 4.8.20.2.5 The VPS state and status (working properly, minor fault, major fault) will be display on the Signalized Intersection views.
  - 4.8.20.2.6 The Signalized Intersection definitions shall include the ability to define the VPS position and states.

Further requirements for the VPS monitoring will be finalized during the PDR and CDR phases.

## 5 System Description

### 5.1 System Architecture

The MUTC components will be hosted on the AHCOT IT environments, which include both an on-prem IT environment (AHCOT Network environment).

The following scheme describes the HLA (High-Level Architecture) of the AHCOT Network environment and its interfaces. The MUTC main servers (highlighted green) and all its components (databases, client stations) shall be integrated into these environments.

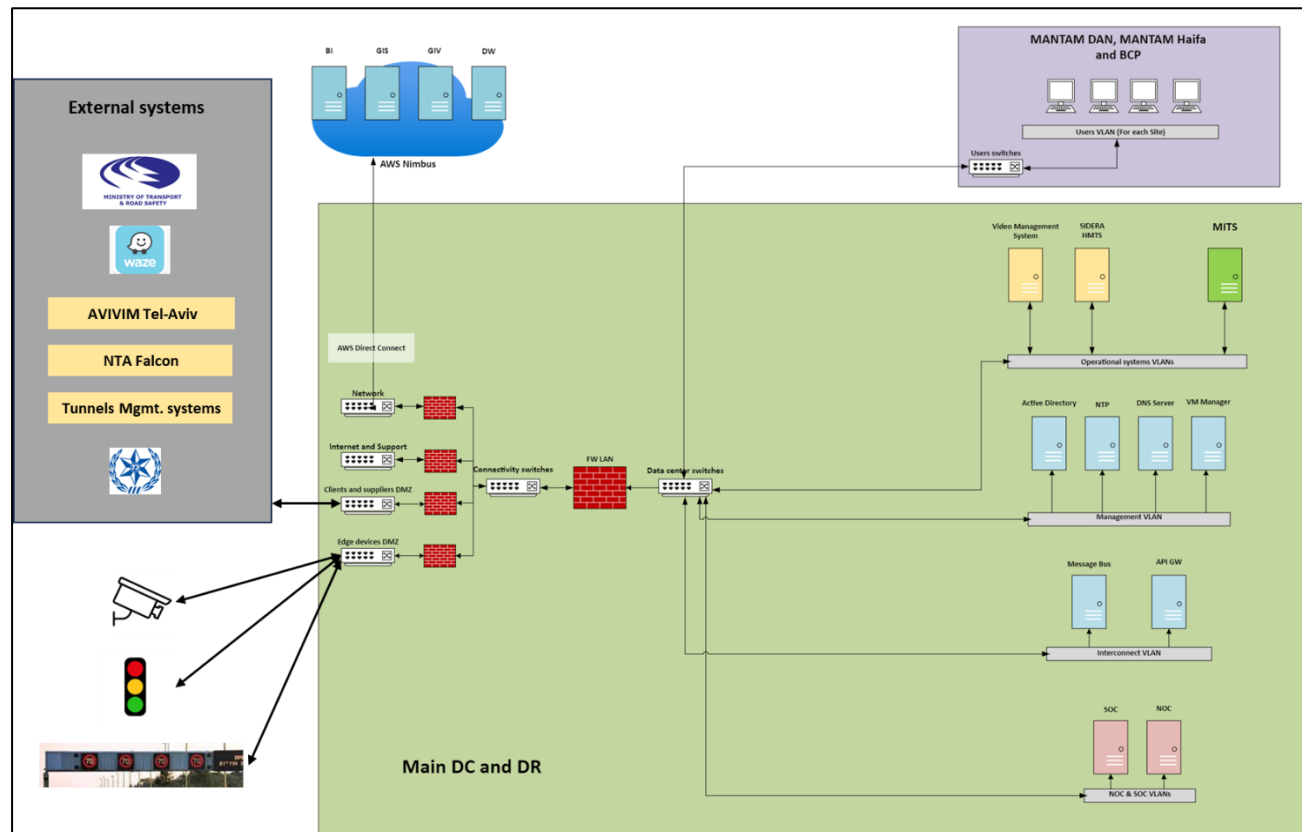

Figure 16 - AHCOT OT environment architecture

#### 5.1.1 MUTC internal HLA

The internal architecture of the MUTC shall be modular and be combined from several loosely coupled layers and modules. The architecture shall be founded on COTS components and tools wherever they are available and meet the MUTC's requirements.

The following scheme describes the MUTC internal HLA:

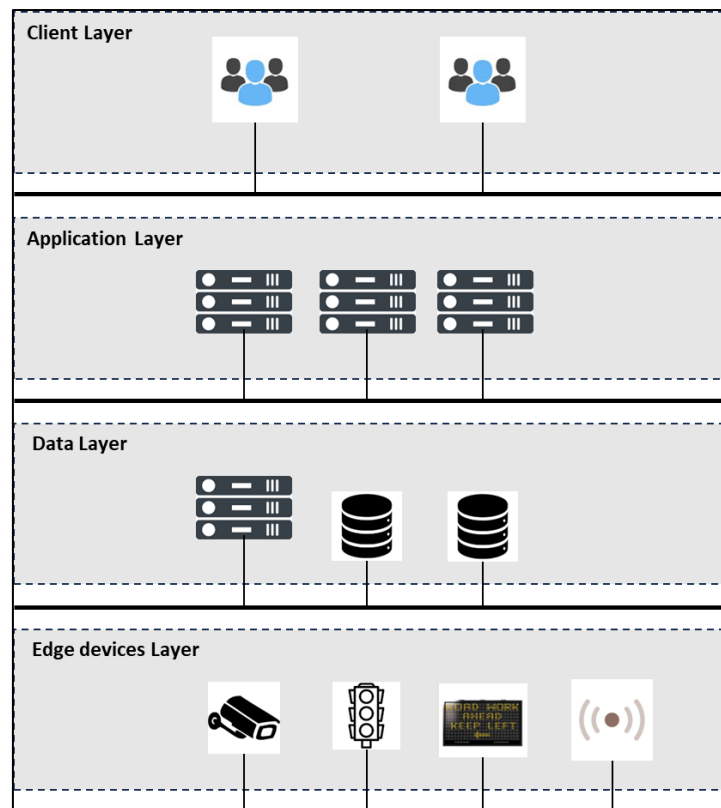

Figure 17 – MUTC internal HLA

#### 5.1.1.1 MUTC layers

The MUTC shall include 4 main layers:

- 5.1.1.1.1 Edge (Outstation) devices layer – The layer will encompass the interfaces to all peripheral devices that supply the MUTC with data to construct the traffic situation picture and controlling effectors, primarily traffic signals and VMS. Outstation devices will be provided as GFE by AHCo.
- 5.1.1.1.2 Data layer – The layer will encompass the internal databases, the collection of interface gateways, and data dissemination services to relevant systems and clients, both internal and external.
- 5.1.1.1.3 Application layer – The layer will encompass all the business logic services of the MUTC, backend services for data processing and data insights, and traffic management and control services. The layer will also include integration services which are required for synchronization between the services.
- 5.1.1.1.4 Client layer – The layer will encompass the user displays and the visualization services.

The services in each layer shall be designed and implemented in a loosely coupled architecture. The interfaces between the services shall be based on standard protocols, the default protocol shall be REST.

In the operational network, various sub-nets will be used to make segmentation between the layers. Other management and network services provided by AHCo to the MUTC will be assigned to distinct network segments as shown in Figure 16.

#### 5.1.2 Data Layer

The data layer encompasses all information necessary to support the traffic management processes of the MUTC. This includes a wide range of data types and formats, both raw and processed. The MUTC services will be responsible for collecting, structuring, and distributing this data accordingly.

##### 5.1.2.1 Databases

The internal databases, whether implemented as a single database or multiple databases, shall fully support the functional requirements of the MUTC. Each database shall be sized appropriately to accommodate the operational demands outlined in this document. The system shall support two modes of data management, centralized through a single database or distributed across multiple databases:

#### 5.1.2.1.1 Transactional DB

The transactional database will serve real-time traffic management processes and must deliver high performance for collecting, storing, and distributing data across the various MUTC modules. The preferred database solution is detailed later in this chapter; however, the Supplier may propose alternative database technologies for use within the MUTC. The final selection of the transactional database will be determined and approved by AHCo by the SDR.

#### 5.1.2.1.2 Archive and analytics DB

The archive and analytical database will store data in a structured, categorized, and easily accessible manner. It will be used for long-term data retention and will support functions such as statistical analysis, calculation of nominal traffic indicators, debriefing, data investigations, and the dissemination of traffic-related information to external stakeholders. The database shall retain all traffic and traffic-related data for a minimum period of seven years.

#### 5.1.2.1.3 File system

AHCo will provide a file system service for storing files such as images and video clips. The system engineer will have the ability to define a configurable retention period for files stored by the MUTC.

### 5.1.3 System Environments

To support the MUTC life cycle, instances of the system shall be deployed across multiple environments, each fully isolated from the others. These environments shall include:

#### 5.1.3.1 Production

The production environment will serve as the primary operational environment of the MUTC, where all core system components will be fully deployed and executed to support real-time traffic management activities.

#### 5.1.3.2 Non-Production

The non-production environment will support multiple phases of the MUTC system life cycle, including testing and evaluation of components before their integration into the production environment, operator training, and the assessment of new traffic management strategies. This environment will function as a sandbox, isolated from external systems, with two controlled exceptions:

- Routine duplication of databases from the production environment to the non-production environment.
- Inbound data from specific, pre-defined interfaces.

These exceptions will be managed by AHCo and permitted only when necessary to support testing or training activities.

## 5.2 Infrastructure services

### 5.2.1 Infrastructure configurations

The MUTC will be hosted on AHCo's infrastructure within the OT network environments. The Supplier shall be responsible for installing all MUTC components on these infrastructures and, where necessary, shall provide, at its own expense, any additional infrastructure required to ensure full system functionality, subject to prior approval by AHCo. As part of the deployment process, the Supplier shall perform a comprehensive survey of the existing AHCo infrastructure to assess the utilization of available services and to identify any additional infrastructure needs or required upgrades to AHCo's systems in support of the MUTC.

### 5.2.2 Infrastructure services

AHCo infrastructure services are detailed in the following sections. The Supplier shall submit a comprehensive list of all required computing resources and infrastructure services necessary for the deployment and operation of the MUTC. This list shall include, at a minimum, specifications for servers, storage, network components, virtualization requirements, and any external services needed to support the system's functionality and performance in all designated environments.

### 5.2.2.1 Communication Infrastructures

AHCo will provide both the passive and active communication infrastructure required for the deployment of the MUTC unless explicitly stated otherwise in this Tender.

### 5.2.2.2 IT Infrastructure

AHCo will provide the IT infrastructure, including servers, storage, and other administrative services required for hosting the MUTC. Accordingly, the Supplier will not be required to supply additional computing infrastructure. However, exceptions may apply in cases where the Supplier requires specialized infrastructure, such as GPUs for high-performance computation tasks. In such cases, the Supplier shall be responsible for providing the necessary infrastructure, subject to prior approval by AHCo, and at its own expense, for all relevant environments.

The following table outlines the detailed on-premises IT infrastructure and services that will be utilized to support the implementation and operation of the MUTC. As these specifications are subject to change prior to system deployment, the final list of services, along with the clearly defined boundaries of responsibility between AHCo and the Supplier, will be finalized and approved by the SDR.

#	Infrastructure	On-prem AHCo site	Responsibility	Remarks
1	Client stations OS and browser	The operating system at the client station will be Microsoft Windows 10/11 or a later version with Microsoft Edge or Google Chrome.	AHCo	
2	Client stations HW	Physical stations with 4core CPU, 8GB RAM, 250GB SSD. No graphical processor.	AHCo	The Supplier shall indicate whether an upgrade is needed.
3	Servers OS	The servers` OS will be Microsoft Windows Server 2022 or a later version.	AHCo	
4	Events reports	Events reports will be based on SNMP and Syslog.	Supplier	Setting up the system components for monitoring
5	Virtual machines	VMware 7.0.3 or a later version.	AHCo	
6	Storage system	Fiber channel configuration, HPE storage system	AHCo	The Supplier will define the required storage resource requirements
7	Storage servers	Fujizo	AHCo	
8	Backup	VEEAM Application The system shall be integrated into the existing backup mechanism. External tape backup to Databank.	AHCo & Supplier	The Supplier will transfer all the data required to back up the application for full recovery. The Supplier is responsible for the MUTC databases.
9	L2 Switching	Server connectivity 10G, redundant	AHCo	The MUTC will be installed in a segmentation configuration based on information security guidelines.
10	Fiber Channel Network	Server connectivity 16 or 32G, redundant	AHCo	
11	Data Center FW L3 & Segmentation	FortiGate \ Checkpoint FW <ul style="list-style-type: none"> <li>Separation between the LAN environment and the WAN environment using a firewall</li> <li>Different segments for each service</li> <li>DMZ&amp;WAN will have a perimeter Firewall.</li> </ul> Separate DMZ for each VLAN.	AHCo & Supplier	The MUTC will be installed in a segmentation configuration based on information security guidelines. The Supplier will characterize the required firewall constitution for the proper operation of the MUTC.
12	Anti-virus + EDR	Trend Micro or any other products	AHCo & Supplier	The Supplier will provide the folders and files that are required not to be scanned for the proper operation of the application. The installation of the antivirus will include all the application components including the

				database in accordance with the organization's information security policy.
13	SOC	QRadar (SIEM) or any other product	AHCo & Supplier	The Supplier will send the information security logs for all environmental components (servers, database, application, etc.) to the central monitoring system and will also allow access to the protocols required for receiving information security logs.
14	AHCo NOC (not including the Supplier NOC)	PRTG MOM & Network - SolarWinds	AHCo & Supplier	The Supplier will send logs to the NOC
15	Internet access	Limited connection, managed by a white list	AHCo	AHCo will open a firewall constitution according to the information security policy for system updates only. Remote access will be enabled in a limited way according to the information security policy.
16	NTP	Microsoft Server 2019 service or a higher version Synchronization against an atomic clock.	AHCo & Supplier	The Supplier will be required to connect the MUTC to a central clock provided by AHCo.
17	DNS	Microsoft DNS services (Windows Server 2019 or higher version)	AHCo & Supplier	The Supplier will be required to connect the MUTC to the DNS services provided by AHCo.
18	Client stations protection	GPO, NAC, antivirus, DLP, separate segment, etc. There may be additional security products according to the AHCo information security guidelines.	AHCo & Supplier	The Supplier will be required to connect the MUTC to the information security services provided by AHCo.
19	SMS	InforUMobile system or any other product	AHCo	The Supplier will use AHCo's SMS services for reporting MUTC Malfunctions to AHCo NOC and Tier 1.
20	Mail	Office 365	AHCo	The Supplier will use AHCo's mail services for reporting MUTC Malfunctions to AHCo NOC and Tier 1.
21	Domain controller	Microsoft Server 2019 service or a higher version	AHCo	All the Supplier's servers will be connected to the domain of the OT environment. The application permissions will be managed from groups through the Active Directory.
22	NAC	CISCO ICE or/& Portnox, ClearPass or/& (snmp-v3 + 802.1x + mac authentication)	AHCo	All client stations will support the 802.1x protocol and the Mac authentication mechanism including installing a certificate for enforcement by the NAC system.
23	CA (certification authority)	Microsoft Ca for internal certificates only	AHCo	All outstation devices are signed with certificates
24	Remote Access	Remote access with VPN & 2FA	AHCo	In accordance with AHCo's policy for maintenance purposes
25	Infrastructure DR	For the virtual components hosted in the shared infrastructure virtual environment (infrastructure DR only)	AHCo	Layer 2 configuration between the DR site and the main site.
26	Applicative DR	applicative DR is the supplier's responsibility	Supplier	

*Table 14 - On-premises IT infrastructure and services*

### 5.3 User workstations requirements

As outlined in the organizational structure of each MANTAM site, the MUTC may be operated by multiple users fulfilling various roles. A typical operator workspace may include one large screen or a dual-screen setup to enable full visualization of the traffic system, data analysis, and command/control interfaces. The MUTC shall support operations across multiple sites, including both primary operational sites and Business Continuity Plan (BCP) sites. Client workstations for the main operational centers—MANTAM Dan and MANTAM Hamifratz—as well as the BCP site, will be provided by AHCo. The expected number of operators displays per site is approximately twenty.

### 5.4 System users' administration

#### 5.4.1 General

The MUTC will retrieve user identities from the OT Network Active Directory and will manage user authorizations based on this identification. Authorization management will define each user's privileges regarding access to system functionalities and interactions with external applications. This includes, for example, permissions to configure traffic metrics and LOS thresholds, control traffic cameras, and manage data dissemination to external systems and stakeholders.

#### 5.4.2 Single Sign On (SSO)

The MUTC will be integrated with AHCo's Single Sign-On (SSO) service. The Supplier will receive the necessary documentation, guidelines, and technical support to ensure proper integration of all relevant system components with the SSO platform, enabling centralized and secure user authentication across the MUTC.

#### 5.4.3 Users' privileges

5.4.3.1 The MUTC shall support role-based access control by enabling each user to be assigned to one or more user groups. Each group will define a specific set of privileges, and a user will be granted the union of permissions associated with all groups they belong to, following a permissive permissions model. Users with administrative privileges will have the ability to create and modify user groups as needed.

5.4.3.2 The following table outlines the main user groups, ranked from highest to lowest privilege. The "Number" column indicates the expected number of users per group at a single operational site; however, the system must be designed to support scalability of twice the initial user volume. During the CDR phase, the Supplier shall propose an updated and detailed definition of user roles and groups for AHCo's approval:

#	Group	Number	Privilege Level
1	System Admin	2	Full
2	Managers (MANATM managers and traffic engineers)	5	Very High
3	Shift managers	3	High
4	Operators	20	Medium
5	Field operators (Rangers)	30	Medium-Low
6	External Clients (Traffic partners)	10	Low
	<b>Total</b>	<b>70</b>	

*Table 15 – Privilege Table A*

5.4.3.3 The following table describes suggested authorizations for each group.

#	Group	Required authorization
1	System Admin	Full access to all the functionality of the system,
2	Managers (MANATM managers and traffic engineers)	As shift manager In addition, managers can create, edit, and delete SIM module entities definitions (Signalized Intersections, Sub-Networks, Configurations, etc.) and other traffic management entities definitions (like metrics definitions, links information, traffic management policies)
3	Shift managers	As operators In addition, can approve the close of events.
4	Operators	Can monitor and apply changes to the Traffic Management Devices to manage the traffic. The operators can create and edit Traffic Event information.
5	Field operators (Rangers)	Can view and edit some parts of the Traffic Event information.
6	External Clients (Traffic partners)	Can view the data but cannot edit it or manage the traffic. In most cases, external clients will be restricted to specific areas or Traffic Management Devices (see next section).

5.4.3.4 The MUTC will allow limiting authorization of groups to

5.4.3.4.1 Specific municipalities. The system will allow users in a group restricted to specific municipalities to view and manage only the Traffic Management Devices that belong to those municipalities.

5.4.3.4.2 Specific Configurations. The system will allow users in a group restricted to specific Configurations to view and manage only the Traffic Management Devices that belong to those Configurations.

5.4.3.5 In addition, a special privilege will be defined for supporting groups, limited to technical layers in the system. The following table describes the supporting groups.

#	Group	Number	Privilege
8	System technical engineer	2	Limited high
9	System cyber team	5	Limited high*
10	System technicians	8	Limited
11	Data analysts	5	Limited high*

*Table 16 – Privilege Table B*

\* Cyber teams and data analysts may also need additional privileges for operational data and functions to investigate cyber events and perform deep analysis.

5.4.4 Total number of users

The number of users specified in the table above represents the total number of users registered in the active directory. During real-time operation, it is anticipated that a reduced number of users will be registered into the system at a single operation site. The expected number of users is presented in Section 5.7. The system shall also enable future growth capabilities of at least 4 times for real-time users.

5.4.5 Municipality access to the MUTC

AHCO may permit municipalities to access the MUTC in a view-only capacity, enabling them to monitor how traffic is being managed within their jurisdiction.

5.4.5.1 The MUTC shall support view-only user workstations, providing municipalities with access to relevant traffic data specific to their geographic area. Each municipality will only be able to view data pertinent to its region; no cross-access to data from other municipalities will be permitted.

- 5.4.5.2 Access permissions and viewing privileges for municipal users will be managed through the AHCo Active Directory, ensuring secure and role-based control.
- 5.4.5.3 AHCo will be responsible for designing and provisioning the network access required to connect each municipality to the MUTC environment in a secure and controlled manner.

## 5.5 Cyber security

### 5.5.1 Compliance

The Supplier must comply with the cyber security certifications based on the standards which are defined in Section 1.6.1.

Note: There may be an overlap between the several recommended listed standards; therefore, the Supplier must indicate which standards it has certification for.

### 5.5.2 Responsibility for cybersecurity

The cybersecurity framework for the MUTC addresses all layers, from infrastructure to the application itself. The implementation of the framework for computing and communication infrastructures is the responsibility of AHCo, however, the Supplier is required to ensure that the MUTC complies and provides a supplementary solution, if needed, with the infrastructure's cybersecurity implementation, such as user identification and authorization, passwords management and interface access control, etc.

### 5.5.3 Secure development

MUTC software development shall comply with secure development guidelines as recommended and guided by the latest version of the following guidelines:

#### 5.5.3.1 OWASP Top 10 Proactive Control Project (OPC)

The supplier shall develop the MUTC following secure coding practices to mitigate vulnerabilities listed in the OWASP Top 10. This includes, but is not limited to:

- 5.5.3.1.1 Secure Input Validation: All user input and data from external sources must be thoroughly validated and sanitized to prevent injection attacks (e.g., SQL injection, XSS).
- 5.5.3.1.2 Secure Data Storage: Sensitive data must be stored securely using appropriate encryption methods in accordance with industry's best practices. AHCo will specify the particular sensitive data that shall securely be encrypted.
- 5.5.3.1.3 Access Control: Implement robust access control mechanisms to restrict unauthorized access to data and functionality.
- 5.5.3.1.4 Session Management: Secure session management techniques should be employed to prevent session hijacking and other session-related vulnerabilities.
- 5.5.3.1.5 Security Configuration: The MUTC and all underlying components must be configured securely with the latest security patches applied.
- 5.5.3.1.6 Error Handling: Implement secure error handling practices to avoid disclosing information in error messages.
- 5.5.3.1.7 Remediation of Identified Vulnerabilities: The Supplier shall be responsible for promptly addressing any security vulnerabilities identified during testing or reported after deployment.

The Supplier shall provide a compliance document outlining the specific OWASP Top 10 recommendations addressed during development and the implemented mitigation strategies; and a summary report from any security testing conducted detailing the identified vulnerabilities and the remediation actions taken. These documents shall be provided at the SDR stage and later stages, 7 days after completion of the security testing.

- 5.5.3.1.8 The Supplier shall address any security vulnerabilities identified during the development process and provide AHCo with a documented record of the identified vulnerabilities and the implemented remediation steps. Records shall be submitted to AHCo within 7 days of the identification of vulnerabilities.

- 5.5.3.1.9 The Supplier shall be responsible for ensuring that all development personnel are aware of the security practices outlined in the SSDLC process and are trained in secure coding techniques.
- 5.5.3.2 SSDLC (secured software development lifecycle) model
- 5.5.3.2.1 The Supplier shall implement a secure software development life cycle (SDLC) in accordance with industry best practices for the development of the MUTC.
- 5.5.3.2.2 The Supplier shall provide a compliance document describing its SSDLC process, outlining the security practices employed throughout the development lifecycle. This document shall be provided by the SDR.
- 5.5.3.2.3 The SSDLC process shall include, but not be limited to the following activities:
- Threat modeling: Identifying and mitigating potential security threats throughout the development process.
  - Secure coding practices: Implementing coding practices that minimize the introduction of security vulnerabilities.
  - Security reviews and code audits: Conducting reviews of code by qualified security professionals.
  - Vulnerability scanning and penetration testing: Identifying vulnerabilities in the developed software through automated or manual testing methods.
  - Secure deployment and configuration management: Following secure practices for deploying and configuring the software.
  - Incident Response Plan: Establishing a plan for responding to security incidents that may occur after deployment.

SSDLC reports containing all of the above development processes will be presented during the CDR.

#### 5.5.4 Security requirements

These above guidelines address, but are not limited to, the following security requirements:

- 5.5.4.1 Software supply-chain protection
- 5.5.4.1.1 Use directories and frameworks from trusted sources that are actively maintained and widely used by many applications.
- 5.5.4.1.2 Make sure that any COTS tools, open-source components, and directories used by the MUTC have an up-to-date and acceptable code signature produced by a well-known code-signing tool (pending permission from AHCo).
- 5.5.4.1.3 Maintain a complete catalog of COTS tools, directories, and open-source components releases utilized by MUTC's Blocks and versions, along with their digital signatures, at all times and provide it to AHCo upon request.
- 5.5.4.1.4 Reduce the attack surface by encapsulating the directory and exposing only the required behavior in the software.
- 5.5.4.2 Secure Database Access
- 5.5.4.2.1 To mitigate SQL injection, untrusted input should be prevented from being interpreted as part of a SQL command by using 'Query Parameterization'.
- 5.5.4.2.2 Ensure that the security controls available from the Database Management System (DBMS) and hosting platform are enabled and properly configured.
- 5.5.4.2.3 All access to the database should be properly authenticated, validated, sanitized, and monitored.
- 5.5.4.2.4 AHCo may require, upon its sole discretion, the MUTC Supplier to include data encryption mechanisms for specific fields or data components within the MUTC databases and storage, for protecting sensitive information.
- 5.5.4.3 Use secured (authenticated, encrypted) communications options.
- 5.5.4.3.1 The Supplier shall implement secure authentication mechanisms between the MUTC and external systems, ensuring compliance with best practice industry standards.
- 5.5.4.3.2 AHCo shall have the ability to specify a bi-directional secure (encrypted and signed) communication mechanism, wherein messages are transmitted or

received to/from external systems. The Supplier is required to offer a configuration mechanism that allows to specify which communication channels should be secured. Implementing the SHA256 encryption standard is essential for ensuring secure communication.

#### 5.5.4.4 Information storage and management

5.5.4.4.1 Encode and Escape Data - All data shall be encoded before the content is passed to the target interpreter to avoid XSS attacks.

5.5.4.4.2 The Supplier will present the concept for protecting and managing the following information:

- Meta data
- Data history
- linked documents.
- Interfaces with the MUTC

The concept will be concluded and approved by AHCo until the CDR.

#### 5.5.4.5 Input validation

The application should check that data is both syntactically and semantically valid (in that order) before using it in any way (including displaying it back to the user). Data validation shall be done on the server side. Data validation through the API gateway is required for accessing the MUTC server, particularly for high-risk interfaces involving external systems.

#### 5.5.4.6 Secured session management

5.5.4.6.1 The supplier shall implement a secure session management system that generates unique, random session IDs transmitted over encrypted channels and securely stored. Sessions must include inactivity timeouts, absolute lifetimes, and mechanisms for renewal upon re-authentication or privilege escalation. Additionally, it must provide robust logging and monitoring of session activities to detect and respond to anomalies, ensuring compliance with security best practices.

#### 5.5.4.7 Digital Identity

The MUTC shall establish and manage a robust digital identity framework to securely identify, authenticate, and authorize users and entities interacting with the MUTC. The implementation must ensure the integrity, confidentiality, and traceability of all digital identities.

#### 5.5.4.8 Password storage and management

Passwords will be stored and managed securely in compliance with industry best practices. The MUTC shall prevent the use of default passwords for all user accounts to eliminate security vulnerabilities associated with predictable credentials. Password storage and management services are part of the domain services which will be provided by AHCo. The MUTC shall only provide any required integration with these services.

#### 5.5.4.9 Enforce access controls

5.5.4.9.1 MUTC modules shall support the RBAC (Role-Based Access Control) model. All MUTC users shall be granted operational system functionalities based on their applied role in MANTAM.

5.5.4.9.2 The MUTC shall support the implementation and enforcement of Multi-Factor Authentication (MFA) for all users accessing it, to enhance security by requiring two or more authentication factors.

5.5.4.9.3 The Supplier will detail, in the PDD document (see Section 11.12.2), all hardening strategies and designs to the MUTC components, based on system hardening standards (CIS, NIST, ENISA, etc.) internal & external e.g. Outstation Devices, servers, and cloud infrastructure. The hardening strategy shall include (but not be limited to) the following elements:

- Software hardening: To update security measures on all applications by editing/updating application code and preventing attacks.
- Network hardening (applicable to the APN network only, if provided by the Supplier as additional workload): To make all communication channels in the network between servers and endpoints secure.

5.5.4.9.4 During the development phase, the MUTC will be connected to the non-prod environment only through FW while access to the environment will be protected with the ZTNA (Zero Trust Network Access) mechanism.

#### 5.5.4.10 Implement Security Logging and Monitoring

5.5.4.10.1 MUTC modules shall produce a security log during their operation.

5.5.4.10.2 MUTC shall produce a structured log file, using standard directories.

5.5.4.10.3 The log shall contain information regarding the following aspects:

- Event description: Unique event identifier, type of the event and timestamp, and detailed description of the event.
- IP addresses: Source and destination addresses related to interface events.
- User information: The user performing the action.
- Privileged users' operations: All actions performed by privileged users within the system.
- Authorization and access: These events include things such as successful and failed authorizations, system access, data access, and application access.
- Changes: These events include changes to data (creation and destruction) and application installation and changes.
- Availability: Availability of events includes startup and shutdown of systems and applications, faults and errors that affect application availability.
- Resources: Resource issues to log include exhausted resources, exceeded capacities, and connectivity issues.
- Threats: Threat logs track suspicious activities or attempts at undermining the security of an application. Some common threat logs include unauthorized access to restricted processes or data, invalid parameters or input, failed authentication, failed security verification such as invalid API keys, and other warnings triggered by the application's security mechanisms.

5.5.4.10.4 The AHCo SOC will have access to all the log files and supplementary data originating from the MUTC. This access will enable the SOC to analyze and diagnose anomalies that could potentially signify a cybersecurity event.

5.5.4.10.5 Additional requirements from the interface to the AHCo NOC and SOC are in Section 5.6.1.

#### 5.5.4.11 Handle All Errors and Exceptions

5.5.4.11.1 All MUTC modules shall handle exceptions and errors.

5.5.4.11.2 Error messages displayed to users do not leak critical data but are still verbose enough to enable the proper user response.

#### 5.5.5 Security Testing

5.5.5.1 The Supplier shall perform comprehensive security testing throughout the development lifecycle of components delivered. This shall include, at a minimum, static code analysis and dynamic penetration testing to identify and mitigate security vulnerabilities. Security testing shall be conducted for any newly developed or integrated code prior to its installation in the MUTC environment.

5.5.5.2 Utilize SAST (Static Application Security Testing) tools throughout the development lifecycle to identify potential vulnerabilities and coding practices that could lead to security issues. The SAST tools should target the programming languages used in the project and be aligned with the SANS Top 25. It is required that the SAST tool be presented at the SRR and receive AHCo's approval. AHCo may request the Supplier to utilize an alternative tool.

5.5.5.3 Implement a SAST scan and code review process that includes security considerations. SAST scan and code review shall be performed for every new code delivered and integrated into the MUTC, prior to installation. Reviewers should be familiar with the SANS Top 25 and be able to identify potential vulnerabilities in the code. Results shall be provided 7 days after completion of each SAST scan and code review.

#### 5.5.6 Penetration Cyber Security tests

- 5.5.6.1 AHCo reserves the right to perform cyber security penetration tests at any time throughout the contract. These tests will be in addition to a formal penetration test that will be conducted as part of the SAT.
- 5.5.6.2 The Supplier shall conduct penetration tests only after receiving formal approval of the testing scope from AHCo. The proposed scope of the penetration test must be submitted in advance for review and approval by AHCo to ensure alignment with AHCo's requirements and expectations. No testing shall commence without such prior approval.
- 5.5.6.3 The tests shall also include the verification of all COTS tools, directories, and open-sources components' digital signatures, based on the Supplier's digital signatures catalog.
- 5.5.6.4 For the purpose of classification of cybersecurity vulnerabilities identified through penetration testing, vulnerability assessments, code review, or any other security activity, the Supplier shall classify each finding in accordance with the Common Vulnerability Scoring System (CVSS) version 4.0, including the applicable score and vector. The severity level of each finding shall be determined based on the relevant CVSS classification levels of Critical, High, Medium, or Low, while also taking into account the operational context and potential impact on the MUTC system, as determined by AHCo.
- 5.5.6.5 Depending on the severity of the identified vulnerability, the Supplier shall be responsible for addressing the identified gaps and providing a corrective solution or patch.
  - 5.5.6.5.1 Critical severity – The Supplier shall perform a technical analysis of the identified cybersecurity vulnerability within two (2) hours of identification and shall propose an immediate mitigation or Work-Around. A final corrective patch shall be provided within seventy-two (72) hours.
  - 5.5.6.5.2 High severity – The Supplier shall perform a technical analysis of the identified cybersecurity vulnerability within one (1) business day of identification and shall propose an immediate mitigation or Work-Around, where applicable. A final corrective patch shall be provided within one (1) week.
  - 5.5.6.5.3 Medium severity – The Supplier shall perform a technical analysis of the identified cybersecurity vulnerability within three (3) business days of identification. A final corrective patch shall be provided within two (2) weeks.
  - 5.5.6.5.4 Low severity – The Supplier shall perform a technical analysis of the identified cybersecurity vulnerability within one (1) week of identification. A final corrective patch shall be provided within one (1) month.
- 5.5.6.6 The Supplier must integrate all cyber security patches and fixes within MUTC's next Version delivery as part of the standard project software development life cycle.

#### 5.5.7 Content Disarm

All files uploaded to the MUTC must undergo a content disarm process before entering the AHCo networks. This process will be performed using the AHCo content disarm services. The specific services will be finalized during the SDR.

#### 5.5.8 Privacy

The data sources for the MUTC may include personal data. Handling personal data must comply with the GDPR guidelines, specifically those relevant to the MUTC:

- 5.5.8.1 Purpose limitation – personal data shall only be used for the purpose for which it was collected, such as the calculation of traffic behavior and events.
- 5.5.8.2 Storage limitation – The Supplier shall implement an anonymization procedure in order to eliminate any personally identifiable information prior to storing the data in the databases.

#### 5.5.9 End of Life (EOL) or End of Support (EOS)

- 5.5.9.1 The system must not use software and protocols that are classified as End of Life (EOL) or End of Support (EOS).
- 5.5.9.2 If a component is declared as EOL or EOS, the Supplier shall be responsible for replacing it within an agreed timeframe. Additionally, until the replacement is completed, the Supplier is required to implement compensating controls, subject to prior approval, to ensure continued functionality and security.

#### 5.5.10 SBOM

The Supplier shall implement and maintain a comprehensive Software Bill of Materials (SBOM) for all software components utilized within the MUTC. The SBOM must enable effective identification, tracking, and mitigation of security threats and vulnerabilities by providing detailed information about software dependencies, versions, and sources.

#### 5.5.11 Integration of the cyber security tools

The integration of the cyber security tools as part of the architecture and the digital signature tools will be carried out in coordination with AHCo and will be concluded until the CDR.

#### 5.5.12 System hardening

5.5.12.1 Operating system hardening (applicable to the hybrid configuration only): To make OS running on all endpoints secure. Techniques include updating patches and limiting accounts with access to the OS.

5.5.12.2 Database hardening: To make the database and the DBMS secure. Techniques include limiting user privileges and access, disabling unnecessary services, and encrypting database information.

#### 5.5.13 Secure web access over the internet

The MUTC shall use a secure web access portal, which will be provided by AHCo, over the Internet to authorized users, allowing them to access the operational servers while maintaining confidentiality, integrity, and availability of data and resources.

5.5.13.1 The web access portal shall be deployed in a DMZ to isolate it from the internal network and minimize the attack surface.

5.5.13.2 A firewall will be implemented, by AHCo, to filter incoming traffic and block malicious requests.

5.5.13.3 All software on the web access portal and servers shall be updated with the latest security patches.

5.5.13.4 Employ secure session tokens with short expiry times to limit the window of vulnerability if compromised.

5.5.13.5 Implement mechanisms to automatically terminate inactive sessions after a defined period.

5.5.13.6 Conduct regular monitoring of the interface and perform periodic reviews of access permissions to ensure compliance with security policies.

5.5.13.7 Establish user sessions only after verifying that the workstation complies with AHCo's network connection policy (See section 5.2.2, item 16 in the table).

5.5.13.8 Implement temporary geographic IP restrictions to minimize exposure.

5.5.13.9 Enable full recording of all user sessions for audit and security purposes.

5.5.13.10 Require additional approval from an authorized party before granting administrator access during connection attempts.

5.5.13.11 The MUTC Supplier shall provide an OpenAPI to establish the connection to authorized MUTC services.

The MUTC OpenAPI implementation must comply with the OpenAPI security schemes that include (but are not limited to) HTTP authentication schemes, API keys, OAuth2 and OpenID connect discovery to allow developers the connect to authorized MUTC services.

### 5.6 Interfaces with AHCo infrastructure services

#### 5.6.1 Network and cyber security monitoring systems

The MUTC modules shall provide an interface and access to the system log files to the NOC (both AHCo NOC and to the Supplier NOC - NOC deployed in the Supplier's facility that monitors all MUTC components) monitoring system and SIEM (QRadar). The interface and log files will contain information about system status, failures, and anomalies. The Supplier shall use a standard logging library to produce the log file, e.g., slf4j, NLog and Logback. The log message shall contain at least the following data:

- a. Timestamp

- b. Log level – Informational level, warn level, error level, fata level.
- c. A human-readable message with information about the reported event

Additional data specific to cyber security is described in Section 5.5.4.10.3 (Cyber security).

The Supplier shall perform a continuous online parsing of the log files to the AHCo SOC, to identify alerts that were designated as such that require an immediate resolution. Once such alerts are identified in the log, an immediate notification/email will be sent to the maintenance teams (both the Supplier maintenance team and AHCo maintenance team) and will automatically open a ticket in the maintenance ticketing system.

The final configuration of the interface and log file will be summarized by the CDR.

#### 5.6.2 Active directory

The AHCo domain controller includes a network active directory which provides authentication and authorization for all the users of the MANTAM. Access by users to all MUTC resources shall be authorized based on the AHCo active directory. The solution may use any additional frameworks or services to proxy the AHCo active directory, but the solution must be based on this active directory serving as the single source of truth for authorization and authentication.

### 5.7 MUTC infrastructure resources

The MUTC will be hosted on AHCo ICT infrastructures. These infrastructures will provide the necessary communication, computation and other services which are required for the MUTC operation. The Supplier shall present in Volume C – Proposed System Compliance Table (items 14, 15), submitted as part of the proposal, the required services, infrastructure, and architecture, based on the list provided in Section 5.2.2.

The resources which are required for the operation will be based on the MUTC characteristics, performance and the growth in data and computation along the system life cycle. The following table represents the currently forecasted users (online users) and traffic management capacities along the MUTC life cycle and shall be used for the design of the required infrastructure resources.

Parameter	Level 1 (Block 1 – versions 1,2)	Level 2 (Block 1 – version 3) - Handover	Level 3 (Max. loads <sup>2</sup> )
Users (as described in Section 5.4.3)	60	100	400
MUTC Interfaces	1 X C2C interfaces 2 X Web interfaces 1 VMS (video) interface	3 X C2C interfaces 5 X Web interfaces 2 VMS (video) interface	8 C2C interfaces 30 Web interfaces 5 VMS (video) interface
Road/s coverage	4000 traffic links	10000 traffic links	50,000 traffic links
Signalized Intersections	800 *Including 15 intersections with central adaptive management	800	1500 Including additional intersections with central adaptive management
Data calculation rate	0.5-5 minutes <sup>1</sup>	0.5-5 minutes <sup>1</sup>	0.5-5 minutes <sup>1</sup>
Multi-Site	2	2	5

*Table 17 - forecasted users and traffic management capacities*

<sup>1</sup> Calculation refers to all required data calculations, such as metrics calculation and LOS.

<sup>2</sup> The purpose of this column is to serve as a reference for the infrastructure design. The Supplier must ensure that no technological constraints are preventing the MUTC from achieving these loads in the future. However, it is not anticipated that the MUTC will reach these loads during the current Agreement.

## 5.8 Multi-site support

The MUTC is required to simultaneously support users located in several traffic control centers with a complete separation of the information, of the Traffic Management Devices and the user interface between the control centers. Each traffic control center is called MANTAM. The MUTC will be installed on a main data center site and on the datacenter of the DR, and each of them will be able to support the simultaneous operation of all MANTAMs. Each MANTAM will be a tenant in the system. As of the date of the Tender publication, AHCo is operating two (2) MANTAMS which the MUTC must support. One is named MANTAM Dan and the second MANTAM HaMifratz.

5.8.1 The required separation will include:

- 5.8.1.1 The data separation of each tenant. For example, the GIS map of MANTAM Dan will only show the Signalized Intersection managed by the MANTAM Dan.
- 5.8.1.2 Each tenant shall have its user displays. MANTAM HaMifratz data will not be displayed in the displays of MANTAM Dan and vice versa. The User interface may be the same, but the data is different.
- 5.8.1.3 Each tenant will manage the Traffic Management Devices separately. Adding, updating, or removing such devices to one MANTAM area of control will not affect the other tenant.
- 5.8.1.4 Each tenant will separately manage its traffic events.
- 5.8.1.5 Each tenant will separately manage the entities and configurations related to the operation of the tenant.
- 5.8.1.6 Authorization will be managed separately for each tenant.
- 5.8.1.7 Each tenant may operate from a distinct control center, which includes workstations and a display wall. It is assumed, however, that all control centers maintain a redundant connection to the OT Network.
- 5.8.1.8 Since the MUTC front-end should be implemented as a web-based application, users with the appropriate credentials can access it regardless of the MANTAM from which they are connecting. For instance, a user holding credentials for MANTAM Hamifratz could be working at MANTAM Dan and managing operations for MANTAM Hamifratz from there.
- 5.8.1.9 Each tenant may have its own interfaces with external systems.

5.8.2 Configuration of tenant

- 5.8.2.1 The Supplier is responsible for defining a tenant for MANTAM Dan including adding and configuring all the existing Traffic Management Devices, connecting to external systems, and configuring any other information needed to migrate the MANTAM Dan from the previous system to the MUTC.
- 5.8.2.2 The Supplier is responsible to define a tenant for MANTAM HaMifratz including adding and configuring all the existing Traffic Management Devices, connecting to external systems, and any other information needed to migrate the MANTAM HaMifratz from the previous system to the MUTC.

## 5.9 GFE description

The following sections describe the GFE which will be provided by AHCo to the Supplier. The Supplier may ask for additional GFE from AHCo who may accept or reject the request. Any additional equipment and services which are not provided by AHCo should be approved in advance by AHCo and shall be provided, at the Supplier's expense.

5.9.1 MANTAM and data center sites

The AHCo sites IT and communication infrastructures and services - MANTAM sites and data center sites will be provided to the Supplier for the installation of the MUTC, as described in Sections 5.2.2.

Communication infrastructures between AHCo sites will also be provided by AHCo.

5.9.2 Outgoing communication requirements

Communication infrastructure with external systems, Outstation Devices, and external data sources

The MUTC will establish many interfaces with external systems, Outstation Devices, and data sources. Detailed descriptions of those interfaces are given in the interface's gateways (Section 4.5.2). AHCo will provide the communication infrastructure between the MUTC production environment to the external systems, Outstation Devices, and data sources. Outstation Devices will be based on secure private APN and fiber-based networks, provided by AHCo. The Supplier is responsible for providing all application services necessary for the establishment of the interfaces.

#### 5.9.3 Testing environment

AHCo will provide the infrastructure of testing environment for the SIAT and SAT. The testing environment is part of the non-production environment which is described in Section 5.1.3.2.

5.9.3.1 The Supplier will install the MUTC in the non-production environment.

5.9.3.2 AHCo shall provide in the non-production environment access for interface testing to external systems and Outstation Devices, both devices provided as GFE and those supplied by the Supplier. If AHCo is unable to provide access to a specific external system in the non-production environment, AHCo may order from the Supplier a simulation module representing the missing external system, as specified in Section 9.2.8.

5.9.3.3 Throughout the Agreement period, and upon AHCo's request, the Supplier shall provide, install, configure, and make available in the non-production environment two (2) units of each type of Outstation Device that the Supplier is required to supply under this Tender, as further detailed in Section 7. Such devices may include, for example, microwave sensors, smart cards for traffic lights, communication/interface components, cellular routers, Adaptive Field Equipment, and other field devices.

#### 5.9.4 User workstation

MUTC's user workstation will be provided by AHCo. The Supplier is required to be compatible with the workstation specification (see Section 5.3) in order to provide the best user experience as detailed in Section 4.7.2.

#### 5.9.5 AHCo NOC and SOC

AHCo NOC and SOC services are under AHCo responsibility, and the MUTC is only required to establish interfaces to the AHCo NOC and SOC services, as detailed in Section 5.6.1.

## 6 System quality and performance requirements

### 6.1 General

This chapter describes system requirements that indirectly impact operational processes and the system life cycle. The requirements are focused on the operation quality of the system, such as operational efficacy and simplicity, as well as the system's scalability for future capabilities expansion.

### 6.2 System Customization and Configuration

The MUTC shall support both flexibility and operational efficiency. Users shall be able to customize the system interface according to their roles and preferences and perform system configurations without requiring downtime. At a minimum, the system shall allow customization and configuration of the following elements:

- 6.2.1 User interface setup – Operators shall have the ability to customize the user interface to match their specific operational needs. This customization shall include the configuration of presentation layers, background layers (e.g., aerial imagery or orthophotos), display objects, and control elements. The system shall also support the definition of geographic areas of interest. Each operator shall be able to save one or more personalized interface configurations, which can be selected either upon login or dynamically during system operation.
- 6.2.2 Operators' authorization – The system shall allow the administrator to define user authorizations based on predefined roles and responsibilities within the MUTC. Modifying a user's authorization may cause minimal access downtime, but only for the affected user(s), without impacting the operation of the system or other users.
- 6.2.3 The MUTC shall allow authorized users to add, update, and delete entities and parameter values necessary for system operation. These configurations shall be accessible without requiring system downtime and include, but are not limited to, the following:
  - 6.2.3.1 Daylight Saving Time change dates.
  - 6.2.3.2 Sunrise and sunset times for each day of the year, with the ability to import this data from an external file.
  - 6.2.3.3 Holidays schedule and special event calendars.
  - 6.2.3.4 Signalized Intersections definitions.
  - 6.2.3.5 Green wave definitions.
  - 6.2.3.6 Traffic entity attribute values, including:
    - 6.2.3.6.1 VC link
    - 6.2.3.6.2 Lane of vehicles \ public transportation.
    - 6.2.3.6.3 Vehicle route
    - 6.2.3.6.4 Intersection
    - 6.2.3.6.5 Sub-network
    - 6.2.3.6.6 Area
  - 6.2.3.7 Traffic metric thresholds and LOS definitions.
  - 6.2.3.8 CCTV attributes and definitions.
  - 6.2.3.9 Traffic detectors definitions (Bluetooth-based detectors, strategic detectors, radar-based detectors, etc.).
  - 6.2.3.10 Predefined areas of interest on the GIS map for quick navigation.
  - 6.2.3.11 Properties and configuration settings for Traffic Events management.

6.2.3.12 Alert message definitions, specifying which types of Traffic Event will trigger on-screen alerts.

## 6.3 Open Architecture

The MUTC shall be designed with an open architecture to facilitate the easy addition, upgrade, and replacement of system components, whether by the Supplier or by third-party vendors. This architectural approach promotes long-term flexibility, interoperability, and scalability.

The principles of open architecture include, but are not limited to:

### 6.3.1 Modularity

The MUTC internal architecture design shall be modular in two aspects:

#### 6.3.1.1 Vertical modularity

The MUTC shall implement a vertically modular architecture, consisting of distinct layers with loosely coupled interfaces between them. This separation promotes maintainability, scalability, and easier upgrades or replacements of individual components.

The architectural layers shall include:

6.3.1.1.1 Data layer – This layer hosts the system's databases and supports data management functions such as ETL (Extract, Transform, Load) and data dissemination to internal and external consumers.

6.3.1.1.2 Application layer – This layer contains all business logic and processing services that implement the traffic management workflows and core functionalities of the MUTC.

6.3.1.1.3 Client layer – This layer includes the user interface components and visual displays, providing interaction points for system operators and administrators.

### 6.3.2 Usage of standards

#### 6.3.2.1 Interfaces

Interfaces between internal MUTC modules, as well as interfaces with external systems and components, shall be based on recognized international standards to ensure interoperability, maintainability, and future extensibility.

The default interface standards to be used in the MUTC shall include, but are not limited to:

6.3.2.1.1 Web standards – Interfaces shall be based on JSON-formatted messages transmitted over RESTful protocols, ensuring simplicity, scalability, and wide compatibility.

6.3.2.1.2 ITS standards – Center-to-Center (C2C) interfaces shall comply with international ITS standards, particularly the NTCIP XML communication standard and the latest version of the Traffic Management Data Dictionary (TMDD). As referenced in Section 4.5.2.2, C2C interfaces may alternatively use web standards, depending on design decisions made during the design review phases.

6.3.2.1.3 C2F standard - Center-to-Field (C2F) interface design shall be based on the NTCIP XML standard, supplemented by relevant Israeli national guidelines for traffic control systems.

6.3.2.1.4 Video standard – Interfaces with video systems shall comply with either the ONVIF standard or WebRTC, supporting flexible integration with various camera systems and video management platforms.

6.3.2.1.5 The Supplier shall provide documented APIs and/or an SDK for third-party integration for selected system functionalities, as may be required by AHCo. The specific functions to be exposed through the APIs and/or SDK shall be summarized and agreed between AHCo and the Supplier during the CDR. The total scope of such exposed functions shall not exceed 20% of the functions available through the GUI.

## **6.4 Scalability**

The MUTC shall be designed to support easy scalability of computing resources, including processing power, memory, and storage, to accommodate evolving operational demands. These demands are expected to increase over time due to the integration of new components, the establishment of additional interfaces, the growth in data volume, and an expanding number of system users, both locally and at remote sites. Resource expansion shall affect only the system's underlying infrastructure and shall not require significant modifications to the application layer or system functionality.

## **6.5 Clients**

The MUTC shall utilize a thin client architecture, where client stations operate without any locally installed proprietary software. All MUTC applications shall run on centralized servers and be accessed through a standard web browser from the client stations. The Supplier shall specify, as part of the proposed MUTC architecture (see Section 5.1.1), the supported web browser(s) and any required commercial software components that must be installed on client stations to ensure full functionality and compatibility with the system.

## **6.6 Backup and Recovery**

The backup and recovery of MUTC data and application components shall be based on AHCo's existing backup and recovery services. This includes the protection of all operational data, user activity logs, technical and diagnostic data, system and user configurations, and MUTC software versions.

AHCo will perform regular backups of all relevant computing infrastructure. The MUTC shall integrate with this service to ensure that all critical application data—including both collected and processed data generated by data analytics modules—is securely backed up and can be fully restored in the event of data loss or system failure.

## **6.7 Configuration Management (CM)**

The MUTC shall incorporate a robust Configuration Management (CM) process to ensure structured and traceable control of system configurations throughout the system's life cycle. The CM process shall provide visibility into and control over all system components and interface configurations, including version tracking, attribute definitions, parameter settings, and performance specifications. Additionally, the CM process shall include continuous image-based backups of the system to enable full restoration in the event of a critical failure or system-wide disruption.

To support efficient implementation and maintenance of the CM process, it is recommended that the Supplier utilize a commercial off-the-shelf (COTS) Configuration Management tool. The selected tool should support automation, auditability, and user-friendly access for authorized personnel, and be integrable with the MUTC's operational and deployment environments.

## **6.8 Failure Contingencies and DRP**

The MUTC shall include a robust failure contingency strategy to ensure continuity of operations in the event of hardware or software failures. The strategy shall be based on the following three pillars:

### **6.8.1 Critical components redundancy**

The MUTC shall provide redundancy for all major system components that are essential to traffic management operations and whose failure would result in a critical or severe operational shutdown (Severity Levels 1 and 2).

Redundant components shall operate in an Active-Active configuration, whereby parallel components run concurrently to ensure continuity of service and immediate failover with no downtime in the event of a component failure. The Supplier shall describe its proposed Active-Active redundancy strategy as part of the system design presented during the SDR.

### 6.8.2 Data Backup

The MUTC shall integrate with AHCo's centralized backup service for all data protection and recovery operations. Data backup shall include all operational data, configuration files, user actions, and any data produced by the system's analytical processes.

The backup approach must comply with AHCo's Disaster Recovery (DR) requirements, which will be finalized during the System Requirements Review (SRR). AHCo provides an on-premise storage infrastructure composed of two replicated storage clusters, one at the AHCo Main Data Center and another at a designated Disaster Recovery (DR) site. The MUTC shall fully support this configuration, ensuring automatic replication and fail-safe storage at the DR site.

### 6.8.3 High Availability / Disaster Recovery

The Supplier shall implement a comprehensive High Availability and Disaster Recovery (HA/DR) solution to ensure system resilience in the event of hardware failure or geographical disruptions.

The DR strategy must meet the following recovery objectives:

- Recovery Time Objective (RTO): Up to 4 hours
- Recovery Point Objective (RPO): Up to 8 hours

The HA/DR approach shall include, but not be limited to:

- Database failover mechanisms
- Server and service replication
- Storage replication
- Automated restoration and failback procedures
- Autoscaling (if applicable)

All HA/DR capabilities shall leverage AHCo's infrastructure services and align with industry best practices for mission-critical systems.

## 6.9 Maintainability

The MUTC shall be designed for optimal maintainability, enabling rapid detection, diagnosis, and resolution of malfunctions to minimize operational downtime.

The system shall support real-time performance monitoring of all application components and proactively detect faults as they occur. It shall include advanced fault isolation and root cause analysis capabilities, allowing identification of the specific component or subsystem responsible for an issue and highlighting affected areas.

The MUTC shall also support customizable alerts and notifications, enabling relevant personnel to be promptly informed of critical faults or performance degradation. Alert mechanisms shall be configurable by severity level, fault type, and stakeholder role to ensure rapid and appropriate responses.

Additionally, the system shall support seamless integration with AHCo's existing monitoring tools and frameworks, providing a unified, consolidated view of the overall system health across all components and subsystems.

## 6.10 System Performance

### 6.10.1 Data and processing loads

This section outlines the estimated scope of traffic and traffic-related data expected to be collected, processed, and managed by the MUTC in the metropolitan areas of Tel Aviv and Haifa. These figures serve as indicative estimates only and are intended to support initial performance evaluations and system capacity planning.

As previously stated, the MUTC shall be designed to accommodate ongoing growth in data volume, including the expansion of traffic devices, monitored events, road segments, and interfaces over time.

Important Note:

The actual volume of data to be handled by the MUTC will depend not only on predefined quantities but also on the characteristics of the data sources and interfaces, data granularity (resolution and frequency), and the specific operational implementation approach of the system.

The expected number of traffic links, intersections, and interface connections to be managed by the MUTC is detailed in Section 5.7.

#### 6.10.1.1 Traffic volume in real-time (urban roads)

- General vehicles – 3,000,000
- Public transportation – 6,000

#### 6.10.1.2 Total Traffic Events per day

- Unexpected Traffic Incidents – 1000
- Planned Traffic Events - 100

#### 6.10.1.3 Traffic devices

- Traffic Light Controllers – as stated in Table 17 - forecasted users and traffic management capacities at Level 3.

#### 6.10.1.4 Amount of traffic detectors (in addition to the detectors connected to the Traffic Light Controllers)

- Cameras – 8000
- Bluetooth and other strategic detectors – 500

#### 6.10.1.5 Metropolitan Area roads

- Urban roads length – 10,000 Km
- Intersections – 4000 (both Signalized and un-signalized)

### 6.10.2 Operation performance, Response Time, and Latency

6.10.3 The MUTC shall meet the following general performance thresholds to ensure real-time responsiveness. The Supplier is advised that additional specific latency requirements may apply to certain data sets or modules as dictated by their operational criticality:

6.10.3.1 Refresh Rate (General) – User display refresh rate of traffic and traffic-related data shall not exceed 30 seconds.

6.10.3.2 Refresh Rate of SIM displays – Refresh rate of SIM displays shall not exceed 2 seconds.

6.10.3.3 Latency – no more than 30 seconds from data collection, raw data, and calculated data, until disseminated to user display and relevant module or system. This latency excludes video streaming which needs to be displayed online with no latency.

Note: Default dissemination of information to the external system will depend on requests from the external system. The data shall only be available for dissemination. In case a push mechanism is defined, the latency shall also be no more than 30 seconds.

#### 6.10.3.4 Update rate

6.10.3.4.1 The update rate of data from detectors shall not exceed 2 seconds.

6.10.3.4.2 Calculated data such as metrics and LOS shall be updated at least every 5 minutes. Performance and latency thresholds for calculated data are subject to the operational criticality of the specific data set; consequently, these thresholds may vary within a range of 30 seconds to 5 minutes.

6.10.3.4.3 Traffic Events shall be updated according to the information changes.

6.10.3.4.4 The update rate for each data type will be defined by AHCo at the SDR phase but is supposed to be on the same scale.

6.10.3.5 Response time – The MUTC modules' response time to requests from the operator shall not exceed 300 msec. This refers to the initiation of a process in the MUTC, the processing time depends on the content of the module process. The module shall provide the user with the expected and actual response time to execute the request.

For example:

6.10.3.5.1 If the operator requests to display a new layer in the TSPD, the GIS module will be initiated within 300 msec and provide the result within the GIS's processing time.

6.10.3.5.2 If the operator requests to calculate metrics on a specific route, if not already calculated and stored on the route, it must be initiated within 300 milliseconds of the request and provided within 0.5 to 5 minutes, depending on the type of metric. The operator will be informed of the process (initiated, expected time to complete).

### 6.11 Reliability and Availability

The MUTC is expected to operate 24/7 with minimal downtime. Downtime of the system may only occur during major updates. Maintenance is also expected to be performed during system operation with a minimum downtime of specific components.

#### 6.11.1 Reliability

##### 6.11.1.1 MTBF (Mean Time Between Failures)

The MTBF of any failure level severity shall not be less than a week.

##### 6.11.1.2 MTBCF (Mean Time Between Critical Failures)

Critical failures are major failures in the MUTC critical modules which cause downtime to one or more of the major traffic management processes. These failures are regarded as severity level 1 or 2 as described in sections 14.19.1.6 and 14.19.2. The MTBCF shall not be less than a month.

#### 6.11.2 Availability

Availability refers to the probability that a system performs correctly at a specific time instance. The MUTC availability during a time instance of any 12-month period shall be above 99.9%.

#### 6.11.3 Maintainability

The MUTC shall be designed to allow fast handling of any Malfunction which causes system downtime. The MTTR (Mean Time to Repair) of system Malfunction shall be according to the response and correction times as detailed in Section 14.19.2

Standard and periodic system maintenance shall not require system downtime.

The MUTC shall enable to perform most of the system maintenance, both planned and malfunctions handling, by an interface to the maintenance center and will not require arriving at the MANTAM site.

#### 6.11.4 Testability

The MUTC shall support performing both online and offline tests to check its functionality and performance. These tests will be performed in a training mode in order not to influence the real traffic operational processes.

The tests may include the injection of simulated data to check the performances of the different components' functionality and interfaces. Simulated data shall be labeled clearly to be ignored by the traffic management operators.

## 7 Supplying and installing field devices for Adaptive Signalized Intersection

### 7.1 General

- 7.1.1 The Supplier shall provide all Adaptive Field Equipment needed to manage the Signalized Intersection through the MUTC central adaptive management module, along with any ancillary gear and consumable accessories required for installation, housing, connectivity, power supply, and other components, at the designated installation sites. This shall include, where the available space in an existing cabinet is insufficient, the provision and installation of an additional cabinet, including all accessories, fittings, and related works required for its proper installation and operation.
- 7.1.2 The purposes of Adaptive Field Equipment may include, among others:
- 7.1.2.1 Counting vehicles and measuring traffic volumes along the road, including determining travel times, speeds, and the like – all as required by the central adaptive management module.
  - 7.1.2.2 Detection and identification of special vehicles approaching the intersection.
  - 7.1.2.3 Detection and identification of pedestrians.
  - 7.1.2.4 Transmission of information to the MUTC system.
  - 7.1.2.5 Translation of instructions from the central adaptive management module to the Traffic Light Controller.
  - 7.1.2.6 Distribution of the adaptive management logic to the intersection level.
- 7.1.3 . All procurement, installation, and maintenance of Adaptive Field Equipment for the POC of the centralized adaptive management module, as described in Section 4.8.19, are covered by the price proposal for the basic system (Part 1 of the Price Proposal). Any procurement, installation, and maintenance of Adaptive Field Equipment for additional Signalized Intersections beyond the POC's Signalized Intersections shall be carried out as part of projects where the MUTC implements adaptive traffic management from time to time, and each such implementation shall be considered a "Project," carried out in line with the orders of AHCO as part of its execution tasks. Such works shall be treated and priced as a Change Order, as detailed in the Agreement.
- 7.1.4 This section details the general minimum requirements regarding the capabilities and characteristics of the Adaptive Field Equipment and does not determine the type of technological solution required.
- 7.1.5 During the POC, as outlined in section 4.8.19.3, and especially after it's completed, the technical requirements for the Adaptive Field Equipment, along with the guidelines for installing the end equipment, will be finalized by AHCo. By signing the agreement, the supplier agrees to comply with follow AHCo's final guidelines once they are published on future Projects if such Projects will be ordered.
- 7.1.6 The Supplier must deliver the products as outlined in its Tender proposal. If the supplier has suggested, either in the Tender response or a separate request, solutions with features beyond those specified in this section, they will still be required to provide the final equipment according to their proposal and meet the rest of the Tender requirements.
- 7.1.7 It is the Supplier's responsibility to install, implement, and maintain device management software necessary for the management, control, monitoring, calibration, and maintenance of the Adaptive Field Equipment. Access to this software shall be limited to users authorized by the Supplier and the company. The installation of endpoint management software will be carried out as part of the MUTC package in the OT network.
- 7.1.8 The Supplier shall be required to provide full Warranty Services (as defined below) for the Adaptive Field Equipment supplied to AHCo or its representatives, including the management software it installed. The warranty shall be provided in accordance with the specifications outlined herein as well as the manufacturer's warranty – with the higher level of service taking precedence, as determined by AHCo.
- 7.1.9 It is clarified that the Supplier shall not be entitled to any additional compensation for the procedures and requirements detailed in this document, except where explicitly stated otherwise, and that in its price proposal, the Supplier has taken into account all requirements and conditions detailed in this document – including transportation, insurance, labor, supervision, warranty, storage, and any other direct or indirect costs associated with providing the services as specified in this document.

- 7.1.10 Where works relating to the Adaptive Field Equipment require coordination with maintenance contractors engaged by AHCo under separate contracts, AHCo shall introduce the relevant contractor and require its cooperation with the Supplier. Thereafter, the ordinary technical and operational coordination shall be carried out directly between the Supplier and the relevant contractor. If gaps, disputes, delays, or lack of cooperation arise and are not resolved directly within a reasonable time, AHCo shall intervene and act as the deciding and coordinating party. The Supplier shall not be held responsible for delays caused by such contractor, provided that the Supplier has acted in a timely, reasonable, and documented manner

## 7.2 Supplier responsibilities

This chapter outlines the Supplier's responsibilities for physically installing or retrofitting Signalized Intersections into those managed by a centralized adaptive module through the MUTC. Including the deployment of required detection devices, system calibration, integration with the MUTC, and the mitigation and management of external conditions such as physical protection, environmental constraints, and data privacy requirements.

### 7.2.1 General Supplier Responsibilities

- 7.2.1.1 Procurement, supply and physical installation of required Adaptive Field Equipment at a Signalized Intersection to retrofit the Signalized Intersections into those managed by a centralized adaptive algorithm through the MUTC. The required Adaptive Field Equipment will include detectors and any computation devices that may be connected to an existing Traffic Light Controller and to the MUTC.
- 7.2.1.2 In case Adaptive Field Equipment will be connected directly to Traffic Light Controller:
- 7.2.1.2.1 It shall be solely the responsibility of the Supplier to obtain a written signed approval from the inter-ministerial committee for traffic devices at the Ministry of Transport (hereinafter – **'the Devices Committee'**) for the usage of such equipment. See section **Error! Reference source not found.**
- 7.2.1.2.2 It shall be solely the responsibility of the Supplier to coordinate with each traffic light maintenance contractor for the design, development, and integration of the interfaces between the Adaptive Field Equipment and Traffic Light Controller.
- 7.2.1.2.3 AHCo will not pay any additional payments for these actions besides what is stated in the BoQ, not to the Supplier and not to the traffic light maintenance contractors.
- 7.2.1.3 Compliance with applicable international, national, and local traffic, road authority, and safety standards.
- 7.2.1.3.1 Adherence to electrical, communication, environmental, and occupational safety regulations.
- 7.2.1.3.2 Installation of field equipment in accordance with approved permits, regulations, and engineering drawings.
- 7.2.1.3.3 Compliance with applicable data protection and privacy requirements related to installed detection technologies.
- 7.2.1.4 Providing maintenance services for Adaptive Field Equipment the supplier provided as detailed in section 7.9 and section 14.
- 7.2.2 Supplier's responsibilities for installing the necessary field equipment at a Signalized Intersection.
- 7.2.2.1 Design, supply, installation, and commissioning of all required field equipment in intersections.
- 7.2.2.2 Leading the process of securing signed approval for the installation design from both the Road Authority and the local municipal authority.
- 7.2.2.3 Design Temporary Traffic Arrangement plans, manage their approval process, and carry out their execution.
- 7.2.2.4 Provision, installation, and verification of communication infrastructure and interfaces between field equipment.
- 7.2.2.5 Provision, installation, and verification of communication infrastructure and interfaces between the field equipment and the Traffic Light Controller.
- 7.2.2.6 Installation and verification of communication infrastructure and interfaces between the Adaptive Field Equipment and the MUTC, based on the OT network infrastructure. If specifically requested, the work may also include the provision of APN communication infrastructure, such as a cellular router or firewall and SIM card; however, such additional provision shall not be included in the Base Scope and shall be separately priced and implemented as a Change Order in accordance with the Agreement instructions.
- 7.2.2.7 MUTC configuration, calibration, testing, and readiness for operational activation.
- 7.2.2.8 Verification that each Adaptive Field Equipment is monitored by the MUTC.

### **7.3 Communication Infrastructure between Adaptive Field Equipment and the MUTC**

- 7.3.1 The OT network is the communication infrastructure between the MUTC and the Adaptive Field Equipment and between the MUTC and the Traffic Light Controllers. Unless specifically requested, AHCo supplies the OT network infrastructure, and it is considered COTS.
- 7.3.2 The Supplier must take into consideration that the network infrastructure to the Signalized Intersection and the Adaptive Field Equipment is based on private APN (Cellular network) and only some are connected based on fiber communication infrastructure.
- 7.3.3 The Supplier is responsible for adapting the entire solution for Central Adaptive Management module, so it works over a cellular network, without sacrificing the capabilities or performance of the Central Adaptive Management module.

### **7.4 General Requirements for Adaptive Field Equipment**

- 7.4.1 Adaptive Field Equipment and their accessories shall be off-the-shelf products, at the stage of mass production, and supplied for commercial purposes.
- 7.4.2 If Adaptive Field Equipment connects directly to the Traffic Light Controller, the supplier must ensure that supplied Adaptive Field Equipment is included in the "General Specification for the Installation and Maintenance of Traffic Lights - Ministry of Transport 1993" (as updated from time to time). If they are not included in the said specification, the Supplier must obtain approval from the Devices Committee, as stated in section 7.5.
- 7.4.3 Throughout the entire term of the engagement, there shall be a local entity (company, partnership, or private company registered in Israel and operating in accordance with the law), authorized by the relevant device manufacturer to provide warranty services, in accordance with the specification requirements.
- 7.4.4 The Adaptive Field Equipment supplied shall comply with all applicable licenses, standards, and legal requirements in effect at the time of delivery and as may be applicable from time to time.
- 7.4.5 Without prejudice to the generality of the foregoing, the Adaptive Field Equipment to be supplied must meet the cybersecurity requirements in effect at the time of delivery and operation, including compliance with the following standards:
  - 7.4.5.1 All relevant standards from the ISO 27XXX family, primarily ISO 27001 and ISO 27002, and ISO 27032 – Secure Development.
  - 7.4.5.2 ISO/IEC 15408 (or an equivalent international standard) and IEC 18045.
  - 7.4.5.3 Aspects derived from privacy protection requirements according to:
    - 7.4.5.3.1 ISO/IEC 29100 on Information Technology Techniques - Security Privacy Framework.
    - 7.4.5.3.2 ISO/IEC 24760.
    - 7.4.5.3.3 The European Union GDPR standard.
  - 7.4.5.4 EN 62368-1 standard for product safety.
  - 7.4.5.5 ISO 62433 (in its various parts) for the protection of industrial systems / SCADA / industrial networks.
  - 7.4.5.6 Information security regulations for technological infrastructures required according to the "Information Security Policy" document in its updated version published by "Government Online" (a government unit that develops digital means for the Israeli government, in order to enable the public to access government services and information online).
- 7.4.6 The Adaptive Field Equipment and their accessories shall comply with the following radiation standards:
  - 7.4.6.1 EN 301 489-1
  - 7.4.6.2 EN 300 440 V2.1.1
  - 7.4.6.3 FCC part 15.245 / 15.249
  - 7.4.6.4 EN 301 489-3 V2.1.1V2.20
- 7.4.7 Compliance with environmental conditions and EMC for terminal equipment installed by the supplier

- 7.4.7.1 Sealing – IP67 according to EN60529.
- 7.4.7.2 Operating temperature range shall be between -10°C and 70°C.
- 7.4.7.3 Relative humidity shall range between 10% and 95%.
- 7.4.7.4 EMC: 2014/30/EU and EN50121-4, with emphasis on proximity to electrified railway tracks.
- 7.4.7.5 Lightning resistance – IEC 62305.
- 7.4.7.6 Vibrations – ENV EN60068.
- 7.4.7.7 Corrosion and/or any damage due to air and/or soil salinity as found in Metropolitan along the Mediterranean coast, including sites close to the shoreline.
- 7.4.7.8 Protection against all types of rodents.
- 7.4.7.9 Constant winds or gusts up to 170 km/h.
- 7.4.7.10 Required Stability:
  - 7.4.7.10.1 As far as the detectors are camera-type, they are required to have vibration correction capabilities and include image stabilization circuits under wind conditions and mechanical movements from the environment.
  - 7.4.7.10.2 The installation of the detector and all other components on a dual-light pole must be wind-resistant – according to SI 414.
  - 7.4.7.10.3 The installation of the detector and all other components on a dual-light pole must be earthquake-resistant – according to SI 413.
- 7.4.8 Detector type equipment which is connected directly to a Traffic Light Controller is required to comply with the guidelines for integrating detectors in traffic signals – Ministry of Transportation.

## **7.5 Obtaining Approval of the Installation and Operation of Adaptive Field Equipment**

- 7.5.1 If Adaptive Field Equipment has not yet been approved by the Devices Committee, the supplier must obtain approval from the Devices Committee at its own expense and sole responsibility, as a condition for ordering and installing the equipment.
- 7.5.2 In order to obtain approval from the Devices Committee, the supplier must conduct appropriate tests and present to the committee certifications of compliance with the conditions and standards.
- 7.5.3 The supplier must contact the Devices Committee and act in accordance with its instructions, as updated from time to time.
- 7.5.4 When contacting the Devices Committee, the supplier must submit for approval all components of the products that it is offering in the Tender.
- 7.5.5 For the purpose of obtaining approval and testing the relevant end device, the Devices Committee may require conducting a field trial in addition to the POC. The supplier shall act in accordance with the instructions in this regard, including providing all necessary means for conducting the field trial, according to the Devices Committee's procedures (including – supplying the devices, providing technical personnel, diagrams and drawings, coordination with relevant parties, installation, monitoring of the test, dismantling, etc.).
- 7.5.6 The supplier must provide AHCo with copies of all submissions to the Devices Committee and its responses within one business day of their dispatch/receipt, as applicable.
- 7.5.7 In any case, the supplier will not be allowed to offer, as part of the response to Projects (except for the POC), the supply of an Adaptive Field Equipment that has not yet received approval from the Standards Committee.
- 7.5.8 Inter-ministerial Committee website for traffic and safety devices – [link](#).

## 7.6 Work Stages

### 7.6.1 Initiation

- 7.6.1.1 Prior to each Project, AHCo shall detail everything required for the supply of the products and their installation (hereinafter – “Specific Request”), including:
  - 7.6.1.1.1 Project description.
  - 7.6.1.1.2 Installation schedule for the project.
  - 7.6.1.1.3 Specific requirements for supply and installation (including – security requirements, twins, adjustments in end devices, required interfaces, etc.).
- 7.6.1.2 Within two weeks of receiving the specific request, the Supplier must submit a proposal for the Specific Request that includes (all according to the requirements of the Specific Request):
  - 7.6.1.2.1 A technical response to the requirements specified in the request.
  - 7.6.1.2.2 A supply planning document for the Adaptive Field Equipment (including – schedule, supply method, transportation to the sites, etc.).
  - 7.6.1.2.3 An acceptance testing document – detailing outlines and scenarios for performing acceptance tests for the product itself on-site (SAT) as well as part of the adaptive traffic management module in MUTC SIAT).
  - 7.6.1.2.4 A price proposal for supplying the Adaptive Field Equipment and their accessories according to the Project outline and BoQ.
  - 7.6.1.2.5 If required, the Supplier must plan and coordinate a Temporary Traffic Arrangement as described in section 7.6.2.
  - 7.6.1.2.6 Against the request proposal and after its approval by AHCo, AHCo will order the supply of the products.

### 7.6.2 Preparations for Performing the Work

- 7.6.2.1 Prior to carrying out installation and/or modification works
  - 7.6.2.1.1 The Supplier undertakes to coordinate the stages of its work regarding both timing and the nature of execution with the various authorities relevant to the performance of the works, such as municipalities in whose jurisdiction the work will be carried out, the Electric Company, telecommunications companies, the police, cable television companies, and any other infrastructure company. In any case where excavation or drilling work is required, the Supplier will be responsible for contacting and coordinating with the appropriate parties to obtain the necessary licenses and permits (including excavation and/or drilling permits) for the work and/or for passage permits if needed.
  - 7.6.2.1.2 The supplier will be responsible for obtaining all necessary approvals and work licenses for day or night work, as well as for work on holidays and Sabbaths. This applies to both routine tasks and special service work, and all related costs will be covered by the Supplier. These expenses will be considered included in the compensation paid to the Supplier for any type of work.
  - 7.6.2.2 Before starting work, and especially before performing work near infrastructure systems, whether they are marked in plans or not, the Supplier must verify the location of underground and aboveground infrastructures using electronic detection tools and performing potholing, coordinate and order, at his own expense, supervision by the appropriate authority, such as the municipal authority, the government authority, and/or the infrastructure owners.
  - 7.6.2.3 The Supplier must coordinate with all authorities responsible for the facilities and pipelines regarding his work, obtain their approval, and comply with their requirements on site. The Supplier will carry out all temporary protections required by the authorities at his own expense. Any work near such facilities must be done in the presence of a Supervisor representing the facility owners. Dismantling and reperforming work carried out without prior probing will be the responsibility and expense of the Supplier.
  - 7.6.2.4 All costs associated with work near facilities, such as coordination with the authorities and fulfilling their requirements, as well as any other expenses, supervision and oversight by facility owners, disruptions to the contractor's work, etc., due to authority requirements, shall be included in the unit prices.
  - 7.6.2.5 Coordination with the authorities and system owners, obtaining excavation permits, waiting for authority inspectors, etc., shall be within the execution timeframe and shall not constitute a reason for extending the duration of execution.
  - 7.6.2.6 The costs of fulfilling all authority's conditions, including work hour restrictions, are included in the unit prices.

- 7.6.2.7 Below is a partial list of relevant authorities and entities in the traffic control authority and the municipal authority in whose area the Signalized Intersection is located:
- 7.6.2.7.1 Traffic Management and Control Department, Ayalon Highways: To obtain accurate mapping of the Signalized Intersection network and to request supervision of the work.
  - 7.6.2.7.2 Water and Sewage Corporation or Department: To avoid damaging water and sewage lines, the Supplier can schedule a site visit with a representative from the Water and Sewage Department, obtain marking of the water and sewage lines, and coordinate further work in the area of water and sewage lines with them. Works by the Supplier near these facilities shall be carried out only in the presence of a Supervisor from the Water and Sewage Department.
  - 7.6.2.7.3 Drainage Department: The Supplier will coordinate its work in the area of drainage lines with the department and ensure the presence of supervision on behalf of the department during work near existing lines and facilities.
  - 7.6.2.7.4 Lighting Department: The Supplier will coordinate a site visit with a representative of the department in order to receive marking of lighting cables and to coordinate work near the cables and poles. Work by the Supplier near lighting facilities will only be carried out in the presence of an inspector on behalf of the Lighting Department.
  - 7.6.2.7.5 Public Parks Division: The contractor must coordinate work that affects existing landscaping, water pipes used for irrigation, with a representative of the municipality from the aforementioned division.
  - 7.6.2.7.6 Other municipal departments as needed.
  - 7.6.2.7.7 Electric Company: The Supplier shall coordinate and request supervision from the Electric Company at least three (3) days before working near electric poles and underground power lines. Work in the area of electric poles and power lines shall only be carried out in the presence of a Supervisor from the Electric Company, or with their approval. The Supplier undertakes to provide the Electric Company with all possible assistance. Furthermore, the Supplier will have no claim if asked to stop work in the area of the electric poles to allow the Electric Company to carry out its work.
  - 7.6.2.7.8 Company "Bezeq"/"HOT"/"Partner" and any other communication infrastructure owner: The Supplier will coordinate and request supervision from the communication infrastructure company at least three (3) days before work near poles, manholes, and underground communication lines. Work around telephone poles, manholes, and communication lines shall only be carried out in the presence of a Supervisor and with the approval of the communication infrastructure company. The Supplier will have no claims due to the entry of the communication infrastructure company to work on the site. The Supplier undertakes to provide the communication infrastructure company with all possible assistance. Furthermore, the Supplier will have no claims if requested to stop work around telephone poles, manholes, and/or communication lines to allow the communication infrastructure company to carry out its work.
  - 7.6.2.7.9 Israel Police: The Supplier shall prepare Temporary Traffic Arrangement plans as detailed in the contract documents and submit them to the municipal representative for approval by the traffic police. The guidelines for "planning Temporary Traffic Arrangements at municipal work sites" are detailed on the Ministry of Transport website at the [link](#). The Supplier shall employ policemen at its own expense in accordance with police requirements. No separate payment will be made for policemen, and their cost is included in the unit prices. The Supplier shall comply with all traffic police requirements.
  - 7.6.2.7.10 General: It is emphasized that the above list is partial and there are additional authorities such as the Antiquities Authority, KKL (Jewish National Fund), Nature Reserves Authority, infrastructure owners for gas transmission, Israel Railways, cable companies, Mekorot, Shfadan, or any other legal authority.
- 7.6.2.8 Before carrying out the work, the Supplier shall request the final approval of the Inspector for the plans in their possession, as well as instructions related to execution details. No work shall be performed, and no materials or equipment shall be supplied or installed that do not conform to the work plans and the technical specifications approved by the Inspector. The Supplier shall submit to the Inspector at least three (3) printed copies of the plans as detailed below:
- 7.6.2.8.1 Detailed installation diagrams.
  - 7.6.2.8.2 Electrical wiring plans, power and control from the mechanism to all equipment connected to it.
  - 7.6.2.8.3 Measurement plans for the placement and location of all types of equipment on-site.
  - 7.6.2.8.4 Measurement plans for the course and contents of the infrastructure, including piping, passageways, and cabling.

- 7.6.2.8.5 The execution drawings of the work plans shall be on drawing sheets of size A3 or A1 as appropriate, on which the Supplier will add his details and the name of the project engineer who approved the plans. The plans shall be created in AutoCAD in the latest computerized version, according to the AHCo's and its Inspector's instructions.
- 7.6.2.8.6 All plans submitted to the Inspector, as detailed above, shall also be provided in addition to the printed version as DWG files.
- 7.6.3 Execution of the Work
- 7.6.3.1 Against the order, the Supplier must ensure centralized delivery of all items ordered in the Specific Request and hand them over to the Installer.
- 7.6.3.2 All products supplied for the Project shall be new, meaning they have not been installed at other sites prior to their installation in the Project.
- 7.6.3.3 The products shall be supplied in their original cardboard packaging, as packed by the manufacturer.
- 7.6.3.4 It should be clarified that the Adaptive Field Equipment will always remain the Supplier's responsibility, and the Supplier will be liable for any damage. The company will not allocate a site for storing the Adaptive Field Equipment on-site until its installation. The responsibility for storing the Adaptive Field Equipment on-site will rest with the Supplier.
- 7.6.3.5 The Supplier shall deliver the Adaptive Field Equipment to the site where the Project will be carried out nationwide as required, according to the details in the Specific Request and in accordance with the required storage and transportation conditions.
- 7.6.3.6 The Supplier must insure the transportation of the Adaptive Field Equipment to the site according to the insurance requirements detailed in the agreement Section 11.
- 7.6.3.7 The installation of the Adaptive Field Equipment will be carried out by the supplier or by an entity designated by AHCo for this purpose, including the Signalized Intersection maintenance contractor (hereinafter – "**the Installer**"). If the Installer is not the Supplier, AHCo will be responsible for the payment for the work done by the Installer.
- 7.6.3.8 If individual installation of the Adaptive Field Equipment or any of its parts by an authorized representative of the manufacturer is required – the Supplier shall perform the installation themselves, in coordination with the installer and in accordance with the manufacturer's requirements.
- 7.6.3.9 It is the Supplier's responsibility to provide all ancillary equipment required for installation (such as connectors, cabinets, poles, and cables), which are necessary to connect the end device and must be suitable for their intended purpose and of branded company production. The Supplier must obtain the Inspectors' approval of the types of ancillary equipment before installation.
- 7.6.3.10 The Supplier shall coordinate with the Installer the date for product delivery, specifying an expected arrival time. Delivery to the project site will be carried out from Sunday to Thursday between 09:00 and 16:00 only.
- 7.6.3.11 Receiving the products at the Project's site will be done by the Installer's representative.
- 7.6.3.12 During the receiving of the Adaptive Field Equipment at the site, a visual inspection will be conducted to ensure that the equipment has arrived intact and corresponds to the AHCo's order. If the product has a warranty sticker that prevents it from being opened without the presence of a manufacturer technician, the Supplier will be required to coordinate with the manufacturer's representative for the date of receiving the Adaptive Field Equipment at the site. It is clarified that receiving the products at the site does not in any way modify the Supplier's absolute warranty obligations for the Adaptive Field Equipment.
- 7.6.3.13 The Supplier shall cooperate with AHCo and/or the Installer during the installation of the Adaptive Field Equipment accessories, in accordance with the instructions of AHCo and/or the Installer. The required cooperation shall include at least all of the following:
- 7.6.3.13.1 Participation in Project planning discussions, carrying out all tasks determined by the Installer and/or AHCo, and providing all information required in this context.
- 7.6.3.13.2 Providing qualified professionals at the installation site who are authorized to install the product and who will assist at every stage of the installation as required by the Installer and/or AHCo;
- 7.6.3.13.3 Supplying all equipment accompanying the Adaptive Field Equipment as required in the Adaptive Field Equipment specification as proposed by the Supplier.

- 7.6.3.13.4 Providing means for testing the functionality of the Adaptive Field Equipment.
- 7.6.3.13.5 Performing all tests required for the installation of the product and checking its operation, including laboratory tests and any additional tests required by the manufacturer and/or by law.
- 7.6.3.13.6 Carrying out supervisory oversight of the installation work to be performed by the Installer or their representative and/or AHCo.
- 7.6.3.13.7 Configuring the products according to the requirements of the Installer and/or AHCo.
- 7.6.3.13.8 Providing all technical or other information required for the installation, including during the installation process.
- 7.6.3.13.9 Providing an As-Made report upon completion of the installation.
- 7.6.3.13.10 Disposal of waste related to the end accessory.
- 7.6.3.14 Installations will generally be carried out on the right side of the road. Attention should be paid so that in extreme cases an option for installation on the left side may be possible.
- 7.6.3.15 The installation will ensure the required performance of the Adaptive Field Equipment, including a level of vibrations that does not impair the Adaptive Field Equipment's performance or its ability to generate information from the Adaptive Field Equipment.
- 7.6.3.16 The installation will be carried out in accordance with the weight-bearing limitations of all the equipment installed on it, including the combination of equipment such as a fixed camera and a PTZ camera together, multiple detectors together (Radar, Lidar, Bluetooth), or any combination thereof, without causing movement beyond the defined limits.
- 7.6.3.17 The general rule for the planning, supply, and mechanical installation of Adaptive Field Equipment and its mounting components on a pole shall be:
  - 7.6.3.17.1 With the approval of an engineer/structural engineer, including approval for compliance with stability, galvanization, and welding requirements. The Supplier's structural engineer must consider the additional wind sail resulting from the installation of the equipment and their accessories, if required, considering the most extreme weather conditions that may occur at the installation site, in accordance with the values specified above.
  - 7.6.3.17.2 A mechanical adapter shall be supplied and installed together with the Adaptive Field Equipment on the pole.
  - 7.6.3.17.3 The cable will be installed from the Adaptive Field Equipment to the pole cabinet, over the entire required length, and will include protection for exposed cables using metal flexible conduits with appropriate seals.
  - 7.6.3.17.4 Cables will be installed inside the poles up to the exit opening. If this is not possible – within plastic conduit. In any case, exposed cables will not be installed.
  - 7.6.3.17.5 When installed on a dual-lighting pole – all cabling will be routed inside the pole, up to the exit opening. No external cabling along the pole will be allowed, except in exceptional cases approved by the Inspector.
  - 7.6.3.17.6 Inside the pole, electrical and mechanical system cables will be routed in separate conduits, bundled and secured, to prevent free movement and avoid damage to other cables routed in the poles. For the sake of clarity, it is stated that all cabling will be routed inside the pole and within the arms; no external cabling will be routed along the pole and arms.
  - 7.6.3.17.7 In cases where it is not possible to route a cable through the pole and the Inspector has approved an external cable route - the cable will be routed externally through plastic piping.
- 7.6.3.18 If the Adaptive Field Equipment is camera-based, the installation will be carried out in such a way that movement is allowed at the lens focus point of the camera - it will not exceed a setup that impairs the ability to perform analytics on the video from the camera - in wind at a speed of 120 km/h (33 meters per second).
- 7.6.3.19 During the installation phase, the Installer will ensure that the Adaptive Field Equipment is aimed at the area of interest defined during the planning stage. This must be considered with particular attention to the following issues:
  - 7.6.3.19.1 The hidden areas shall not be considered part of the areas of interest.
  - 7.6.3.19.2 If the Adaptive Field Equipment is mounted away from the post using an arm, it is required that this distance does not cause vibrations beyond the

allowable limit.

- 7.6.3.20 The connection between the fixture and the Adaptive Field Equipment shall be coated with anti-corrosive material.
- 7.6.3.21 Electrical connections, where required, shall be made using soldering and insulation with a heat-shrink sleeve.
- 7.6.3.22 A connection with an electrical cable shall terminate in a junction box on a DIN rail of the appropriate size for the current load.
- 7.6.3.23 The connection shall include grounding.
- 7.6.3.24 Cable entries to the Adaptive Field Equipment shall be made through sealed openings protected against weather effects. Cable connections shall be made only via a shielded, flexible, and sealed conduit.
- 7.6.3.25 The screws for opening the enclosure shall be of a type that cannot be opened with standard keys/screwdrivers.
- 7.6.3.26 At each cable connection point, the cables shall be connected through a junction box sealed against rain and moisture (with at least IP-67 protection).
- 7.6.3.27 Upon completion of the installation, the Supplier shall verify the integrity of the installation and the connection, including the reception of traffic data or raw information from the Adaptive Field Equipment, as well as the Adaptive Field Equipment's status indicators.
- 7.6.3.28 If the Adaptive Field Equipment needs to be stored in a cabinet, the Supplier is responsible for procuring and installing the cabinet in accordance with AHCo standards and the Supervisor's instructions.
- 7.6.3.29 All the Adaptive Field Equipment shall be labeled using embossed plastic signage, a P-Touch labeling device, or a sticker that cannot be removed. The labeling shall be in black lettering on a white background, in clear, legible, and indelible text indicating the name and purpose of each item, according to AHCo's instructions. This sticker shall include the following data:
  - 7.6.3.29.1 Assignment of the item to AHCo.
  - 7.6.3.29.2 Delivery date.
  - 7.6.3.29.3 Model name and manufacturer details, serial number identifying the products in the manufacturer's information systems
  - 7.6.3.29.4 The Supplier's service center phone number.
- 7.6.3.30 The installation shall be carried out by authorized personnel. All electrical and grounding work shall be performed according to the electrical standard guidelines and its regulations. In any case of a conflict between what is defined in this document and the Israel Electricity Law of 1954 and its regulations, the stricter standard shall take precedence.
- 7.6.3.31 Electrical connections shall be carried out by a licensed electrician.
- 7.6.3.32 The installation shall be carried out in compliance with all relevant standards, including:
  - 7.6.3.32.1 Guidelines for the protection of pedestrians at work sites on urban roads issued by the Ministry of Transportation, the Traffic Department, and the Road Safety Authority.
  - 7.6.3.32.2 The general specification for construction works issued by the Interministerial Committee for the Standardization of Construction Contract Documents. (Each chapter according to its latest edition).
    - Cast concrete works on site, Chapter 02
    - Construction works, Chapter 04
    - Waterproofing works, Chapter 05
    - Carpentry and steel frameworks, Chapter 06
    - Electrical installations, Chapter 08
    - Painting works, Chapter 11

- Communication installations, Chapter 18
- Locksmith frameworks, Chapter 19
- Road paving, Chapter 51

- 7.6.3.32.3 The general specification of the National Roads Company in its latest edition, Chapter 51, Asphalt Works section.
- 7.6.3.32.4 Israel Standard 934 – Road marking: preparing asphalt roads for painting and its application.
- 7.6.3.32.5 Israel Standard 935 – Materials for road marking.
- 7.6.3.32.6 Israel Standard 61386-24 – Plastic conduit systems for electrical and communication installations, underground installation.
- 7.6.3.32.7 Electricity regulations and the technical specification for electrical and communication works of the Standards Institute (including Israeli Standard No. 900 for safety of household and similar electrical appliances: general requirements, standards to prevent electromagnetic interference for devices operating in an office environment).
- 7.6.3.32.8 AHC Co Standards.
- 7.6.3.32.9 Israel standard 489 – Covers for control cabinets.
- 7.6.3.32.10 Israel standard 658 – Concrete links for control cabinets.
- 7.6.3.32.11 Israel standard 858 – P.V.C. piping for telephone cables.
- 7.6.3.32.12 Israel standard 103 – Steel pipes suitable for threading.
- 7.6.3.32.13 Israel standard 1531 – Polyethylene pipes for underground installation.
- 7.6.3.33 The Supplier shall take all necessary measures to prevent disruptions and malfunctions to pedestrians and vehicle traffic, in accordance with the "Guidelines for Protecting Road Users at Work Sites on Urban Roads" of the Ministry of Transport, the "Guidelines for Planning Temporary Traffic Arrangements at Urban Work Sites" of the Ministry of Transport, and/or in accordance with the "Guide for Traffic Arrangements at Interurban Road Work Sites" of Netivei Israel and the Ministry of Transport, and/or in accordance with the instructions of AHC Co and the police.
- 7.6.3.34 The Supplier shall carry out the installation with minimal impact on traffic and the work of other contractors on site. The Supplier shall perform the work in cooperation and coordination with other parties and contractors at the work site. It is hereby emphasized that the work will be carried out at a site where several contractors are operating and where infrastructure prepared by others is being used. No claims from the Supplier regarding this matter will be accepted.
- 7.6.3.35 Only when necessary and according to the annual permits granted to him by the Israel Police, and only with the approval of the Traffic Management Center, may the Supplier stop the operation of a Signalized Intersection or any other installation. It should be clarified that failure to obtain the annual permits and lack of coordination with the Traffic Management Center shall be defined as a malfunction in accordance with the Liquidated Damages document.
- 7.6.3.36 All works and/or actions carried out by the Supplier during the execution of the work shall be in accordance with the Inspector's approvals and instructions, including but not limited to the installation of Temporary Traffic Arrangements, temporary safety devices, and traffic guidance accessories. The Supplier undertakes to maintain them in good and complete condition throughout the entire work period.
- 7.6.3.37 All installation work shall be carried out in accordance with safety instructions detailed in section 7.8.
- 7.6.3.38 The installation shall be carried out in a stable and safe manner, without sharp edges or the like.
- 7.6.3.39 The installation shall be carried out in a way that preserves aesthetics and does not damage the equipment on which it is installed or nearby installations.
- 7.6.3.40 The installation shall allow easy access for service and maintenance.
- 7.6.3.41 All products and installation accessories shall be resistant to rust or any other type of corrosion.
- 7.6.3.42 Each piece of end equipment shall be supplied with a power cable that complies with Israeli standards.

- 7.6.3.43 Flammable materials shall not be used during installation.
  - 7.6.3.44 The installation shall include protection against rodents - resealing piping with and without cables, sealing of cabinets, entrances to buildings. The pipe sealing will be carried out with polyethylene foam.
  - 7.6.3.45 It is clarified that the Supplier is required to perform the installation of the end equipment in an excellent manner, according to best practice in this field, even if this is not stated in the agreement and/or the approved design.
  - 7.6.3.46 Upon completion of the installation, the Supplier shall participate in acceptance tests to confirm the completion of the installation. The tests will be carried out according to a protocol prepared by the Installer and approved by AHCo. Any defects detected during the acceptance tests will be recorded in a summary report prepared by the Installer and submitted to AHCo at the end of the tests. If the tests are found to be defective due to a failure of a subsystem or a component supplied by the Supplier, the Supplier shall be required to perform any necessary actions and make any required repairs or replacements of the item, at its own expense and according to the requirements of the Installer and/or AHCo.
  - 7.6.3.47 AHCo may conduct additional tests through a third party and using testing equipment provided by a third party, and the Supplier shall bear the costs of the testing and the costs for correcting any defects.
  - 7.6.3.48 In addition to all of the above, the Supplier is required to approve, coordinate, and carry out the installations and preparations for them in accordance with the engineering coordination procedure for projects of Netivei Ayalon Company, and in accordance with Central tender 6-2018 of the Ministry of Finance for the purchase, supply, and installation of passive communication equipment – Appendix 16, Technical Specifications Booklet, Chapter 7 (Supportive Infrastructure for Communication Networks).
- 7.6.4 Completion of Installation
- 7.6.4.1 Within one week after the completion of the installation, the Supplier will be required to provide documentation in Hebrew in a format determined by AHCo. The documentation will include:
    - 7.6.4.1.1 A list of the items that were installed.
    - 7.6.4.1.2 Operation instructions in Hebrew.
    - 7.6.4.1.3 A copy of the acceptance test records conducted on-site, signed by the supplier.
    - 7.6.4.1.4 Procedures for handling malfunctions.
    - 7.6.4.1.5 The Supplier shall document and model, in AHCo's GIS platform (which, as of the Tender publication date, is ArcFM), all works installed in the field, including the location and properties of installed assets, the layout and location of network infrastructure, and any other installation-related information required for proper asset documentation and management.
  - 7.6.4.2 Upon completion of the installation phase, the Supplier will be required to obtain a completion approval from AHCo or its representative (hereinafter - "Completion Approval"). The Completion Approval will be granted to the executing Supplier only after it has fulfilled all its obligations according to the specifications, the directive, and the approved design, and as a condition for the transfer of payment to the Supplier.

## **7.7 Work Supervision**

- 7.7.1 Supervisor's Authority
  - 7.7.1.1 The Supervisor is the representative appointed by AHCo to supervise and inspect the quality of the work and ensure that it is carried out according to the schedule.
  - 7.7.1.2 Supervision of the work and its approval by the Supervisor does not detract from the Supplier's sole and full responsibility for the installations during the Warranty Period and throughout the contract period.
  - 7.7.1.3 The Supervisor may require the Supplier to repair, modify, or demolish work that was not carried out according to the plans or instructions, and the Supplier must, at its own expense, comply with the Supervisor's instructions within the period specified by the Supervisor.

- 7.7.1.4 In the event that the Supplier fails to perform repairs as stated in 7.7.1.3, AHCo shall be entitled to make the necessary repairs by itself or through others at the Supplier's expense. The Supplier will be charged for all expenses related to the aforementioned repairs plus 25% as agreed compensation.
- 7.7.1.5 The Supervisor shall be entitled to disqualify any material or work tool that he deems unsuitable for work. In addition, the Supervisor will be entitled to require the inspection and examination of any material in addition to the tests prescribed by the Israeli standards. The Supplier will not use the material delivered for inspection without the approval of the Supervisor.
- 7.7.1.6 The Supervisor shall be entitled to terminate the work in whole or part thereof, or work in a particular profession, if in his opinion the work is not carried out in accordance with the plans, technical specifications, or instructions of the engineer.
- 7.7.1.7 The Supervisor shall be the sole and final determinant of any question that may arise in relation to the quality of the materials, the quality of the work and the manner in which it is carried out.
- 7.7.2 Supplier Commitment
- 7.7.2.1 The Supplier shall give the Supervisor prior written notice before covering any work in order to allow the Supervisor to inspect it and determine, before it is covered, the proper manner in which the work should be executed. If such notice is not given, the Supervisor may order the removal of the covering from the work or the destruction of any part of the work at the Supplier's expense.
- 7.7.2.2 The Supplier shall provide, at its own expense, any necessary safety measures during the work as required by AHCo. The Supervisor shall have the right to instruct the Supplier to install, at the Supplier's expense, additional safety measures and/or to relocate installed safety measures at his sole discretion. The Supplier shall have no claim and/or monetary demand of any kind regarding such an instruction from the Supervisor.

## **7.8 Workplace Safety**

- 7.8.1 The Supplier must take all measures to maintain the safety and hygiene conditions of the workers and third parties as required by government regulations, other laws, and other contract documents.
- 7.8.2 Regarding workplace safety, the Supplier shall be responsible for implementing the provisions of the "Work Safety Ordinance [new wording]", 1970 published by the Ministry of Labor, and the regulations enacted under it, including providing guidance to its subcontractors and monitoring compliance with the provisions (insofar as work is carried out by subcontractors on behalf of the supplier, according to the agreement's provisions).
- 7.8.3 The Supplier shall comply with the safety regulations and procedures specified by AHCo.
- 7.8.4 The various safety accessories shall be of types approved by the Inter-Ministerial Committee for Traffic and Safety Devices of the Ministry of Transport and installed according to the manufacturer's instructions and the 'Guidelines for the Protection of Road Users at Urban Road Work Sites', 'Guidelines for Planning Temporary Traffic Arrangements at Urban Work Sites', and/or 'Guide for Traffic Arrangements at Intercity Road Work Sites' published by the MOT.
- 7.8.5 The approval of the Supervisor must be obtained for the type of accessories before their delivery to the site. The Supplier is responsible for their transportation, installation on the site, movement during the work stages, routine maintenance and proper functioning, dismantling, and transportation off-site.
- 7.8.6 If the Supplier is subordinated to another contractor (hereinafter – the "Main Contractor"), the Supplier undertakes to cooperate with the main contractor at the relevant work site and to perform the work according to all laws and in accordance with and subject to the main contractor's instructions regarding workplace safety and hygiene rules.
- 7.8.7 The Supplier shall be required to coordinate its work in a manner that complies with the instructions of the Main Contractor, including conveying any instructions received in this regard from the Supplier to its subcontractors and supervising the implementation of the instructions (if work is carried out by subcontractors on behalf of the Supplier, in accordance with the terms of the agreement).
- 7.8.8 The Supplier shall not be entitled to an update of the work schedule (or any other compensation of any kind) for any delay and/or expense arising from compliance (or non-compliance) with safety and coordination instructions with the Main Contractor as stated.
- 7.8.9 All expenses, work, and materials required for the Supplier to meet the requirements of this section are considered included in the unit prices listed in the

BoQ, including the unit price for the maintenance of equipment, and no additional payment will be made to the Supplier for carrying out everything required under this section.

- 7.8.10 Movement on existing roads for the purpose of transporting materials, equipment, or for any other purpose shall be carried out only with vehicles equipped with pneumatic tires. Any damage caused by the movement of vehicles belonging to the Supplier shall be repaired immediately by them at their own expense to the satisfaction of the Supervisor.
- 7.8.11 The Supervisor may stop the Supplier's work if it is being carried out under poor or unsafe conditions that do not meet the authorities' requirements and/or the Supervisor's requirements. The Supplier releases AHCo from all liability for any damage caused to structures, the work, the workers, and/or any person, all in accordance with the general agreement. Compliance with all the above will be at the Supplier's expense and will not be subject to payment.

## **7.9 Product Warranty Services After Installation**

- 7.9.1 Upon receiving confirmation of the completion of the installation of Adaptive Field Equipment in the project, the Warranty Period (as defined in Section 14.3.2 below) shall begin.
- 7.9.2 The warranty shall be in accordance with the company's requirements as they appear in the individual notice regarding the project and according to the provisions of this specification as described in Section 14, and in any case shall include the following (hereinafter - "Warranty Services"):
  - 7.9.2.1 Version upgrades and configuration updates.
  - 7.9.2.2 Technical support.
  - 7.9.2.3 Maintenance of spare parts inventory.
  - 7.9.2.4 Performing preventive maintenance service.
- 7.9.3 If the manufacturer's warranty includes additional warranty components not listed above, the Supplier shall provide them as part of the Warranty Services.
- 7.9.4 The Warranty Period, during which the supplier is required to provide Warranty Services, shall last for the entire Warranty Period of the MUTC system, upon receiving completion approval, or according to the warranty period set by the manufacturer, whichever is longer. If the Adaptive Field Equipment is installed in stages, the warranty shall commence from the date of receipt of the last completion approval in the project.
- 7.9.5 The Supplier is required to transfer to the company or its representatives all warranty certificates received from the manufacturer for the products supplied for the project. In the event that the engagement with the Supplier is terminated for any reason, all warranty documents regarding the rights contained therein shall be transferred to the company and/or its representatives, in a manner that obliges the manufacturer and/or any subcontractor on its behalf to continue providing Warranty Services to the company.
- 7.9.6 After the Warranty Period ends, the company may purchase additional warranty and/or maintenance services for all or part of the Adaptive Field Equipment, for separate payment to be determined according to Section 13 of the Agreement (Change Orders).

## 8 Block 2 components

Block 2 is designed to extend the system from localized urban road control (handled in Block 1) to a holistic metropolitan-wide management layer. Its main objective is to unify the control of all road infrastructures within the metropolitan area, seamlessly integrating urban and inter-urban segments under one coordinated platform.

Block 2 is optional and each component may be exercised by AHCo at its sole discretion and thereafter paid to Supplier as detailed in Section 9 of the Agreement.

### 8.1 DSS extensions for integrative Response Plans

#### 8.1.1 General

8.1.1.1 Under normal conditions, the SIM module, and any external traffic management systems (external UTCs and HTMS) execute their Response Plans according to the pre-defined traffic control plans.

8.1.1.2 In cases where the SIM module and the external systems lack Response Plans to comply with the required traffic policy, e.g., sustaining LOS or traffic metrics thresholds, the MUTC user will use the DSS to define a new Response Plan to be executed.

#### 8.1.2 Analyzing the traffic situation.

The DSS shall analyze the traffic situation and suggest the following solutions:

8.1.2.1 Accept the current situation – in cases where no alternatives are available.

8.1.2.2 suggest trade-offs between traffic anchors – decrease thresholds for one anchor in favor of other anchors, for example, allow higher congestion levels for general vehicles to improve public transportation flow.

8.1.2.3 Request specific Response Plan – request from the SIM module to execute a specific Response Plan, for example, request the SIM to execute an evacuation plan for a route.

### 8.2 Playback

The system shall provide a playback capability that enables users to reconstruct and visualize historical traffic data over a specified time range. The playback shall support a defined set of stored data, including traffic metrics, LOS values, Traffic Events, and device statuses. The playback will be displayed on the user interface, presenting the traffic situation as unfolding in real-time, allowing users to analyze trends, anomalies, and response actions. Users shall be able to select the playback period, control playback speed, and pause, rewind, or fast-forward through the visualization to focus on specific points of interest. The playback includes the ability to display stored data, usually for debriefing and investigations.

#### 8.2.1 Parameters for playback

The operator shall be able to define at least the following parameters for playback:

8.2.1.1 Geographic Area – polygon, road segments

8.2.1.2 Time frame

8.2.1.3 Displayed data – the operator will be able to choose from the data catalog the required data to be displayed, e.g., events, LOS, traffic indices, Outstation Devices status, etc.

8.2.1.4 Playback data related to Traffic Events.

#### 8.2.2 Operating requirements

8.2.2.1 The operator shall be able to select the zoom of the display, and the rate of running the playback, to stop and to go forward and backward.

- 8.2.2.2 The operator shall be able to create a playback file, according to the defined parameters, and store it in the database for later review.
- 8.2.2.3 The operator shall be able to reproduce and visually present the activity of the traffic lights, Push Buttons, detectors, and traffic metrics for a time interval selected by the operator.
- 8.2.2.4 The replay feature will enable operators to replay the data in a continuous mode at normal speed and double speed, step by step (second by second), or jump to a specific time within the selected period.
- 8.2.2.5 If an operator selects to replay data related to a Signalized Intersection, the display will be on a detailed diagram of the intersection including, phases, light bulbs, detectors, and Push Buttons. The presentation shall include all the data collected from the Traffic Light Controller and any additional data from devices connected to the Traffic Light Controller.
- 8.2.2.6 If the operator selects a network of roads, the replay will be shown on the traffic situation picture and will include the metrics and LOS related to each route and Signalized Intersection in the selected network. The presentation will also include the traffic light bulb state of each Movement at each intersection but without the detectors and the Push button information.

### 8.3 Traffic Events module

The following table provides a breakdown of the extra data elements to be gathered and maintained as part of this Block. The system shall be designed with the flexibility to allow system administrators to define additional metadata fields as needed and to assign custom tags (e.g., #police, #military, #accident) to support advanced filtering, categorization, and analytical use in later stages of event review and reporting.

Category	Field
General Data	ID
	Report Date and Time
	Reporter Group (Outstation Device, Emergency Agent, etc.)
	Reporter Name (Specific identity of the reporter)
	Reporter Phone Number
	Traffic Event Type Group (Accident, road obstacle, road maintenance, Malfunction, etc.)
	Traffic Event Type (single-car accident, multi-car accident, traffic light fault, public transportation, etc.)
	Name of the Operator
	Event Results
Location and Time (Multiple for wide area events)	Area of effect
Involved vehicles \ others. (Multiple)	Vehicle type \ pedestrian \ animals \ public transportation
	Number of vehicles\others
Casualties (Multiple)	Injury type (light, medium, severe, fatal...)
	Number of injuries
Event Management (Multiple)	Description
	Take Care group type
	Take Care Group
	Name
	Telephone number
	Report Date
	Report Time
	Arrival Date
Arrival Time	

*Table 18 - Breakdown of the extra data elements*

## 8.4 Integrated traffic policies module

### 8.4.1 General

This module shall enable the MANTAM traffic engineer to define the policies which will direct the traffic operational processes.

### 8.4.2 Definition:

8.4.2.1 Policy - Defines a traffic management goal by combining a specific traffic entity (called a traffic anchor, see 8.4.2.2) with a target threshold values for a LOS or performance metric. For example, a policy might set a maximum average travel time for a certain route, or a limit on delays for public transportation lines. These policies help guide how the system responds to changing traffic conditions.

8.4.2.2 Traffic anchor - A traffic entity that plays a central role in a policy definition and is prioritized within execution of Response Plan. For each anchor, one or more threshold values of relevant LOS or performance metrics (such as travel time, delay, or queue length) are defined. When these thresholds are reached or exceeded, they act as triggers for initiating the corresponding Response Plans.

### 8.4.3 Time-sensitive policies

The policies will be time-sensitive according to dates, e.g., holidays, day of the week, and time of day, and may also be sensitive to known events and environmental conditions.

### 8.4.4 Examples of policies:

#### 8.4.4.1 Public transportation priority:

- Anchor entity: PT route in Petah-Tikva city (specific route)
- Relevant metric: Deviation from average speed
- Threshold: No more than 10 Kmph degradation from nominal value
- Time: Weekday, between 7:00 am to 9:00 am

#### 8.4.4.2 Public transportation priority:

- Anchor entity: PT line number 4
- Relevant metric: Degradation from maximal headway
- Threshold: No more than 3 minutes degradation from maximal headways
- Time: Weekday, between 15:00 pm to 19:00 pm

#### 8.4.4.3 General vehicle congestion:

- Anchor entity: traffic flow LOS route in Bnei-Brak city
- Relevant index: Congestion intensity deviation
- Threshold: No more than 20% degradation
- Time: Weekday, between 15:00-18:00

### 8.4.5 Recommending a Response Plan

8.4.5.1 According to the defined policies the MUTC will recommend a Response Plan to keep the traffic LOS or metrics according to the required policy. The recommendation will be approved by the MANTAM operators.

8.4.5.2 Whenever the MUTC fails to find a relevant Response Plan to maintain the policy as defined, the traffic engineer will then either temporarily update the policy, accept the actual traffic state, or force specific Response Plans.

## 8.5 Traffic Events SLA calculations

The MUTC shall include functionality for monitoring and calculating Service Level Agreements (SLA) related to the handling of Traffic Events by authorized personnel, including employees and subcontractors responsible for resolving such occurrences.

### 8.5.1 SLA thresholds

The system shall support the definition of SLA thresholds, i.e., maximum allowed timeframes, for various aspects of Traffic Events management, categorized by Traffic Event - type and subtype. It shall calculate the actual performance against these thresholds for each tracked aspect and automatically generate alerts or highlight Traffic Events where SLA conditions have not been met.

### 8.5.2 SLA calculations

SLA calculations shall apply only to active Traffic Events that are currently in progress.

### 8.5.3 SLA monitoring exclusion

Not all Traffic Events types shall be subject to SLA monitoring. The inclusion of SLA calculations for specific types will be configurable based on operational policies.

### 8.5.4 Below are illustrative examples of SLA-tracked aspects (not exhaustive):

8.5.4.1 Time taken by the operator to begin traffic management actions in response to the Traffic Events.

8.5.4.2 Time elapsed from notification until the arrival of a patroller at the Traffic Incident site.

8.5.4.3 Time elapsed from notification until the arrival of a subcontractor at the Traffic Incident site.

8.5.4.4 Time taken to reopen traffic lanes closed due to the Traffic Event.

8.5.4.5 Total time required to resolve and close the Traffic Event.

## 8.6 AHCo rangers' management module

AHCo employs mounted patrollers (hereinafter: rangers) on roads that AHCo controls and manages. Rangers respond to Traffic Incident calls, arrive at the Traffic Incident location, assess the situation, and assist in resolving the Traffic Incident. The MUTC shall include a module for managing rangers, as specified below.

### 8.6.1 Rangers' vehicles

8.6.1.1 Users shall be able to define ranger vehicles as system entities with attributes such as vehicle type and areas of responsibility (e.g., roads, kilometer ranges, and polygons). An administrator user shall be able to allocate a ranger vehicle to multiple areas of responsibility.

8.6.1.2 Users shall be able to set the operational status of ranger vehicles, including, for example: inactive, busy (assigned to a Traffic Incident), or available.

8.6.1.3 The user shall be able to associate ranger vehicles with Traffic Incident event-type groups and specific Traffic Incident types that the ranger vehicle is authorized to support.

8.6.1.4 The system shall include a user group named Rangers, whose members shall have access to the ranger tablet application.

### 8.6.2 Allocating a ranger vehicle to a Traffic Incident

8.6.2.1 The MUTC will automatically allocate an available ranger vehicle to a Traffic Incident according to the availability of the vehicle, area of responsibility, the type of Traffic Incident, and the location of the vehicle. If the MUTC is unable to select a ranger vehicle, it will notify the control center that no ranger vehicle is available.

8.6.2.2 Control center operators may manually attach/unattached a ranger vehicle to a Traffic Incident. The MUTC shall be able to attach a ranger vehicle via map and the event management module.

- 8.6.2.3 Rangers may be able to forward an assigned Traffic Incident to another ranger.
- 8.6.2.4 When a ranger vehicle is assigned to a Traffic Incident, the system will generate a notification message to the ranger. If accepted, it will be marked as the time of receiving the notification/responding to the Incident and stored in the Traffic Incident metadata. The system will include a timer to notify the control center if a ranger did not accept a Traffic Incident after a configurable period.
- 8.6.2.5 The MUTC shall provide a user-friendly mechanism for reporting the ranger's time of arrival at the Traffic Incident location. This information shall be stored in the Traffic Incident metadata.
- 8.6.2.6 The System Administrator will set the rangers' authorization to invoke any traffic strategies and policies and change the Traffic Management Device state.
- 8.6.2.7 Both the ranger and the control center can manage the operational state of the ranger vehicle.
- 8.6.2.8 The MUTC will automatically change the state when the logic enables it, for example, if a ranger vehicle is allocated to a Traffic Incident or when the Traffic Incident is declared "closed".
- 8.6.2.9 The MUTC will show each ranger vehicle's location, status, and attached Traffic Incident, on the map (geolocation, icons with status) and on a dedicated table-based display.
- 8.6.3 Ranger application on the tablet
  - 8.6.3.1 Ranger vehicles will be equipped with tablets that provide access to the MUTC, featuring online communication capabilities with the system through a secured private APN. Unless stated differently, the tablets will be provided as GFE by AHCo.
  - 8.6.3.2 The rangers will use the tablets to access the ranger application which will be an extension of the MUTC. Through the ranger application, the rangers will see -
    - 8.6.3.2.1 The situation awareness picture,
    - 8.6.3.2.2 Receive and accept requests to manage Traffic Incidents.
    - 8.6.3.2.3 Update Traffic Incident information.
  - 8.6.3.3 The ranger application's user display will be adjusted to the screen resolution of the tablet.
  - 8.6.3.4 The ranger application will run as a web-based application on the tablet and not as a desktop or as a mobile app.
  - 8.6.3.5 The UX of the application on the tablet should be updated to feature a modern, mobile-friendly look and feel.
  - 8.6.3.6 The application on the tablet will only show the required information for the patroller.
  - 8.6.3.7 The MUTC will show the ranger the exact location of Traffic Incidents on a map-based view.
  - 8.6.3.8 Rangers shall be able to update Traffic Incident information, including the addition of media files such as photos and videos.
  - 8.6.3.9 The ranger application shall provide direct access to the tablet's camera for capturing photos and videos.
  - 8.6.3.10 The login process of a ranger to the MUTC will include the selection of a specific ranger vehicle. The name of the user will be stored as the 'responsible owner' of the Incidnet if a Traffic Incident is handled by the ranger.

## 8.7 System architecture – Hybrid configuration

### 8.7.1 General

Hybrid architecture: some of the modules of the MUTC will be deployed in the AHCo AWS NIMBUS landing zone or migrated from the AHCo on-premises environment to the landing zone. The hybrid configuration shall encompass the complete installation of the specified modules in the cloud, at all environments – production, non-production, and the DR. Until the SDR, the Supplier may propose the pre-installation of the modules in Block 1, even though the hybrid configuration requirement is established for the MUTC Block 2.

The following diagram illustrates the hybrid architecture configuration:

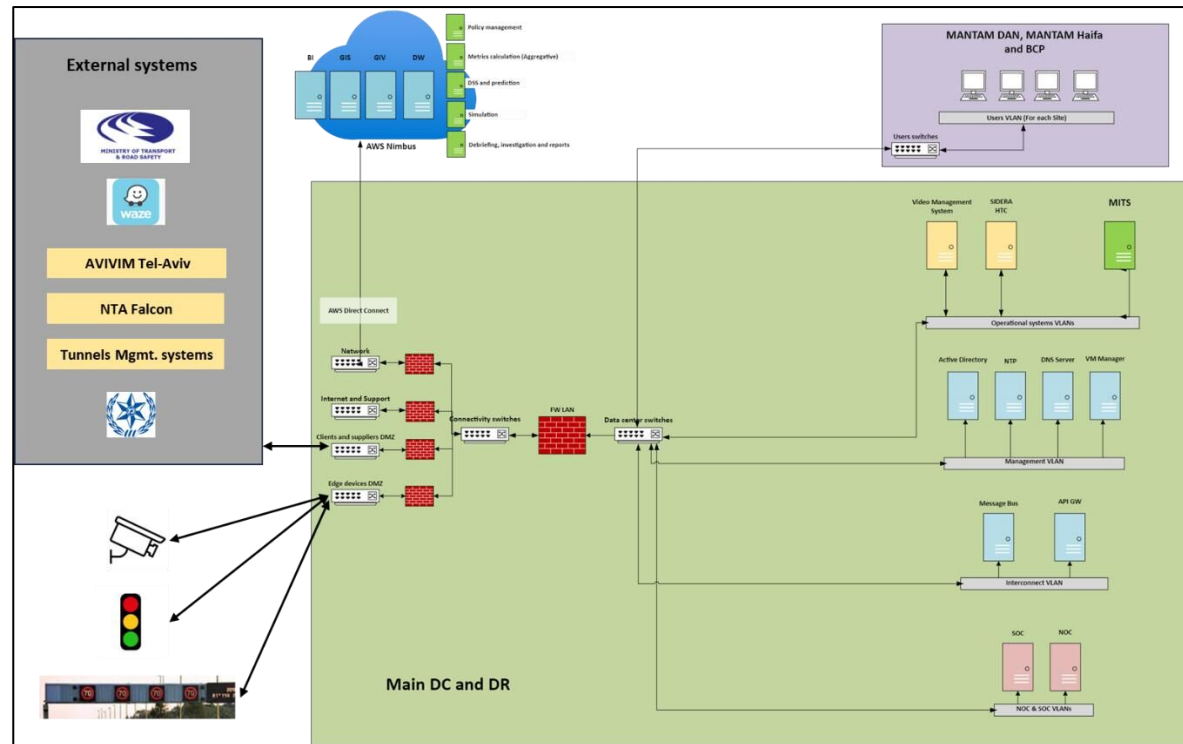

Figure 18- Hybrid architecture configuration

Following are the services and modules of the MUTC which shall be installed in the cloud:

- 8.7.1.1 Interface gateways to external systems – Includes interfaces to any external system which is not located in the AHCo OT environment: Waze, public transportation authority systems, and other external systems (if ordered from the workloads).
- 8.7.1.2 Data dissemination services to external clients – This service regards the generic REST API service as described in Section 4.5.2.6.
- 8.7.1.3 Traffic metrics and LOS calculation module – as described in Sections 4.6.2.
- 8.7.1.4 DSS module – as described in Sections 4.6.4.
- 8.7.1.5 Reports module – as described in Sections 4.6.5.
- 8.7.1.6 Traffic Events management module – as described in Sections 4.7.3 and 8.3
- 8.7.1.7 Traffic policies module – as described in Section 8.4
- 8.7.2 Cloud infrastructure configuration
  - 8.7.2.1 The MUTC services and modules, which are described above, will be hosted in the AWS cloud environment, at a "landing zone" specified by AHCo (AWS NIMBUS). The Supplier will implement the MUTC services and modules on these infrastructures and consume, all cloud services necessary for the intended operation. Cloud services to be used by the MUTC shall comply with a list of services which are detailed in Section 8.7.3, but the Supplier may request other or additional services which are needed for the MUTC operation. AHCo will be presented with the inventory of services, for approval until the SDR. AHCo may request the Supplier to replace certain services with other equivalent services. The HLA architecture of the proposed solution will be presented as part of the response to the Tender.
  - 8.7.2.2 It is hereby clarified to suppliers that the Government of Israel conducted a central tender 01-2020 for the provision of cloud services on a public platform for government offices and authorized units. As part of the tender, AHCo uses Amazon Web Services EMEA Sarl cloud infrastructure and tools (NIMBUS), and therefore the Supplier must establish, implement, deploy and maintain the MUTC using AWS cloud infrastructure and tool within the specific landing zone and under the same AHCo engagement agreement and terms with AWS, as AHCo's sub-account. For further expansion on the subject, see the ITEM instruction – central tender announcements No. 16.2.2 of the General Accounting Office, which specifies the procedure for establishing a sub-account with AWS EMEA Sarl, the costs of using the services, and other topics. The Supplier shall ensure AHCo has full access to all

account details and stored information, and upon termination of the Period of Engagement, or at any other time as instructed by AHCo, shall transfer to AHCo or any other entity on its behalf, the ownership of such account and full control thereof.

8.7.2.3 The hybrid architecture will also include all interfaces of the cloud services and modules to other MUTC modules, to the client stations which are hosted in the AHCo on-prem environments and to external systems.

- In order to mitigate the risks of high cloud services costs, the Supplier will analyze transaction costs between the on-premises and the cloud environments in the hybrid architecture and will design and implement accordingly database replication and synchronization processes, and workload distribution. The hybrid architecture will be presented at the SDR and will be summarized by the CDR of Block 2.

8.7.2.4 The efficiency and cost of the cloud services consumed shall be monitored on an ongoing basis, as provided in Section 14.8.2.12 below and Section 9.6 of the Agreement.

### 8.7.3 Cloud services

The following table describes the detailed services that will be provided for AWS cloud configuration. The MUTC will consume and use these services based on the MUTC's operational needs. The Supplier may suggest additional services as needed for the MUTC operation. All cloud services will be provided by the Supplier's cloud services account (that will be an account under AHCo agreement with the cloud provider). Several services are not AWS services but will be accessible from the NIMBUS landing zone.

There might be several changes until the date of the implementation and therefore final cloud services and architecture will be determined and approved by the system SDR for Block 2.

#	Infrastructure	Services provided at the landing zone	Responsibility	Remarks
1	Client stations OS and browser	AWS Workstation with Windows OS	AHCo	
2	Client stations HW	Customized – same as on-prem	AHCo	
3	Servers OS	EC2 with Windows Server 2022 AMI	AHCo	
4	Events reports	Amazon CloudWatch and Elastic Logstash	Supplier	Setting up the system components for monitoring
5	Virtual machines	AWS Console	AHCo	
6	Storage system	S3, EFS, EBS	AHCo	The Supplier will define the required storage resource requirements
7	Storage servers	Not relevant		
8	Backup	S3 / Storage gateway (Tape Gateway) / AWS Backup	AHCo & Supplier	The Supplier will transfer all the data required to back up the application for full recovery. The Supplier is responsible for the MUTC databases.
9	L2 Switching	Direct Connect	AHCo	
10	Fiber Channel Network	EC2 Instance type network optimized	AHCo	
11	Data Center FW L3	Checkpoint on AWS	AHCo	The MUTC will be installed in a segmentation configuration based on information security guidelines.
12	Segmentation	VPC and Subnets	AHCo & Supplier	
13	Data Center FW L3 DMZ&WAN Perimeter Firewall	Public and Private Subnets	AHCo & Supplier	

14	Number of DMZ environment	Based on Security Groups (Micro-segmentation)	AHCo & Supplier	The Supplier will characterize the required firewall constitution for the proper operation of the MUTC.
15	Anti-virus + EDR	Trend Micro or any other product (Preferred SAAS)	AHCo & Supplier	The Supplier will provide the folders and files that are required not to be scanned for the proper operation of the application. The installation of the antivirus will include all the application components including the database in accordance with the organization's information security policy.
16	SOC	QRadar (SIEM)	AHCo & Supplier	The Supplier will send the information security logs for all environmental components (servers, database, application, etc.) to the central monitoring system and will also allow access to the protocols required for receiving information security logs.
17	NOC	PRTG / CloudWatch	AHCo & Supplier	The Supplier will send logs to the NOC
18	Internet access	Checkpoint on AWS / Any Proxy solution	AHCo	AHCo will open a firewall constitution according to the information security policy for system updates only. Remote access will be enabled in a limited way according to the information security policy.
19	NTP	Amazon Time Sync Service	AHCo & Supplier	
20	DNS	Route53	AHCo & Supplier	The Supplier will be required to connect the MUTC to the DNS services provided by AHCo.
21	Client stations protection	AWS SSM, EDR Solution (Trend-Micro, etc.), MDM Solution SAAS/ AWS Managed AD	AHCo & Supplier	The Supplier will be required to connect the MUTC to the information security services provided by AHCo.
22	SMS	InforUMobile system or any other product	AHCo	The Supplier will use AHCo's SMS services for reporting MUTC Malfunctions to AHCo NOC and Tier 1.
23	Mail	Same as on-prem	AHCo	The Supplier will use AHCo's mail services for reporting MUTC Malfunctions to AHCo NOC and Tier 1.
24	Domain controller	AWS Managed AD	AHCo	All the Supplier's servers will be connected to the domain of the OT environment. The application permissions will be managed from groups through the Active Directory.
25	NAC	Not relevant, only on-prem		
26	CA (certification authority)	AWS Private CA	AHCo	All Outstation Devices are signed with certificates

27	Remote Access	AWS Client VPN / AWS SSM	AHCo	In accordance with AHCo's policy for maintenance purposes
28	Infrastructure DR	AWS Elastic Disaster Recovery (AWS DRS)	AHCo	Layer 2 configuration between the DR site and the main site.

*Table 19 - AWS Cloud services*

## 8.8 Data Integrity

The MUTC shall include capabilities to ensure data integrity verification, anomaly detection, and data completion by identifying missing or erroneous data from sensors, external systems, and Outstation Devices. The module provides three key outputs: (1) Mapping data completeness across various input sources, (2) Generating warnings for anomalies or corrupted data by comparing values with nominal standards, and (3) Enabling data completion, allowing users to request automatic completion of incomplete datasets, with the option to manually accept or reject the updated data based on confidence levels.

## 8.9 Interface with a cellular router

Traffic Light Controllers are connected to the AHCo OT Network by fiber optic lines or by cellular communication. The MUTC shall have an interface to cellular routers/devices connected to Traffic Light Controllers that will allow:

### 8.9.1 Restart command

Send a remote command to restart the cellular router/device from the SIM gateway.

### 8.9.2 Level of signal reception

Show the level of signal reception as reported by the cellular router/device.

## 8.10 Migrating active Traffic Incidents from the legacy system

### 8.10.1 General

Since AHCo plans to use MUTC as the main system for managing Traffic Incidents in each MANTAM, it needs to have the capability to transfer active Traffic Incidents from the old Traffic Incident management system to MUTC. This will allow the users to smoothly transit from the old system to the MUTC.

### 8.10.2 Definition of active Traffic Incidents

Active Traffic Incidents are those that still require ongoing management. For example, any Traffic Incident not marked as "Closed" or "Rejected" falls into this category.

### 8.10.3 Migration

The Supplier will create and conduct a plan to move or copy active Traffic Incidents from the old system to the MUTC, ensuring the copied Traffic Incidents contain the same information and hold the equivalent status in MUTC as they did in the old system.

### 8.10.4 Minimizing Data loss

The supplier will design the migration plan to ensure minimal loss of information. Before moving forward, AHCo will review and approve the plan, and they will not approve any migration that risks losing critical information.

### 8.10.5 Coordination with the old system contractor.

#### 8.10.5.1 The Supplier will gather required information from the old system contractor about the data structure and the Traffic Incident properties.

#### 8.10.5.2 The Supplier will coordinate a migration plan with the old system contractor.

8.10.5.3 AHC is responsible for making sure the old system contractor is cooperating with the process.

8.10.6 Multisite

The work involves migrating from the old system at two sites – MANTAM Dan and MANTAM HaMifratz – and may be conducted in two separate periods, as agreed upon in the project timeline.

8.10.7 Active Traffic Incident quantity estimation

It's estimated that there will be a few dozen active Traffic Incidents in each MANTAM.

## 9 Additional workloads

### 9.1 Overview

This chapter describes additional workloads, which AHCo **may** request to acquire from the Supplier at any stage of the Period of Engagement. These workloads are not currently part of the required Services and are not included in the Part 1 of the Price Proposal submitted by the Supplier.

However, some workloads are priced in Part 2 of the Supplier's Price Proposal, should AHCo decide to acquire them and Section 9 of the Agreement shall apply. Acquisition of other workloads shall be separately priced as Change Orders according to the terms of the Section 13 of Agreement. The workloads described in this chapter is not exhaustive and do not limit AHCo's right to request, throughout the Period of Engagement, other Change Orders.

When ordered, a dedicated design phase for the workload, which might also include a list of required staff skills and experience, will be conducted to estimate the Supplier's implementation efforts and estimated cost. The Supplier is therefore not required in its Proposal to provide the cost for the workloads.

Several workloads are set as content with a fixed price and are defined in the Agreement.

The following table is a list of the workload components/modules:

#	Title	Section
1	APN network	9.2.1
2	Enhanced SIM Capabilities	9.2.2
3	Adding a new traffic management site	9.2.3
4	MUTC Interfaces	9.2.4
5	Predictive capabilities	9.2.5
6	Additional traffic metrics	9.2.6
7	Integrating 3rd Party Traffic Management Module (TMM)	9.2.7
8	MUTC testing tools	9.2.8
9	Tablets for AHCo's Rangers	9.2.9
10	Advanced monitoring UPS devices	9.2.10
11	VMS message control within Predefined Response Plans	9.2.11
12	Additional traffic strategies	9.2.12
13	WAZE interface extension	9.2.13
14	Reports and dashboards	9.2.14
15	Tiered Personnel Rates	9.2.15
16	Additional Training and Knowledge Transfer Services	9.2.16
17	Integration test with a Traffic Light Controller	9.2.17

*Table 20 - Workloads*

### 9.2 Workloads description

#### 9.2.1 APN network

##### 9.2.1.1 Private APN

9.2.1.1.1 The Supplier will design and provide a private secure APN from Israel's local communication suppliers.

9.2.1.1.2 The private APN will be connected to the Main Site with two transmission network lines for redundancy. Each line is from a different Israel local communication supplier. The transmission network lines will have the required communication bandwidth to support the assumed number of Signalized Intersections connected to the MUTC.

- 9.2.1.1.3 The private APN will be connected to the DR with one transmission network line. The transmission network line will have the required communication bandwidth to support the assumed number of Signalized Intersections connected to the MUTC.
- 9.2.1.1.4 The Supplier is responsible for procuring and supplying the SIM cards along with the monthly necessary communication package.
- 9.2.1.1.5 The Supplier will be responsible for designing and implementing the migration of the existing APN interfaces of the Traffic Light Controllers to the new APN Private Network.
- 9.2.1.1.6 The Supplier will be responsible for the implementation of all cyber requirements specified by AHCo for the Private APN solution.
- 9.2.1.2 Cellular router
  - 9.2.1.2.1 The Supplier is responsible for procuring, supplying, configuring and installing cellular routers which will connect Traffic Light Controllers to the MUTC. The cellular router must support 4G or 5G connectivity and comply with cyber demands.
  - 9.2.1.2.2 The Supplier will apply security configurations to the cellular routers. The required security configurations will be provided by AHCo during the design review for this workload.
  - 9.2.1.2.3 The cellular router shall display the cellular connectivity level.
  - 9.2.1.2.4 Installing the cellular routers within the Traffic Light Controller and connecting them to the Traffic Light Controller will be done in coordination with the Traffic Light Controller maintenance contractor.
  - 9.2.1.2.5 In addition, AHCo may instruct the Supplier to provide cellular routers with support for 5G connectivity. All the above requirements will be applied to it.

## 9.2.2 Enhanced SIM capabilities

The following are advanced SIM capabilities that may be integrated into MUTC and will be requested as additional workloads:

### 9.2.2.1 Priority module – Activation Type B

- 9.2.2.1.1 The Activation Type B for the priority module depends on the ability of the SIM module to act as a priority detector and send signals to the Traffic Light Controllers. The basic concept is as follows:

- Designing and implementing Traffic Signal Timing Plans with priority logic.
- Upon internal logic in the SIM module or input from an external system, the SIM module sends signals (on/off state) to the Traffic Light Controller to mimic priority detectors.

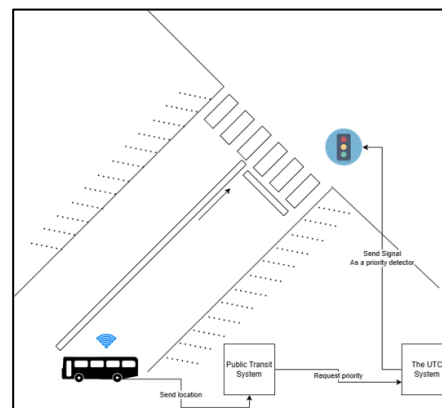

*Figure 18 - Example of Activation Type B priority architecture*

- Figure 19 displays an example. An external public transit system monitors the location of buses. The public transit system checks for running late buses and sends a request to the SIM module to give them priority. The SIM module sends signals to the Traffic Light Controller as a priority detector.

- 9.2.2.1.2 Requirements from the SIM module for priority activation of Type B:
  - 9.2.2.1.2.1 Implement/integrate with requirements 4.8.18.2.1 and 4.8.18.2.54.8.18.2.4.
  - 9.2.2.1.3 The MUTC will provide a user interface to define locations (polygons), and within priority detectors. For each detector, their metadata and connection or relation to Signalized Intersections.
  - 9.2.2.1.4 The MUTC shall provide a secure C2C interface enabling authorized external systems to submit priority activation requests, which the SIM gateway shall validate and forward to the relevant Traffic Light Controllers. Each request will be for a specific location that has at least one priority detector. The activation request can either trigger or deactivate the detector. The interface shall support, as applicable, NTCIP 2306 (C2C XML), TMDD 3.03d or above, DATEX II, and/or a secure HTTPS REST API.
  - 9.2.2.1.5 The SIM module shall collect and store any request for priority activation request, including any metadata about the specific vehicle requesting prioritization.
  - 9.2.2.1.6 If necessary, the Supplier will update the communication protocol drivers with the Traffic Light Controller to allow sending signals as a priority detector from the SIM module. The change to the protocols with Traffic Light Controllers will be coordinated by the Supplier with the Traffic Light Controller suppliers.
  - 9.2.2.1.7 The SIM module will provide a user interface to set a logic to send signals for multiple priority detectors based on the requested triggering location/detector. For example, if the request is at location X, the SIM will send signal to trigger a detector at the stop bar of a Signalized Intersection, and a signal to deactivate an extension priority detector off a different Signalized Intersection.
  - 9.2.2.1.8 Generate a report to display each phase state alongside the priority detectors state, status and data, and the stop line detector state and status for every change of the phase state or of the priority detectors state. User will select the Signalized Intersection and range of date to generate the report.
- 9.2.2.2 Establishing a new Signalized Intersection in the MUTC
 

The Supplier will define and set up a new Signalized Intersection (single or dual) in the MUTC. The work will include defining the settings for network connection, setting up all the intersection definitions, creating the intersection diagram with all the intersection components (lights, detectors, phases, etc.), loading the traffic light programs, managing green waves, and checking the proper functioning of the intersection after the actual connection.
- 9.2.2.3 Defining and setting up Adaptive Signalized Intersection
 

The Supplier will analyze, design, set, and implement all required configurations and definitions to manage a Signalized Intersection in adaptive mode using the centralized adaptive traffic management module. The work will include the adjustment and calibration of the Adaptive Signalized Intersection in the system for at least two (2) months after the activation of the adaptive mode on the Signalized Intersection. In addition, the work will include the design, procurement, supply, and installation of Adaptive Field Equipment for the Signalized Intersection as described in section 7.
- 9.2.2.4 Reading and loading plans from future traffic light planning software.
 

The Supplier will expand the functionality of MUTC to read and load Traffic Light Timing Plans and detectors plans from files generated by future planning software, into the directory of plans managed by the system. The future planning software presumably will generate the files in the unified format as described in E3 – The unified format but it does not guarantee the unified files will contain all necessary information. It will be the Supplier's responsibility to finalize the interface with the new future traffic light planning software.
- 9.2.2.5 Supporting a new version of existing traffic light planning software interface
 

The supplier will update an existing interface with traffic light planning software if a new version and capabilities are implemented in the new version of the traffic light planning software.
- 9.2.2.6 Validate Traffic Light Timing Plan parameters.
 

The SIM module will compare the parameters defined in the Traffic Light Timing Plan from a PDF file generated by traffic light planning software with the parameters stored in the traffic light plan directory. The SIM module will highlight any mismatch between the two sources.
- 9.2.2.7 Supporting new Traffic Light Timing Plans parameters definitions

As the system may expand to include more areas, some of the Traffic Light Controllers in the new area may have been designed according to other guidelines. The SIM module will be expanded to support additional Traffic Light Timing Plans parameters definitions. The system will allow the users to set which definition is relevant for each Signalized Intersection. The system will then use the correct Traffic Light Timing Plans parameters definitions to support and implement all the requirements in this Tender.

#### 9.2.2.8 Dynamic Green Wave Control Strategies

The SIM module shall support Dynamic Green Wave Control Strategies. In a Dynamic Green Wave setup, the cycle length of the Signalized Intersections isn't fixed and can vary from one to another. There are two (2) control strategies of Dynamic Green Wave.

##### 9.2.2.8.1 Control strategy A

The synchronization is achieved using the Signalized Intersections detectors and synchronization pulses that pass between the Signalized Intersections. The SIM module is not directly involved with Green Wave operation. The SIM module monitors the Green Wave operation.

##### 9.2.2.8.2 Control strategy B

The SIM module acts as a proxy to send and receive synchronization pulses between the Signalized Intersections. In this case, The SIM module will implement the following requirements for Dynamic Green Wave – Control strategy B.

- Receive at least eight (8) synchronization pulses from each Signalization Intersections.
- Send at least eight (8) synchronization pulses from each Signalization Intersections.
- Define for each synchronization pulse of a Signalization Intersection a name, source, and target. The source may be local physical source in the Signalization Intersection, Logic instructions defined in the SIM module, and another Signalization Intersection.
- The SIM module will allow users to define logic instructions which the SIM will execute to trigger sending synchronization pulses.
- The SIM module will allow users to force triggering, unforce triggering, and return to normal operation of the synchronization pulses.

##### 9.2.2.8.3 Analyzing the operation of the Green Wave

The SIM module will analyze the operation of the Green Wave in real-time. If the Green Wave is not working as expected, the SIM module will raise an alarm, mark it as working without synchronization, and provide full details about the problem.

#### 9.2.3 Adding a new traffic management site

The main objective of the MUTC is to manage traffic in the Dan and Haifa metropolitan areas; however, as stated in the SOW, the system must be adaptable and flexible to enable the expansion of geographic areas, data, users, interfaces, and processing resources to enable adding new traffic management sites. As a result, AHCo may request adding new MANTAMs (whether managed by AHCo, a municipality, IMOT, or any other entity on its behalf).

##### 9.2.3.1 The Supplier will establish the new site in accordance with the specifications outlined in Section 5.8.

##### 9.2.3.2 The following are the main tasks for adding a new site:

- Establishing new interfaces to relevant external systems.
- Updating the geographical database with relevant data of the new region, such as maps, geographic layers and traffic entities.
- Support new lexicon of Traffic Light Timing Plan parameters definitions.
- Setting rules, indices and traffic policies for the new region.
- Adjusting required authorization for the operators of the additional regions.
- Providing training for additional users.

9.2.3.3 The new site will operate from the MUTC (same application servers) that have already been installed, utilizing the same infrastructure as that defined for it at the Main Site, DR site and cloud, as detailed in this Tender. In the event that the new site necessitates additional computing resources, AHCo will provide them.

#### 9.2.4 MUTC Interfaces

The Supplier may be required, to modify existing interfaces and/or establish new interfaces with additional traffic devices and external systems, as described below:

##### 9.2.4.1 Adding new functionality to an existing protocol to Traffic Light Controller

###### 9.2.4.1.1 Documenting missing functionalities

To support new capabilities of existing Traffic Light Controllers or supporting missing functionalities as requested in this SOW, the Supplier shall conduct a survey and evaluate the functionality of the existing AHCo Traffic Light Controller protocols. The Supplier will then prepare a summary document outlining any missing functionalities within the existing protocols needed to fulfill this SOW. AHCo will review and approve the documentation.

###### 9.2.4.1.2 Designing changes to protocols

The Supplier shall update the protocol documents with all the necessary changes to support the missing functionality. AHCo will review the documentation and approve the documents.

###### 9.2.4.1.3 Implementing the changes in protocols

The Supplier will develop and implement the necessary modifications in the MUTC and its SIM module to support the updated protocol versions. The Supplier will also be responsible for conducting integration tests against the Traffic Light Controllers with each Traffic Light Controller supplier to ensure full functionality.

###### 9.2.4.1.4 AHCo responsibility

AHCo is responsible for issuing requests to all the suppliers of the Traffic Light Controllers to support such changes.

###### 9.2.4.1.5 Supporting multiple versions of interface protocols.

The Supplier must consider that, for a certain period, the MUTC will need to support multiple protocol versions simultaneously.

##### 9.2.4.2 Integrating MUTC with a new type of Traffic Light Controller.

As new Traffic Light Controllers may be approved by the inter-ministerial committee of the IMOT, the Supplier shall adjust the MUTC to manage and control new Traffic Light Controllers based on any of the approved protocols in this Tender or added to the system during the project. The work will include making any necessary changes in the protocols' drivers and conducting an integration process with a Traffic Light Controller supplier.

##### 9.2.4.3 Integrating MUTC with existing type of Traffic Light Controller based on a new communication protocol.

The Supplier shall develop and integrate support for the management and control of Traffic Light Controllers by a new communication protocol selected by AHCo. To be noted that AHCo's preference is to use widely used protocols and standards, but this is not binding. The Supplier will serve as an expert in implementing the communication protocol. If needed, the Supplier will provide professional guidance to the Traffic Light Controller's suppliers, about the communication protocol and how to use it to connect the MUTC. The work also includes an integration process with the existing Traffic Light Controllers' suppliers.

##### 9.2.4.4 C2C Interface with external traffic management systems

Beyond the C2C interfaces specified in Section 4.5.2, the MUTC shall support additional Center-to-Center (C2C) interfaces with external traffic management systems, including NATI's Traffic Management System, additional UTCs, additional HTMS (See specification in section 4.5.2.6), and other traffic control and management systems, to support coordinated traffic management across adjacent jurisdictions and corridors.

#### 9.2.4.4.1 Interface status and monitoring

Each side shall notify, monitor, and report the operational status of the C2C interface (e.g., connectivity, heartbeat, message delivery status, fault indications).

#### 9.2.4.4.2 Exchange of network and asset inventory

Each side shall exchange an inventory of relevant network and field assets located in the agreed areas of interest, including at minimum:

- Road links / segments
- Signalized Intersections / Traffic Light Controllers
- Detectors / sensors

The exact scope and list of exchanged entities shall be defined during the design phase.

#### 9.2.4.4.3 Exchange of timing schedules

Each side shall exchange timing schedules (e.g., time-of-day plans, calendar schedules) for Traffic Light Controllers included in the agreed interface scope.

#### 9.2.4.4.4 Exchange of traffic events

Each side shall exchange information about Traffic Events. The Traffic Events characteristics, structure, and filtering rules shall be defined during the design phase.

#### 9.2.4.4.5 Exchange of network, Traffic Light Controller, and detector State

Each side shall exchange operational status and state information, including at minimum:

- Link status (e.g., metrics, LOS, blocked links, restrictions, direction)
- Traffic Light Controller status (e.g., operational/failed, active plan, flashing-amber/yellow, special modes)
- Detector data (e.g., occupancy, volume, speed where applicable)

The exact content, granularity, and update rates shall be defined during the CDR.

#### 9.2.4.4.6 Display of Received Information

The MUTC shall present information received via the C2C interface on its traffic situation picture, including (as applicable) signal status, Traffic Events, and link metrics indicators.

#### 9.2.4.4.7 Cross-system request to switch signal timing plans

Each side may request to switch the active signal timing plan in a Signalized Intersection managed by the other system, limited to a predefined set of authorized plans.

The MUTC shall support a configuration option determining whether such requests are:

- Applied automatically, or
- Require operator approval prior to execution.

#### 9.2.4.4.8 Cross-system request to switch to set messages on VMS signs

Each side may request to set a message on a VMS sign managed by the other system, limited to a predefined set of authorized messages. Messages will include prioritization definition.

The MUTC shall support a configuration option determining whether such requests are:

- Applied automatically, or
- Require operator approval prior to execution.

#### 9.2.4.4.9 Message set and workflow definition.

A full list of messages, data mappings, and workflows (including security, acknowledgements, retries, and error handling) shall be defined during the design phase of each specific interface.

#### 9.2.4.4.10 Supported Standards and Protocols

The C2C interface shall support commonly used external-system interfaces and be based on one or more of the following, as applicable to the interfaced system:

Traffic management C2C standards / protocols:

- NTCIP 2306 – XML Message Encoding and Transport in C2C Communications (NTCIP C2C XML)
- TMDD 3.03d or above (or equivalent agreed version). TMDD entity schemes may be augmented to include supplementary information required for the exchange.
- DATEX II (version and profiles to be agreed during design), when required by the interfaced system or relevant national/regional deployments.

Modern service-based interface

- Secure HTTPS REST API, in addition to or instead of the above standards, subject to agreement during the relevant release cycle and interface design.

All interfaces shall be designed to enable interoperability, secure data exchange, and future extensibility across multiple external traffic control centers.

#### 9.2.4.5 VMS interface

9.2.4.5.1 The MUTC shall interface with VMS controllers to allow setting messages on the VMS and receiving status updates about the VMS state.

9.2.4.5.2 The interface shall be based on the following protocols based on what each VMS controller is supporting

- NTCIP 1203 protocol
- Modular-Extensible Protocol MEP200802 as described in the Volume E1 Appendix 10 – Modular-Extensible Protocol MEP200802.

9.2.4.5.3 The MUTC shall be able to manage the VMS configuration.

9.2.4.5.4 The users shall be able to set messages on the VMS. Before setting a message, the MUTC will display the message as it should appear on the selected VMS. If the message is cut off or is not displayed properly, the MUTC will not allow it to be set on the VMS.

9.2.4.5.5 When users manually set a message, the user will define the period the message will appear on the VMS. Once the period is over, the MUTC will return to apply other VMS strategies or user requests.

9.2.4.5.6 Messages may consist of one line message or multiple line messages depending on the target VMS.

9.2.4.5.7 The MUTC shall be able to clear messages from the VMS.

9.2.4.5.8 The MUTC shall be able to monitor the status of the VMS. Upon failures the MUTC will create alerts and events based on the severity of the failure.

9.2.4.5.9 The MUTC shall display the VMS and VMS state on the map and allow users to manage the VMS configuration and set messages.

9.2.4.5.10 The MUTC shall include a module to create, edit, and delete predefined messages directory for each VMS.

9.2.4.5.11 Messages shall support Hebrew, English, and Arabic alpha-numeric characters and any combination between the languages. In addition, the message

shall support punctuation and special characters including ' ' , '@' , '#' , '\$' , '%' , '&' , '\*' , '(' , ')' , ':' , ';' , ',' , '.' , '-' , '\_' , '+' , '=', etc.

9.2.4.5.12 Traffic engineers may apply free text messages and a predefined message directory to each VMS.

9.2.4.5.13 Traffic operators shall set a message only from the predefined message directory.

9.2.4.5.14 The MUTC will enforce the MOT guidelines for planning alternating road signs traffic messages as published by the MOT ([link](#)). The MUTC will enforce the guidelines during the definition of each message and before setting a message on a VMS.

9.2.4.5.15 The MUTC will include message priority mechanism to define which message to show on a VMS if multiple messages are requested to set on a VMS.

9.2.4.5.16 The supplier will update the management of change requests for traffic management plans module to include change requests for the predefined message directory of each VMS. See section 4.7.4.

9.2.4.6 Collecting and integrating traffic data from external traffic data sources or a new type of detector.

AHCo may request establishing an interface with a traffic data source (e.g. TomTom) or with a new type of dedicated traffic detector deployed in key locations. The types of detectors/sources AHCo might deploy in the coming years: Radar detectors, Microwave detectors, System based on Bluetooth sensors, etc. The MUTC shall support following:

9.2.4.6.1 Receiving and displaying the status of the detectors includes but is not limited to, location, coverage zone, VC Links, working state, and faults.

9.2.4.6.2 The MUTC shall display the detectors and their status on the map. Each type of detector shall have a unique icon.

9.2.4.6.3 Receiving traffic data and storing it in the database. The traffic data might include, but is not limited to, the volume of traffic, count of road users by type, travel speed, travel times, and occupancy.

9.2.4.6.4 The MUTC shall integrate and use the data collected by the detectors/sources to calculate or to accurate the traffic measurements done by the MUTC as described in section 4.6.2.

9.2.4.6.5 The MUTC shall support interfacing with external detectors and traffic data systems using commonly accepted communication protocols, as required by the specific detector or system, including but not limited to:

- MQTT (publish/subscribe messaging for near real-time data streams)
- SNMP (for device status, health monitoring, and fault reporting)
- NTCIP 1203
- Secure HTTPS REST API (e.g., JSON/XML over HTTPS)
- Other industry-standard or vendor-standard protocols commonly used by traffic detectors and sensing systems.

9.2.4.6.6 The MUTC will include object interface (display) for the new source, allowing users to add, edit properties and remove detectors of the new type. See section 4.7.2.6.

9.2.4.6.7 A complete interface design, including protocol selection, data models, security, error handling, and performance requirements, shall be defined during the design stage of each detector or external system interface and documented in the relevant Interface Control Document (ICD).

9.2.4.6.8 All traffic and detector data gathered by the MUTC from external detectors and systems shall be exported to AHCo's Data Warehouse (DW) and Data Lake, in accordance with the system data management and integration requirements.

9.2.4.7 Implementing an interface with additional video analytics system/module

AHCo may deploy additional video analytics systems and/or modules with which the MUTC may be required to integrate; the specific requirements are set out in Section 4.5.2.8.

#### 9.2.4.8 Implementing an interface with a video management system

AHCo may deploy additional video analytics systems and/or modules with which the MUTC may be required to integrate; the specific requirements are set out in Section 4.5.2.9.

#### 9.2.5 Prediction capabilities

The MUTC shall include the ability to predict traffic flow, traffic metrics and LOS for proactive traffic management and Traffic Incident handling.

9.2.5.1 The modules responsible for generating traffic situation awareness and for calculating the traffic metrics will incorporate the traffic prediction module. Thus, the MUTC will allow the users to simulate future traffic conditions.

9.2.5.2 The DSS modules will incorporate the traffic prediction module for the selection of the best traffic Response Plans.

9.2.5.3 The adaptive module of the SIM will incorporate the traffic prediction module for the selection of the best traffic signaling plan.

9.2.5.4 The traffic prediction module calculations shall be saved in the MUTC database and the relevant products shall be exported to the AHCo DW and Data Lake. This will allow us to analyze the prediction results in comparison with the actual values.

#### 9.2.5.5 Operation modes:

The module will be operated in the following modes:

##### 9.2.5.5.1 Manual operation mode

In this mode, the user will select the area of interest. The system will predict the traffic flow, metrics and the LOS up to 60 minutes ahead. It will be possible to view the predicted traffic situation in dynamic or static views.

##### 9.2.5.5.2 Manual assessment of the impact of possible changes in the LOS requirements or the traffic plan

In this mode, the user will select one or more optional policies and Response Plans to be operated in a specific area and Signalized Intersections. The selection may include metrics thresholds and/or traffic Response Plans from a predefined set and/or changes of parameters in traffic plans. For each selection, the system will predict the traffic flow metrics and the LOS up to 60 minutes ahead. It will be possible to view and compare the predicted results of several options. The results will be displayed in dynamic views and static views.

##### 9.2.5.5.3 Automatic operation:

In this mode, the system automatically predicts the traffic flow, and the LOS several minutes ahead, with emphasis on specific areas of interest. If unusual traffic conditions and degradation of LOS are predicted, it automatically issues an alert to the operator and displays the traffic prediction(s). This mode can be used as input for the DSS module to automatically recommend mitigation actions to minimize LOS degradation.

##### 9.2.5.5.4 Guidelines regarding the logic of the module

The module shall use real-time traffic data as well as historical data, weather forecasts, and other parameters in order to predict the future traffic flow, metrics and LOS in a certain area of interest. As part of the process, the module shall compare actual traffic flow with typical traffic patterns at the same time of day. The Supplier shall state the accuracy of the traffic flow prediction.

##### 9.2.5.6 Prediction of Traffic Incidents

The Traffic Incident Prediction capability shall be designed to identify high-risk areas and times for Traffic Incidents, enabling preventive actions to mitigate their occurrence and impact. It can leverage the simulation module for enhanced predictions. The module operates in two modes: off-line, where users manually analyze specific areas based on selected parameters, and automatic real-time mode, where the system continuously predicts accident-prone areas based on predefined risk thresholds. It utilizes real-time and historical data, including traffic conditions, infrastructure status, roadworks, traffic control systems, and weather forecasts, to enhance accuracy. The output includes high-risk road sections and time frames, with real-time predictions covering up to two hours ahead to support proactive traffic management.

## 9.2.6 Additional traffic metrics

The system shall support the calculation, storage, and visualization of additional traffic metrics to enhance operational insight and performance analysis. These optional metrics include, but are not limited to, the following:

### 9.2.6.1 Queue length

The system shall calculate real-time and historical queue length for each lane, lane group, or movement. The metric may be derived from stop-line detectors, upstream detectors, Bluetooth detectors, or video analytics. Queue length may be provided both in:

- Number of vehicles, and
- estimated physical length (meters).

### 9.2.6.2 Public transportation dwell time

For public transportation vehicles equipped with AVL/GPS or detected via video analytics or Bluetooth detectors, the system shall calculate dwell time at the stop line or designated area. Dwell time may be defined as the total time a public transport vehicle remains stationary within the stop-line zone or intersection influence area, including time due to red signal delays.

## 9.2.7 Integrating 3<sup>rd</sup> party Traffic Management Module (TMM)

The MUTC may be integrated with external TMM which may perform one or more of the following tasks:

9.2.7.1 Traffic Signal Planning: creating and managing traffic signal plans that optimize traffic flow at intersections. This includes developing new signal plans and adjusting existing ones based on real-time traffic conditions.

9.2.7.2 Data Collection and Analysis: collecting raw traffic data from various sensors and analyzing this data to inform decision-making processes. This analysis helps in understanding traffic patterns and identifying congestion.

9.2.7.3 Decision-Making Support: providing decision-making capabilities by evaluating traffic conditions and proposing actions to the MUTC. This includes recommending changes to traffic signal timings or implementing specific traffic Response Plans.

9.2.7.4 Handling Exceptional Situations: addressing exceptional traffic situations, such as accidents or road closures, by suggesting appropriate traffic Response Plans to mitigate disruptions.

9.2.7.5 Creating Action Plans: Generating Response Plans that are added to the traffic management directory within the MUTC. These plans can be executed during regular operations or in response to specific Traffic Incidents.

The TMM will be integrated seamlessly with the MUTC, allowing for the exchange of information and commands. It should be able to receive instructions from the MUTC and provide feedback on its operations which contain results of the above tasks.

9.2.7.6 The expected messages between the MUTC and the TMM will include:

9.2.7.6.1 Traffic Signal Plans: proposed Traffic Light Timing Plans to MUTC for integration into its operational directory. This includes details about signal timings, phases, and any adjustments based on real-time traffic conditions.

9.2.7.6.2 Real-Time Traffic Data: real-time traffic data collected from dedicated sensing devices (e.g., detectors, cameras) to the MUTC. This data may include vehicle counts, speeds, and occupancy rates.

9.2.7.6.3 Performance Metrics: performance metrics related to traffic flow and signal effectiveness, which the MUTC uses to assess the performance of the traffic management strategies in place.

9.2.7.6.4 Action Commands: action commands to the MUTC, such as instructions to implement specific traffic Response Plans or to adjust signal timings based on current traffic conditions.

9.2.7.6.5 Status Updates: status updates regarding its operational state, including any issues or Malfunctions that may affect its performance.

9.2.7.6.6 Feedback and Reports: receive feedback from the MUTC regarding the effectiveness of the implemented plan and may also send reports summarizing

traffic conditions.

9.2.7.6.7 Exception Handling Messages: In cases of exceptional traffic situations (e.g., accidents, road closures), the TMM communicates necessary adjustments or emergency management plans to the MUTC.

9.2.7.6.8 Documentation of Actions: documents of all actions taken and data exchanged with the MUTC, which may include logs of decisions made, changes implemented, and the rationale behind them.

#### 9.2.8 MUTC testing tools

The testing tools will be deployed and implemented on the AHCo non-production environment, as specified in Section 5.1.3.2. AHCo will be responsible for the provision of all computer and communication infrastructures in this environment. The Supplier will provide external simulation applications to allow testing the MUTC interfaces with external systems, Outstation Devices, and data sources. These provided components will be installed in the non-production environment for the SIAT testing and subsequent maintenance.

9.2.8.1 Simulation of each type of Traffic Light Controller.

9.2.8.2 Simulation of each interface with an external system and data source.

9.2.8.3 Simulation of each type of Outstation device like VMS, UPS, etc.

#### 9.2.9 Tablets for AHCo's rangers

The Supplier will provide hardness tablets for the use of AHCo's rangers for connecting to the MUTC. If AHCo orders this workload, it will provide the specifications of the tablets, including the interface connection to the OT Network DC environments and NIMBUS cloud environment, as well as the hardening policy.

#### 9.2.10 Advanced monitoring of UPS devices

9.2.10.1 The MUTC shall have an interface to the UPS devices based on SNMP V3 protocol.

9.2.10.2 The MUTC will have to support different MIB definitions, as each type of UPS device may have a different MIB.

9.2.10.3 The MUTC will include a dedicated user display to show the state of each UPS, including:

9.2.10.3.1 Showing the input lines voltage and frequencies.

9.2.10.3.2 Showing the output voltage and output status.

9.2.10.3.3 Status of Battery – Temperature.

9.2.10.3.4 Status of Battery – status.

9.2.10.3.5 Status of Battery – capacity.

9.2.10.3.6 Status of Battery – battery voltage.

9.2.10.3.7 Status of Battery – battery age.

9.2.10.3.8 Status of Battery – charge level.

9.2.10.3.9 Status of Battery – Time the UPS is working on battery.

9.2.10.3.10 Is the UPS in bypass mode.

#### 9.2.10.4 Anomalies detection

9.2.10.4.1 The MUTC will receive and generate alerts based on the information sent from the UPS like overload alert, battery failure, temperature issues. The exact list of alerts will be defined during the CDR phase.

9.2.10.4.2 In case the input voltage or output levels are not stable for a period of time, the MUTC shall raise an alert. The period of time will be a configurable value by the users.

9.2.10.4.3 If the temperature exceeds a specific threshold, the MUTC shall raise an alert. The period of time will be a configurable value for the users.

9.2.10.5 The performance of the interface with the UPS devices shall be in near real-time.

9.2.10.6 The MUTC will include a window for defining UPS configuration values like thresholds.

9.2.11 VMS message control within Predefined Response Plans

The Predefined Response Plan module shall enable authorized users to define and execute Response Plans that include operational instructions for VMS. This capability shall allow Response Plans to control VMS content dynamically, either through predefined messages or through messages derived from traffic management strategies, as specified below.

9.2.11.1 Message selection from the predefined message library.

9.2.11.2 Message duration configuration - The duration shall be configurable per message and may include fixed time intervals or conditions for automatic termination based on plan execution logic.

9.2.11.3 Message removal and VMS clearing - The system shall support the explicit removal of a VMS message as part of a Response Plan. Upon execution of this action, the VMS shall be cleared and returned to a blank or default state, in accordance with predefined operational rules.

9.2.11.4 Strategy-based message application - The system shall support the application of calculated VMS messages derived from traffic management strategies. In this mode, the message content shall be determined automatically based on strategy outputs, such as traffic conditions, Traffic Events characteristics, or predefined decision rules, and shall be applied to the relevant VMS devices as part of the Response Plan execution.

9.2.12 Additional traffic strategies

9.2.12.1 Estimated travel times strategy.

The system will include a traffic strategy for calculating estimated travel times between two endpoints with a specific route based on the actual traffic data.

9.2.12.1.1 The users will be able to add, edit, and delete routes definitions.

9.2.12.1.2 The route definition will include a name, start point, end point and the links from start and end point.

9.2.12.1.3 The definition will include a VMS on which the calculation time will be displayed.

9.2.12.1.4 The MUTC will automatically update the following information – username created the route, creation date, last username to update the route's definitions, last update date.

9.2.12.1.5 Users will be able to determine if the route is active or not. If active the MUTC will calculate the travel time based on the actual traffic data gathered from the links.

9.2.12.1.6 Users will be able to determine if the estimated travel times strategy is active or not. Only if the strategy is active will the MUTC calculate the travel times.

9.2.12.2 Notifying road users about Traffic Events.

The system will include a traffic strategy for notifying road users about Traffic Events via VMS signs.

9.2.12.2.1 Users shall choose the types and subtypes of Traffic Events they want road users to be notified about, as well as specify the links or signalized intersections where these Traffic Events occur.

9.2.12.2.2 Users will set a message template for each type and subtype. If an Traffic Event with the same type and subtype occurs, and the specific link matches the definition, the MUTC will fill in the message template using the Traffic Event information and display it on the defined VMS.

9.2.12.2.3 Once the Traffic Event is over the MUTC will stop presenting the message about the Traffic Event on the VMS. The MUTC will return apply other VMS strategies.

9.2.12.2.4 Users will be able to determine if the strategy of notifying road users about Traffic Events is active or not. Only if the strategy is active will the MUTC

show messages about Traffic Events to road users.

#### 9.2.13 Waze interface extension

As part of the interface, the MUTC shall automatically notify information about road closures to Waze, particularly for road closures or restrictions managed by AHCo. The interface will be based on the existing Waze Rest API. The MUTC will automatically update Waze in any road closure information change. See section 4.7.3.8 for managing road closures.

#### 9.2.14 Reports and dashboards

##### 9.2.14.1 Small Report

A report characterized by:

9.2.14.1.1 1 primary data source (e.g., Traffic Events table, detector measurements, user activity logs).

9.2.14.1.2 Up to 3 calculated or aggregated metrics.

9.2.14.1.3 Basic aggregations (sum, average, count, min/max) and Simple filters (time range, entity ID, location).

9.2.14.1.4 No more than 1 simple join to a reference or lookup table.

9.2.14.1.5 Single time dimension (e.g., date, shift, hour of day).

9.2.14.1.6 Tabular output with up to 2 basic charts.

##### 9.2.14.2 Medium Report

A report characterized by:

9.2.14.2.1 2–4 related data sources (e.g., timing plans + detectors + metrics).

9.2.14.2.2 4–6 metrics, including derived metrics.

9.2.14.2.3 Aggregations with grouping across multiple dimensions.

9.2.14.2.4 Up to 3 joins, including time-based or entity-based correlations.

9.2.14.2.5 Multiple time dimensions (e.g., date, weekday, hour, month).

9.2.14.2.6 Combination of tables and multiple charts or dashboards.

##### 9.2.14.3 Large Report

A report characterized by:

9.2.14.3.1 5 or more heterogeneous data sources.

9.2.14.3.2 More than 6 metrics, including composite and trend-based indicators.

9.2.14.3.3 Advanced calculations (trend analysis, normalization, percentile analysis).

9.2.14.3.4 Time-series comparisons across periods.

9.2.14.3.5 Complex correlations across entities, time, and geography.

9.2.14.3.6 Multi-level joints (e.g., intersection → movement → phase → metric).

9.2.14.3.7 Cross-period comparison (e.g., YoY, before/after, baseline vs. current).

9.2.14.3.8 Advanced visualizations (time-series dashboards, heatmaps, comparative graphs).

9.2.14.3.9 May require interpretation of traffic management outcomes.

##### 9.2.14.4 Dashboards:

- 9.2.14.4.1 Small dashboard – a focused view with a limited set of KPIs/widgets for a single purpose (e.g., quick status, one corridor/zone, one device group).
- 9.2.14.4.2 Medium dashboard – a multi-widget operational view combining several related indicators, with filtering and drill-down to relevant operational screens.
- 9.2.14.4.3 Large dashboard – a comprehensive situational dashboard integrating multiple domains (operations, events, assets) and supporting multi-level drill-down and cross-filtering.

#### 9.2.14.5 Predefined reports

For each of the predefined reports listed below, AHCo has assigned a size classification of Small (S), Medium (M), or Large (L), in accordance with the report-size definitions set out in Section 9.2.14.1 to 9.2.14.3. The Supplier may challenge this classification; in such case, the Supplier shall state its proposed classification and provide a detailed explanation in the Compliance Table.

- 9.2.14.5.1 Shift report (M) - provides a structured summary of key system activities and traffic conditions that occurred during a specific operational shift. This report will serve as a handover tool between shifts, ensuring continuity in traffic management and situational awareness.
- 9.2.14.5.2 Maintenance report (S) - summary of maintenance-related issues and activities associated with systems and field devices managed by the MUTC.
- 9.2.14.5.3 Bus frequency by bus stop report (M) - The users select which bus stops, bus operators, bus lines, days of the week, and hours of the day the report will be generated. The report will show the frequency of buses by bus line stopping at the bus stop by an hour of the day, and the frequency of total buses stopping at each bus stop at different periods of the day. See Volume E1 Appendix 9 – 9.8 Bus frequency by bus stop report as a draft.
- 9.2.14.5.4 Detector data reports (M) - a detector data report covering aggregated analysis of detector triggering events over selected time periods, analysis of traffic data collected from detectors, and trend analysis, comparisons, and summaries by detector type, location, time period, and aggregation period.
- 9.2.14.5.5 Metrics and performance reports
  - A predefined report for a single metric, including deviations from the norm and deviations from the required policy (S).
  - Reports for each performance metric, the deviations from the norm while incorporating information about the traffic plans that were executed to minimize the deviation (S).

See Volume E1 Appendix 9 – 9.12 Waze LOS report as a draft for the LOS metric report based on information collected from Waze.

- 9.2.14.5.6 Traffic Light Controller reports - Analytical reports related to traffic signal operation and timing plans, including:
  - Faults report – faults report for Outstation Devices, covering the history of faults, the number of faults per device, the probability distribution of fault types, and the total fault duration, with filtering and analysis by an Outstation Device, year, month, and maintenance contractor (M).
  - Detailed List of manual and system-initiated Traffic Light Timing Plan changes that are not as set in the scheduled timing plan. The report will include information about the origin of the change, the reason or cause of the change, the period of change, the original scheduled timing plan and what the actual timing plan was. The report will also include the frequency of use of each Traffic Light Timing Plan in those changes, frequency of changes by hour of day, and frequency of periods of changes. Users may select the year, months, and part of the day, list of Signalized Intersections, and sub-network of traffic lights as the parameters of the report. See Volume E1 Appendix 9 – 9.6 Changes of the active traffic light plan report as a draft (L).
  - A mismatch between the weekly schedule timing plan defined for the Traffic Light Controller in the SIM and the weekly schedule timing plan that exists in the Traffic Light Controller (S).
  - Information on cases where the DSS module didn't find a better timing plan to replace the existing one (S).
  - Frequent recurring replacement of the active Traffic Light Timing Plan which is not according to the schedule. List of Signalized Intersections in which there are frequent recurring replacements of the active Traffic Light Timing Plan which is not according to the schedule. The user will be able to set the threshold of frequency such as more than 5 times in a part of a day, a day, a week, a month, etc. The user will be able to define the range of dates to check (M).

- Green wave report – graphically displays the actual bandwidth across the Signalized Intersections of the green wave against the planned bandwidth (M).
- Traffic Light Timing Plan report which will consolidate various aspects of the Traffic Light Timing Plan – Max green duration by plan and structure, list of changes to the Traffic Light Timing Plan, LOS per movement. See Volume E1 Appendix 9 – 9.1 Traffic Light Timing Plan report for a draft (M).
- Percentage and Frequency of Green Utilization report. The report will display the calculated percentage of green for vehicles by Date range, month, weekday, plan ID, and movement. In addition, it will calculate and display the frequency of green utilization for vehicles. See Volume E1 Appendix 9 – 9.2 Percentage and Frequency of Green Utilization as a draft (M).
- Overview of initiated changes in the active traffic light plan report. The report will compare and summarize the number of initiated changes to the active Traffic Light Timing Plan (manual and system-initiated). Users may select a list of Signalized Intersections, year, month, part of day and the system will calculate the frequency of the initiated changes in total for the selected time frame compared to the previous year. The report will also display the frequency of initiated changes by month for each Signalized Intersection for the selected time frame. See Volume E1 Appendix 9 – 9.4 Initiated changes in the active traffic light plan report as a draft (M).
- List of changes to the traffic light plans report. This report will show an overview of the types of changes made to the traffic light plans including the frequency of each type of change in the traffic light plan, the frequency of type of changes to the weekly schedule, and a summary of changes. Users may select the year, months, range of dates, and list of Signalized Intersections as parameters. See Volume E1 Appendix 9 – 9.5 List of changes to the traffic light plans report as a draft (M).
- Pedestrian green for continuous crossing report. The report will calculate the duration of greens for pedestrians which enables the pedestrians to cross the road without a stop. The report will show the period for crossing for each plan, and the average green by hour of day. The users may select the year, months, day of the week, Signalized Intersection, date, and phase as parameters of the report. See Volume E1 Appendix 9 – 9.7 Pedestrian Green for continuous crossing report as a draft (M).
- Schedule of green wave plans report (S). See Volume E1 Appendix 9 – 9.9 Schedule of Green-Wave plans report as a draft.

9.2.14.5.7 Traffic data report from external systems (M) - comparison between data collected in a certain date range against historical data. The report will allow analysis of data received from external systems and detectors like radar-type detectors, Bluetooth detector systems, video analytic systems, strategic detectors, etc. The report will allow the selection of the type of information for comparison such as traffic volume, travel speed, etc.

- See Volume E1 Appendix 9 – 9.10 Waze raw data of travel duration report as a draft for Travel duration information collected from Waze.
- See Volume E1 Appendix 9 – 9.11 Travel speed by Waze as a draft for Travel speed information collected from Waze.

9.2.14.5.8 Priority reports

- Delay at stop line (M) - Calculating the duration a vehicle with priority waited at the stop line at a Signalized Intersection until the vehicle received a green light. The report will highlight records that are above a certain limit.
- A Transit Signal Priority (TSP) report which will provide when and how often transit vehicles (such as buses or trams) request priority, whether priority was requested, granted, and effective (L). The report will include data such as
  - Priority requested data like time and date of each priority request, vehicle id, direction of travel, which detector was triggered and if supported the type of request (early green, green extension, phase insertion, etc.).
  - Priority grant/denial information which details whether the request was granted, denied or canceled. If denied the report will include a reason for the denial (Example – conflict with another phase, max green reached, coordination constraints, etc.)
  - Details about the signal timing and phase data including amount of green time extended or red time shortened, the impact on cycle length and offset, phase start and end times.

- Traffic impact measures which detail the changes in side-street or pedestrian delay.
- The report will include a visual priority event timeline.
- Operational statistics which will include total number of signal priority requests, granted, and denial - per period, per route, direction, per vehicle id. The Total will be aggregated per hour or part of the day. The report will include the number of times priorities were limited to protect general traffic. The report will include the ability to show and compare the output against another chosen period (M).
- Report on priority detectors faults per period of time for chosen Signalized Intersections (S).

#### 9.2.15 Tiered Personnel Rates

AHCo may use the Bill of Quantities (BoQ) to request additional works from the Supplier, as deemed necessary for the MUTC.

For the design, development, testing, configuration, and installation of new features or system changes within the MUTC environment and any Outstation Devices provided by the Supplier, the Supplier shall provide a cost proposal based on the applicable hourly rates defined in the BoQ, categorized according to four (4) personnel seniority tiers, as detailed herein.

The applicable hourly rates shall be those proposed in Supplier's Price Proposal submitted in the Tender, and shall apply to all services provided under this Section.

The hourly rates shall be applied in accordance with the actual personnel level required for the performance of the relevant tasks.

##### 9.2.15.1 Tier A – Senior / Expert Level Personnel

This tier includes senior and expert personnel with substantial professional experience and proven expertise in system architecture, functional design, traffic management concepts and strategies, and overall technical leadership. Tier A personnel shall be responsible for leading complex technical activities, defining and reviewing solution designs, making key design decisions, and providing professional guidance across the implementation and operation of the system, including:

- Senior Product Manager
- Senior System Engineer / Solution Architect
- Senior Traffic Engineer
- Senior Cyber / Network Engineer (architecture-level tasks)

##### 9.2.15.2 Tier B – Professional / Implementation Level Personnel

This tier includes professional-level personnel responsible for hands-on implementation, development, engineering execution, system configuration, and data analysis activities required for delivery and optimization of the system. Tier B personnel shall perform detailed technical work in accordance with the approved architecture and design, including development, configuration, integration, testing, calibration, data analysis, performance monitoring, and other technical implementation activities, including :

- Software Development Engineer
- System Engineer
- Network or Cyber Engineer (implementation level)
- Traffic Engineer (implementation and calibration activities)
- Data Analyst

##### 9.2.15.3 Tier C – Support / Validation Level Personnel

This tier includes personnel responsible for support, testing, validation, quality assurance, and user experience activities. Tier C personnel shall perform the activities required to verify system quality, usability, and compliance with the applicable requirements, including:

- QA personnel
- UX / UI Designer or Specialist
- Testing and validation personnel

#### 9.2.15.4 Tier D – Field Installation and Modification Personnel for Supplier-Supplied Outstation Devices

This tier includes field personnel responsible for the physical installation, replacement, adjustment, and implementation of changes to Outstation Devices supplied by the Supplier, including any related infrastructure works. Tier D personnel shall also perform the activities required to verify the safe and proper installation of such devices and to ensure compliance with applicable technical, electrical, and safety standards. For pricing purposes, Tier D personnel shall be categorized as follows:

- Field technician / Certified electrician
- Safety equipment operator / General worker

#### 9.2.15.5 General Provisions

The Supplier shall assign personnel levels **proportionate to the task complexity**, avoiding overqualification where not required. AHCo reserves the right to review and approve the proposed personnel tier allocation per task. Hourly rates for each tier shall be fixed in the BoQ and shall apply regardless of the specific job title, provided the scope aligns with the tier definition.

#### 9.2.16 Additional Training and Knowledge Transfer Services

##### 9.2.16.1 General

In addition to the baseline training program defined in Chapter 13 (Training), AHCo may require additional training and knowledge-transfer services during the operational lifecycle of the MUTC system. Such services may be required in order to support onboarding of new personnel, refresher training for existing users, introduction of new system capabilities, professional workshops, or specialized guidance related to the operation, configuration, or advanced use of the MUTC system.

##### 9.2.16.2 Training Day

The Supplier shall provide instructor-led training sessions for AHCo personnel covering operational, administrative, technical, or analytical aspects of the MUTC system.

9.2.16.2.1 A Training Day shall consist of up to eight (8) hours of instructor-led training, excluding reasonable breaks.

9.2.16.2.2 A training day may include preparation and delivery of training materials, system demonstrations, practical exercises, operational scenarios, and professional discussion sessions.

9.2.16.2.3 Training topics may include, among others:

- System operation and workflows
- Traffic Event management procedures
- Traffic plan management and operational configuration
- System administration functions
- Reporting and analytics tools
- System modules, capabilities and operational best practices.

9.2.16.2.4 AHCo may combine several training topics within a single Training Day according to operational needs.

#### 9.2.16.3 Expert Training Hour

The Supplier shall provide specialized professional guidance and targeted training sessions delivered by qualified system experts. Such services may include focused training, advanced configuration guidance, troubleshooting assistance, analytics and reporting tools training, system integration guidance, or workshops addressing specific system capabilities.

9.2.16.3.1 An Expert Training Hour shall consist of one (1) hour of professional services delivered by a qualified expert.

9.2.16.3.2 Expert Training Hours shall be ordered using the professional hourly services mechanism defined in Section 9.2.15. (Hourly Personnel Rates).

9.2.16.3.3 The personnel delivering such services shall possess qualifications and expertise consistent with the key professional roles defined for the project.

#### 9.2.16.4 Training Materials

Training sessions provided under this section shall include preparation and delivery of relevant training materials, presentations, and practical demonstrations as applicable. Training materials produced under this section shall be provided to AHCo for internal use.

#### 9.2.17 Integration test with a Traffic Light Controller

At AHCo's specific request, the Supplier shall participate in an integration test of the MUTC interface with a Traffic Light Controller, including verification of the MUTC's control and management functions in relation to the tested controller. For the purpose of such testing, the Supplier shall connect an instance of the MUTC from the development environment or the testing environment to the relevant Traffic Light Controller. No later than one (1) week after completion of the test session, the Supplier shall submit a detailed report identifying the functions that passed, the functions that failed, and any other relevant findings or observations.

## 10 Migration from the Legacy System to the MUTC

### 10.1 General

- 10.1.1 The section describes a requirement for the Supplier to design, build and implement a migration process of data from the old system (Avivim) into the MUTC. The data includes definitions of Signalized Intersections, Predefined rules for automatic Traffic Light Timing Plan change, and Waze links.
- 10.1.2 The Supplier is responsible to design and implement any changes into the data in order to fit into the data structure of the MUTC.
- 10.1.3 AHCo shall be responsible for managing and resolving matters requiring action, clarification, or cooperation from the old system provider. The Supplier shall not be held liable for delays or impacts arising from the incumbent provider's failure to cooperate, provided that the Supplier has acted in a timely, reasonable, and documented manner.

### 10.2 Connecting to Signalized Intersection

#### 10.2.1 Define all the existing Signalized Intersections

The Supplier is required to define all the existing Signalized Intersections in the MUTC, including all the settings required for the communication definitions, creating the intersection diagram including all the relevant elements of the traffic light (light bulbs, Push Buttons, detectors, phases, etc.), to configure Signalized Intersection's metadata, loading the traffic timing plans into the MUTC, applying weekly schedule and any special schedulers (holidays, weekends, etc.), setting green wave definitions, and sub-networks. The Supplier will then connect each Signalized Intersection to the MUTC and perform an integrity check of the functioning of the intersection.

#### 10.2.2 Predefined Rules

The Supplier is required to copy from the old system to the new system all existing predefined rules for and to implement them in the rule-based Traffic Light Timing Plan changer. The Supplier will check that all rules are set correctly and run if the conditions are met.

#### 10.2.3 Coordination with the old system supplier.

10.2.3.1 The Supplier will coordinate the process of migrating data and take control over each Signalized Intersection from the old system with the old system supplier.

10.2.3.2 The Supplier will coordinate the migrating process with the providers of the networks to the Outstation Devices, and with each Traffic Light Controller maintenance contractor.

#### 10.2.3.3 Planning a timetable for connection with Signalized Intersections.

The Supplier shall prepare and define a timetable for connecting all the existing Signalized Intersections to the MUTC. The timetable will be coordinated with the old system supplier, with the providers of the networks to the Outstation Devices and with each Traffic Light Controller maintenance contractor. The Supplier will present the timetable to AHCo for approval not later than 2 (two) months before the installation phase and adjust the plan according to AHCo instructions.

#### 10.2.4 Quantity of Signalized Intersections to be connected

The number of Signalized Intersections is set out in Table 17 - forecasted users and traffic management capacities. This number is provided for planning purposes only, is not binding, and shall be finally determined during the PDR phase. The anticipated distribution of the Signalized Intersections among the municipalities is set out in Volume E1 Appendix 1 – list of municipalities.

#### 10.2.5 Migration Breakdown by Versions

##### 10.2.5.1 Block 1 (Version 1)

10.2.5.1.1 Migration and integration with forty percent (40%) of MANTAM Hamifratz existing Signalized Intersections will be part of the installation and delivery stage of Block 1 (Version 1), prior to the beginning of the trial run of Block 1 (Version 1).

- 10.2.5.1.2 Migration and integration with the rest of the MANTAM Hamifratz existing Signalized Intersections required for Block 1, shall be performed during the trial run of Block 1 (Version 1) and must be completed by the end of Block 1 (Version 1) trial run. Completion of the Signalized Intersections installation and integration will be part of the approval of the trial-run milestone.
- 10.2.5.1.3 The migration will include the migrating of the predefined rules and Waze link of MANTAM Hamifratz.
- 10.2.5.2 Block 1 (Version 2)
  - 10.2.5.2.1 Migration and integration with forty percent (40%) of MANTAM Dan's existing Signalized Intersections will be part of the installation and delivery stage of Block 1 (Version 1), prior to the beginning of the trial run of Block 1 (Version 1).
  - 10.2.5.2.2 Migration and integration with the rest of the MANTAM Dan's existing Signalized Intersections Signalized Intersections required for Block 1, shall be performed during the trial run of Block 1 (Version 2) and must be completed by the end of Block 1 (Version 2) trial run. Completion of the Signalized Intersections installation and integration will be part of the approval of the trial-run milestone.
  - 10.2.5.2.3 The migration will include the migrating of the predefined rules and Waze link of MANTAM Dan. See section 10 for detailed requirements.
- 10.2.5.3 The migration and the connection of the Signalized Intersections cover two system sites, MANTAM Dan and MANTAM Hamifratz, and may be performed in two separate implementation periods, in accordance with the approved project timeline.

### **10.3 Waze Links**

The Supplier is required to copy from the old system to the new system all existing Waze links definitions and other traffic detectors definitions for the collection of traffic data. The Supplier will connect each link and detector to the new System. The Supplier will check that the links and traffic sensors are providing the required data and that the information and metrics are collected and generated correctly.

### **10.4 Automated Data Migration**

The Supplier shall develop automated processes to extract data and configurations from the old system, transform them as required, and load them into the MUTC, in order to minimize data loss and data errors. The Supplier may assume that a digital version of the old system's data will be made available.

# 11 Project management

## 11.1 General

The Supplier shall establish, maintain, and manage an effective project organization for the successful execution of the MUTC project throughout all its phases, including design, development, integration, testing, installation, trial run, delivery, handover, and support during the development period.

### 11.1.1 Project Management Team.

The Supplier shall build a dedicated project team, which will lead the design, development, integration testing, and the trial run of all the MUTC ordered Blocks, Versions, and other deliverables required in this Tender. The proposed MUTC project team personnel and any changes within the team personnel, including (but not limited to), role changes, job scope, new members, member dismissal and such, must be approved in advance by AHCo. The project team shall include a project management team with at least the following members for the specified timeline as detailed in the table below.

Position	Role	Time for submission of the candidate to AHCo	Commencement timeline	Required on-site physical presence
Project Manager	Manager of the MUTC project.	within 14 days of receiving a winning notification	ARO	During major milestone deliveries, installation activities, SAT execution, and in addition shall attend project management meetings at least one (1) day per month and at any other time upon AHCo's request.
Chief System Engineer	Leads the execution of system engineering tasks starting from the requirement assessment until the final system testing.	within 14 days of receiving a winning notification	ARO	During all MUTC major reviews milestones (SRR/SDR/PDR /CDR/TRR)
System Architect	Leads the design of the system architecture – software, infrastructures, interfaces, etc.	ARO	According to the Supplier's need	Participation on an on-call (online) basis during all MUTC Design Reviews.
Traffic Engineer	Leads the design of the traffic management functionality implementation.	within 14 days of receiving a winning notification	According to the Supplier's need	Participation on an on-call (online) basis during all MUTC major Design Reviews (SRR / PDR / CDR/TRR)
Data Engineer	Leads the design of data collection and dissemination, data aggregation, and DBA.	ARO	According to the Supplier's need	Not required
Data Analyst	Leads the design of data analytics which includes setting data models, data fusion, data cleaning, setting metrics logics, algorithms and thresholds.	ARO	According to the Supplier's need	Participation on an on-call (online) basis during all MUTC major Design review milestones (SRR / PDR/ CDR / TRR)
Cyber Architect	Leads the design and implementation of the	ARO + 1	According to the Supplier's	Participation on an on-call (online) basis during all MUTC major

	solutions for security, cyber and privacy aspects of the project.		need	Design Reviews (SRR / PDR / CDR / TRR)
Maintenance Manager	Leads the support & maintenance teams from the first system deployment* (Block 1 – Version 1) till the end of the Maintenance Period. * Prior to trial-run	ARO + 2	According to the Supplier's need (No later than Block 1 – Version 1 deployment)	Constant presence in Israel until the end of the Maintenance Period.

*Table 21 – Project management team*

During the entire engagement period, each member of the project management team (as detailed in the table above) shall allocate the necessary amount of time in order to comply with the Supplier's obligations detailed in this document and the Agreement. The Supplier will submit its proposal for such time allocation to AHCo's approval at the kick-off meeting (however, for the avoidance of doubt such approval shall not derogate from the Supplier's obligations to fulfill all undertakings under this document and the Agreement, including allocation of additional time by the project management team and/or the appointment of additional employees as necessary).

Required experience, for the members of the project management team (minimum requirements):

With respect to each member of the above management team, the reference below to "five (5) years of experience" shall mean at least 5 years of experience as an active participant in the specific required capacity, in one or more projects of the following scale:

- The project must include the development of a major command and control information system
- The system has at least 50 users
- The system has at least 10 interfaces to external systems
- The budget of the project (only the main software of the system, excluding the costs of its endpoints and hardware) is above 10 million New Israeli Shekels (NIS).

All degrees listed below shall be from Israeli academic institutions recognized by the Israeli Council for Higher Education, or from reputable academic institutions outside Israel acceptable to AHCo (at its sole discretion).

All members of the project management team shall be able to communicate effectively in English, both verbally and in writing.

If the Supplier submits a candidate who does not meet the minimum requirements as outlined above and below, AHCo may request that the candidate be replaced with one who does meet the minimum requirements.

- 11.1.1.1 **Project Manager** – (1) B.Sc. degree or Computer Science degree. (2) Five (5) years of experience in the management of traffic command and control (C2) project, in which at least three (3) years of experience in implementing urban traffic control systems, which includes management of Signalized Intersections.
- 11.1.1.2 **Chief System Engineer** – (1) B.Sc. degree in Electronic Engineering, Software Engineering, or Computer Engineering, or a degree in Computer Science or Information Systems. (2) Five (5) years of experience as a system engineer. (3) At least 2 years of experience in designing and implementing Urban Traffic Control Systems, which includes the management of Signalized Intersections. Experience with ITS systems will be considered as an advantage.
- 11.1.1.3 **Systems Architect** – (1) B.Sc. degree in Computer Engineering, Software Engineering or degree in Computer Science. (2) Five (5) years of experience in the development of complex, multi-layer, information systems. Wide knowledge of cloud computing, open architecture, servers, networks, security, etc. Knowledge of Traffic control, ITS, etc. will be considered as an advantage.

- 11.1.1.4 **Traffic Engineer** – (1) B.Sc. degree in Civil Engineering or Transportation Engineering. (2) Five (5) years of experience in defining traffic management requirements for urban traffic management systems, which includes management of Signalized Intersections. (2) At least three (3) years of experience in designing Signalized Intersections.
- 11.1.1.5 **Data Engineer** – (1) B.Sc. degree in Computer Engineering, Software Engineering, or Computer Science. (2) Five (5) years of experience in complex, multi-layered, information systems. (3) Wide knowledge and experience in Databases, Big Data, Machine Learning, Artificial Intelligence, Operating systems, performances, networks, security, etc.
- 11.1.1.6 **Data Analyst** – (1) B.Sc. degree in Computer Science, Data Science, Information Technology, Mathematics or Statistics. (2) Five (5) years of experience as a data analyst or data scientist in an organization, in managing databases, setting data visualization, and performing data analytics offline and in real-time. (3) Wide knowledge and experience in analytic tools – Power BI, Tableau, ClickView – and programming languages – SQL, and Python.
- 11.1.1.7 **Cyber Architect** – (1) B.Sc. degree in Computer Engineering or Computer Science or Information Technology. (2) Five (5) years as CISO in an organization, managing information systems Security, Cyber, and Privacy. (3) Wide knowledge and experience in managing configured, and implementing tools, and know-how in the area of Cyber Security and Privacy. (4) Experience in writing procedures and leading processes in organizations for implementing information security, conducting surveys and complying with security regulations. (5) Experience in building protection circles for a large organization for all communication channels. (6) Wide knowledge of communication networks, servers and end stations.
- 11.1.1.8 **Maintenance Manager** – (1) B.Sc. degree in Computer Engineering, Computer Science, Information Technology, Industrial Engineering, or other related field, with a specialization relevant to IT and software systems. (2) Five (5) years of experience in support & maintenance operations (3) Two (2) years of experience in customer-facing roles in projects with similar scale. Knowledge in traffic control, ITS, etc. will be considered as an advantage. (4) Hebrew-speaking person, as he will serve as the point of contact between the AHCo maintenance staff and the Supplier maintenance center and supervise any notified Maintenance Event.

From the delivery of Version 1 onward, the Maintenance Manager shall act as the in-country focal point of the project, and shall maintain full awareness of the project status, including the status of delivered capabilities, open issues, design decisions, operational gaps, and pending implementation items, and shall maintain an organized record of design misalignments, lessons learned, and identified needs to be addressed in future Versions.

#### 11.1.2 Project Development Team

The Supplier shall characterize all additional members of the development team, including developers, a UX/UI expert, DBA staff, instructor, maintenance support staff, etc., in addition to the project management team. The Supplier shall specify the name, profession, education, and experience of each member. The submission of the project development personnel details will occur prior to his participation in the design, development, testing, maintenance and operation support stage.

#### 11.1.3 Project Schedule Management.

- 11.1.3.1 The Supplier shall use a formal, 'groupware' (teamwork) tool to conduct the management process and coordinate all relevant participants (including AHCo relevant staff).
- 11.1.3.2 The Supplier should use a planning tool such as MS-Project (or similar), or Monday tool (or similar), to manage the project by display of tasks, milestones, teams, individuals, sub-contractors, allocation, critical path, warning for delays, etc. The data on the tool should be updated on a regular basis. A plan formal copy snapshot should be produced monthly.

#### 11.1.4 Communication Methodology

- 11.1.4.1 All meeting protocols should be documented and sent over to all relevant participants.
- 11.1.4.2 Other necessary project updates should be made via emails and WhatsApp messages.
- 11.1.4.3 A shared directory (shared storage space) will be organized for the use of all relevant participants.
- 11.1.4.4 A 'groupware' tool like Monday (or similar), SLACK and/or JIRA shall be used for communication tasks status and allocation.

#### 11.1.5 Progress Meetings and Reviews

- 11.1.5.1 Program Kick-off Meeting.

Within 14 (fourteen) Business Days from ARO a kick-off meeting with key managers and professionals from both parties will take place. At the kick-off meeting, the Supplier shall submit a baseline implementation schedule aligned with the spiral development methodology for Block 1, including the planned dates for each Design Review, test cycle, installation activity, trial run, and delivery milestone for Version 1, Version 2, and Version 3. The baseline schedule shall comply with the maximum delivery times defined in this SOW.

#### 11.1.5.2 Progress Meetings and Reviews\ Program Management Reviews.

As the minimum, 2 (two) types of groups should meet periodically, until the termination of the Agreement:

11.1.5.2.1 The project steering committee will meet on a quarterly basis and will include at least the Supplier's Project Manager and the AHCo project manager. Additional members will participate based on the relevant issues.

11.1.5.2.2 The project management team shall meet once a month and shall include the Supplier's management team members, the AHCo project manager, and any additional participants required for the matters to be discussed. AHCo may determine that certain participants are not required for a specific meeting and may excuse their attendance accordingly. If there are no relevant matters requiring discussion, AHCo may cancel or postpone the meeting.

#### 11.1.5.3 Program Design Reviews.

11.1.5.3.1 The Supplier shall conduct all the required Design Reviews as detailed in Sections 11.5 to 11.9.

11.1.5.3.2 The guidelines and the minimum requirements for each Design Review are detailed in this document from Sections 11.5 to 11.9.

#### 11.1.5.4 Test Readiness Reviews (TRRs) and Test Summary Report Reviews

11.1.5.4.1 The Supplier shall conduct TRRs before the beginning of each MUTC Block and Version test cycle, each Block and its Version cycle includes the SIAT and SAT as detailed in Section 12.2. The guidelines and the minimum requirements for each TRR are detailed in this document in Section 12.1.

11.1.5.4.2 The Supplier shall conduct a test summary report review after the end of the tests cycle of each MUTC Block's Version.

#### 11.1.5.5 Other program reviews and status meetings

11.1.5.5.1 Design Reviews and additional status meetings will be conducted as part of the management team meetings (see Section 11.1.5.2). The following are mandatory design meetings.

11.1.5.5.2 A provision review will be held at the end of each Version's FAT to summarize its results and finalize required enhancements and modifications.

11.1.5.5.3 Installation Readiness Review shall be conducted before the installation of each MUTC Block and Version.

#### 11.1.6 Project personnel changes

11.1.6.1 Project management team member changes may be performed by the Supplier only due to reasons uncontrolled by the Supplier (such as employee resignation, or sickness).

11.1.6.2 Any other reason for any replacement in the management team members requires AHCo approval in advance and may cause penalties as described in the liquidated damages table (chapter 14).

11.1.6.3 Any project team member replacement request must include the proposed replacement candidate's CV and his compliance with the requests for the specific role as outlined in this Tender. The timeline and the handover procedure between the two shall be approved by AHCo. Only once the replacement has been approved by AHCo, the Supplier may commence the replacement process.

11.1.6.4 AHCo in its sole discretion has the right to request a replacement of any one of the project's team members (including a management team member) at any stage of the project. The Supplier must comply with the request and shall propose to AHCo new candidates. For each suggested candidate, the Supplier shall provide the candidate's CVs \ background, suggested timeline for the replacement and the handover procedure, NLT 1 (one) month of the replacement request. Once approved by AHCo, the Supplier may commence the replacement process.

11.1.6.5 To avoid any doubt, any replacement of one of the MUTC project's management team members or other MUTC project team members is subject to AHCo's approval.

## 11.2 Development methodology

The Project shall be executed using a spiral development methodology. The MUTC development and delivery shall be divided into two primary Blocks. Block 1 shall be delivered in three sequential Versions, as further detailed below.

#### 11.2.1 Block 1

Comprises the core functional requirements. It shall be delivered in three distinct versions. The exact distribution of the contents between the Versions shall be defined and refined during the design process, beginning at the SRR and SDR and subject to AHCo approval. The following describes the goals of each version.

##### 11.2.1.1 Version 1:

11.2.1.1.1 Based on the Supplier’s Off-the-Shelf (OTS) system with minimal essential development.

11.2.1.1.2 Deployment is limited to MANTAM Hamifratz

11.2.1.1.3 Connecting to 3 types of Traffic Light Controllers – Actros, EC2, and Flownode.

11.2.1.1.4 Support for prioritization of public transportation of Metronit BRT and Nofit light rail.

11.2.1.1.5 Migrating the data covering MANTAM a HaMifratz from the old System to the MUTC.

11.2.1.1.6 POC of Centralized Adaptive Signalized Intersections.

11.2.1.1.7 Deployment on the OT network of AHCo.

Section	Description
4.2	Multi-site support
4.3.1	Traffic entities
4.3.2	Traffic definitions
4.5.2.1	Interfaces – general
4.5.2.2	Interface management
4.5.2.4	SIM interfaces with Traffic Light Controllers (interfaces with Traffic Light Controllers of the HaMifratz – Menorah + Wiemazor)
4.5.2.5	Road users' application gateway - Waze
4.5.2.10	Maintenance and Logistic Support system gateway
4.5.2.11	Google Traffic data interface
4.5.2.11	Data Dissemination Services Module
4.5.4	Geographic Information System (GIS) Services
4.5.5	Database
4.5.6	System audit
4.5.7	Data localization
4.6.2.1-4.6.2.17	Traffic metrics and Level of Service (LOS) calculation
4.6.3	Traffic Events, anomalies, and exceptions detection
4.6.4	Decision Support Service module
4.6.5	Built-in Reports
4.7.2	User display (The first Version shall be based on the existing user interface provided under the basic license, with the implementation of the basic modifications required to meet the requirements of Version 1).
4.7.3.1-4.7.3.5	Traffic Events management (Based on the existing Traffic Events management module provided under the basic license).
4.8.2	Traffic Light Timing Plans & detectors plans parameters definitions
4.8.3	Signalized Intersection configuration and lifecycle management
4.8.4	Managing Directory of Traffic Light Timing Plans

4.8.5	Traffic Light Weekly Schedule Management for a Signalized Intersection
4.8.6.1-4.8.6.19 4.8.6.24-4.8.6.25 4.8.6.27-4.8.6.30 4.8.6.32-4.8.6.43 4.8.6.44.1-4.8.6.44.4 4.8.6.45 4.8.6.46.1-4.8.6.46.2 4.8.6.47 4.8.6.48.1-4.8.6.48.2 4.8.6.49-4.8.6.51	Monitoring and controlling a Signalized Intersection
4.8.7	Sub-Networks of Signalized Intersections
4.8.8	Double Signalized Intersections
4.8.9.1-4.8.9.13 4.8.9.15-4.8.9.16	Green waves
4.8.12	Traffic management modes
4.8.13	Hierarchy of traffic management modes
4.8.14	Apply actions to groups of Signalized Intersections
4.8.16	Rule Based Traffic Light Timing Plan Changer module (Based on the existing tools provided under the basic license)
4.8.17	Users' permissions regarding the SIM module
4.8.18	Priority module – Activation type A to manage Metronit BRT and Nofit light rail.
4.8.19	Centralized adaptive traffic management module (Applied for 15 Signalized Intersections)
4.8.20.2	Monitoring VPS signs connected to the Traffic Light Controller
5.1-5.8	System Architecture
10	Migration from the Legacy System to the MUTC (Specific contents): Preparing and connecting MANTAM HaMifratz - Copy data from Avivim (Waze, Rules), Defining and connecting to all Signalized Intersections that exist in MANTAM HaMifratz.

*Table 22 - Block 1 Version 1 functionality*

- 11.2.1.2 Version 2: Full deployment to both MANTAM centers (Hamifratz and Dan), incorporating initial custom developments as described in the SOW.
- 11.2.1.2.1 Expanding the Supplier's Off-the-Shelf (OTS) system to include the functionality as described in the SOW.
- 11.2.1.2.2 Connecting to three (3) types of Traffic Light Controllers – Actros, EC2, and Flownode.
- 11.2.1.2.3 Supplying interfaces to external traffic management systems like Sidera
- 11.2.1.2.4 Migrating the data covering MANTAM DAN from the old System to the MUTC.
- 11.2.1.2.5 Deployment of MANTAM DAN and upgrading the version of MANTAM Hamifratz.

Section	Description
4.5.2.3	Interfaces C2C protocols
4.5.2.4	SIM interface gateway (Completing the implementing and integration interfaces with Traffic Light Controllers of the Dan – R.S + IPI)
4.5.2.6	HTMS Interface gateway
4.7.2	User display and control module
4.7.3.1- 4.7.3.5	Traffic Events management module

4.8.10	Configurations
4.8.11	Sites
4.8.12	Traffic management modes
4.8.13	Hierarchy of traffic management modes
4.8.14	Apply actions to groups of Signalized Intersections
4.8.15	Predefined Response Plans
4.8.16	Rule Based Traffic Light Timing Plan Changer module
10	Migration from the Legacy System to the MUTC (Specific contents): Preparing and connecting MANTAM Dan - Copy data from Avivim (Waze, Rules), Defining and connecting to all Signalized Intersections that exist in MANTAM Dan.

*Table 23 - Block 1 Version 2 functionality*

11.2.1.3 Version 3: Final deployment of all Block 1 capabilities to both MANTAM centers.

11.2.1.3.1 Applying advance functionalities

11.2.1.3.2 Adding new metrics

11.2.1.3.3 Implementing new interfaces with video management system, video analytic system

11.2.1.3.4 Upgrading the version of MANTAM Hamifratz and MANTAM Dan.

Section	Description
4.5.2.2.2	Interfaces management (Supporting reliability level definition to each type of source of information)
4.5.2.7	Public transportation authority systems gateway
4.5.2.8	Video analytics module gateway
4.5.2.9	Video management system gateway
4.6.2.19	Additional traffic metrics
4.7.3.6	Traffic Events management module extensions
4.7.3.7	CCTV automatically displays
4.7.3.8	Managing road closures
4.7.4	Management of change requests for traffic management plans
4.8.6.20– 4.8.6.23 4.8.6.26 4.8.6.31 4.8.6.44.5-4.8.6.44.6 4.8.6.46.3-4.8.6.46.4 4.8.6.48.3-4.8.6.48.4 4.8.6.52	Monitoring and controlling a Signalized Intersection (Advanced monitoring and controlling options).
4.8.20.1	Adjust and tune the Green-Wave offset parameters visually

*Table 24 - Block 1 Version 3 functionality*

11.2.2 Block 2

Block 2 of the MUTC shall include only the set of capabilities explicitly ordered by AHCo from among the content listed in Chapter 8.

11.2.3 Mitigating development risks

To mitigate development risks related to the system's UI/UX and the implementation of operational processes and workflows, the Supplier shall deliver a beta version of each Block's Version for the purposes of FAT prior to its final implementation.

- 11.2.3.1 The FAT of each Block's Versions will include UI/UX and workflow testing of the beta version to assess system usability. These tests will be conducted with AHCo involvement (see details in Section 12.2.1).
- 11.2.3.2 The FAT Summary Report and any other feedback regarding the UX and the system workflow implementation following the above tests will be discussed in a dedicated review meeting (Provision Review) to finalize the required modifications for the operational version (of each system Block's Version).

### **11.3 Project Management Plan**

#### 11.3.1 CDRLs and SDRLs

- 11.3.1.1 The Supplier shall manage a full, continuous Project Management Plan (PMP).
- 11.3.1.2 The Supplier shall supply the required formal CDRLs (Contract Data Requirements Lists) for each project delivery.
- 11.3.1.3 In case of using a sub-contractor in the project, Subcontract Data Requirements Lists (SDRLs) should be delivered.

#### 11.3.2 Quality Management Plan

- 11.3.2.1 The Supplier will prepare a Quality Management Plan ("QMP"), which will serve as the basis for quality management and will address the quality assurance and quality control throughout the system's lifecycle - for all project deliverables and processes, also defining who is responsible for what.
- 11.3.2.2 The QMP shall encompass all phases and frameworks of the project, including:
  - 11.3.2.2.1 Planning and design phases.
  - 11.3.2.2.2 Development, installation, configuration and integration.
  - 11.3.2.2.3 System testing
  - 11.3.2.2.4 ILS (Integrated Logistic Support).
  - 11.3.2.2.5 Trial run and handover.
  - 11.3.2.2.6 Operation and maintenance support during the Warranty and Maintenance Periods.
- 11.3.2.3 The objectives of the Supplier QMP will include at least the following:
  - 11.3.2.3.1 Ensuring compliance with AHCo requirements
  - 11.3.2.3.2 Ensuring compliance with professional standards, legal requirements and other relevant regulations.
  - 11.3.2.3.3 Ensuring compliance of deliverables with the approved system design
  - 11.3.2.3.4 Ensuring compliance with approved installation, configuration and integration instructions and procedures.
  - 11.3.2.3.5 Documentation compliance.
  - 11.3.2.3.6 Quality assurance and quality control of subcontractors.
  - 11.3.2.3.7 Coordination and approval processes with AHCo and with any other authority relevant to the project.
  - 11.3.2.3.8 Control of implementation of approved changes, adaptations and exceptions.
- 11.3.2.4 Throughout the project's lifecycle, the Supplier will fully comply with the quality requirements, as specified by ISO 9001: 2015.
- 11.3.2.5 The QMP will be developed according to standard procedures and include at least the following topics:
  - 11.3.2.5.1 Objectives of the MUTC.
  - 11.3.2.5.2 Description of the MUTC and its components.
  - 11.3.2.5.3 General description of the QMP principles, methodology, and key processes.

- 11.3.2.5.4 Tasks and deliverables by the Supplier at all stages of the life cycle of the MUTC.
- 11.3.2.5.5 Gantt of quality control activities integrated within the project Gantt.
- 11.3.2.5.6 Quality assurance and control procedures for each stage throughout the system's lifecycle – for all the parties which will take part in each stage, including employees, subcontractors, and other suppliers.
- 11.3.2.5.7 Topics, deliverables and processes which require the receipt of approval from AHCo at each stage and the procedure for receiving AHCo approval.
- 11.3.2.5.8 The procedures and system for collecting, controlling, and processing data required for the calculation and regular updating of 'Quality indices'.
- 11.3.2.5.9 The organizational structure of the quality control team.
- 11.3.2.5.10 Definition of quality assurance and control roles at the various stages of the project.
- 11.3.2.5.11 Management and control methods of change procedures, configuration updates and releases.
- 11.3.2.5.12 Monitoring updates and versions of documents.
- 11.3.2.5.13 Data transfer and all support procedures at the end of the Period of Engagement.
- 11.3.2.6 The Supplier shall submit the QMP for the approval of AHCo. The initial QMP will be submitted at the SRR and will serve as a basis methodology for quality activity up to PDR. At the PDR, the Supplier will present a full and final QMP.
- 11.3.2.7 The Supplier will submit quarterly reports, to update AHCo regarding the QMP implementation and results.
- 11.3.2.8 In the event of a failure to meet quality goals, the report will include an analysis of the causes and the status of corrective actions that will be taken / already taken.

## **11.4 Requirements management and traceability**

### **11.4.1 Proposed System Compliance Table**

The Supplier shall submit in its Proposal to the Tender the 'Proposed System Compliance Table' (Volume C of the Tender documents). Such a document does not include all the requirements in the SOW.

### **11.4.2 Modifications to the submitted Compliance**

Modifications to the submitted Compliance Table require specific approval by AHCo (requests may be submitted during the clarifications stage of the Tender).

## **11.5 Design stages and reviews**

### **11.5.1 General**

The Supplier will be responsible for the design of the MUTC, its components, and interfaces. The design phase will be carried out in accordance with the guidelines set out below.

### **11.5.2 Reviews**

The reviews shall be conducted in Israel and will be executed subject to AHCo pre-approval of the required documents, to be submitted in advance.

### **11.5.3 Schedule for the design stages:**

The design phase shall comprise the following stages: SRR, SDR, PDR, and CDR. The Supplier shall conduct all required Design Reviews for Block 1 and for any additional Block initiated under the Agreement. For Block 1, the Supplier may propose joint conduct of review activities where efficient and appropriate, subject to AHCo approval; however, the PDR and CDR shall be conducted separately for each Version of Block 1. SRR and SDR may be conducted jointly for more than one Version, subject to AHCo approval and provided that the submitted documentation clearly identifies the content relevant to each Version.

The following tables describe the documents and activities associated with the design reviews.

(D.R. stands for = Design Review)

Design stage	Contents	D.R at the end of phase	Type of document at the end of the stage
SRR stage	as detailed in section 11.6	SRR	Requirements analysis document
SDR stage	as detailed in section 11.7	SDR	Concept of system, implementation, and operation + updated project plan
PDR stage	as detailed in section 11.8	PDR	Initial design plan
CDR stage	as detailed in section 11.9	CDR	Detailed design plan

*Table 25 - Schedule for the design stages documents*

#### 11.5.3.1 Schedule for conducting the various reviews:

Stage Activity	calendar days R.D = Review Date
D.R. documents to be presented at the D.R.	R.D (- 14) for SRR and SDR R.D (- 21) for PDR and CDR
Feedback regarding the documents and approval by AHCo	R.D (- 7)
Date of completion of the review (review may take several days)	R.D (1 - n days) duration according to the scope of the review. To be proposed by the Supplier for approval by AHCo.
Submission of revised documents following the R.D	R.D (+ 7) for SRR and SDR R.D (+ 14) for PDR and CDR
Re-examination of the documents by AHCo and granting final approval	R.D (+ 14) for SRR and SDR R.D (+ 28) for PDR and CDR

*Table 26 - Schedule for the stages accompanying the design reviews*

#### 11.5.4 General principles for conducting the Design Reviews:

- 11.5.4.1 The review will be conducted at an AHCo site unless otherwise approved by AHCo at least 7 days before the date of the review. The Supplier must facilitate 'remote' participation for personnel who are not required to be physically present at the review.
- 11.5.4.2 Prior to each review, the Supplier shall prepare and submit "review documents" for AHCo's approval, containing materials to be presented at the meeting and a detailed schedule for the contents of the review.
- 11.5.4.3 The review will cover all the required topics and will start with the system-level topics and then the presentation of specific components of the MUTC and other topics.
- 11.5.4.4 The Supplier will submit a timetable for conducting the review for the approval of AHCo, taking into account the required duration of each review for presentation and discussion. If the proposed schedule for the review is too 'loaded', AHCo will instruct the Supplier to broaden the timetable, in order to allocate adequate time for the required topics.
- 11.5.4.5 If the documents for the review are not submitted in accordance with the requirements, AHCo may require the Supplier to re-submit all \ part of the documents with required modifications and corrections, and the review dates will be rescheduled accordingly if required by AHCo.
- 11.5.4.6 The review document will be updated at the end of the review meeting (according to the discussions and feedback) and will be submitted in its updated form to AHCo, together with a summary of the meeting which includes the action items and the issues to be addressed.
- 11.5.4.7 If completion of the review is required, the completion will be made within thirty (30) days from the date of the review, without compromising the overall schedule of the design stage or the schedule of the entire project.
- 11.5.4.8 The completion of the Design Review must be approved by AHCo.

11.5.4.9 At the end of the design phase for each system Version, and after the design is approved by AHCo, the final design document will be defined as "Approved Design".

## **11.6 SRR - System Requirements Review**

### **11.6.1 SRR preparation**

Prior to the review, the Supplier will prepare and submit for AHCo approval the survey document, presenting the following topics:

11.6.1.1 Presentation of the Supplier's understanding of the overall requirements of the MUTC.

11.6.1.2 Any questions, clarification and other needs the Supplier requests from AHCo.

11.6.1.3 The Supplier's organizational structure chart for the project, the main functionaries and subcontractors, in accordance with section 11.1.1 above. The chart will include C.Vs, for all personnel designated to take part in the project.

11.6.1.4 A detailed project plan.

11.6.1.5 Initial project plan for each system Block and Version, according to the requirements in section 11.5 above. The minimum level of detail required at this stage is for each sub-stage of the project.

11.6.1.6 The MUTC Product Tree and WBS (Work Breakdown Structure).

11.6.1.7 Initial quality assurance plan which will serve as a basis methodology for quality activity up to PDR (at PDR, the Supplier will present a full and final quality plan).

11.6.1.8 Risk management methodology and preliminary risk report, prepared according to the standard methodology of risk analysis, including the actions to mitigate the risk (risks & mitigations).

11.6.1.9 A tool for managing requirements. The Supplier shall map out all the requirements in this document and put them into the requirements management tool, as a preparatory step. AHCo representatives will have (read-only) access to the tool and data.

11.6.1.10 Requirements mapping - the requirements will be identical to the contents of the requirements management tool, via a response table (VCRM - Verification Cross-reference Matrix) which also includes V & V columns (to prove ability/response, how to prove and verify the fulfillment of each requirement).

11.6.1.11 Project management and monitoring tool: tasks, decisions, responsible party for execution, sub-contractors (if any), due date, actual completion date.

11.6.1.12 Engineering change procedure for the MUTC - the process of creating, reviewing, and approving engineering change requests (ECRs) and engineering change orders (ECOs). It is clarified that in any case, the approval of any change will be subject to the provisions of the Agreement.

## **11.7 SDR – System Design Review**

### **11.7.1 Prior to the review**

Before the review, the Supplier will prepare and submit the survey document and presentation for AHCo approval: The document and presentation will include at least the following topics:

11.7.1.1 At this stage, the Supplier will include a reference to each requirement in the Tender or to requirements agreed upon during the SRR.

11.7.1.2 The MUTC concept and a conceptual High-Level Design (HLD) of the system including design considerations. The HLD shall include the core components, interfaces, and infrastructures including GFE and 3<sup>rd</sup> party components to be integrated.

11.7.1.3 Aspects related to user interface and user experience (UX).

11.7.1.4 Updated product tree and WBS.

- 11.7.1.5 Up-to-date project Gantt (according to the requirements herein), including required resources, critical paths and division of responsibilities, reference to contents according to project stages defined in this document, reference to transition between stages, and addition of sections and capabilities.
- 11.7.1.6 Comprehensive management plan.
- 11.7.1.7 Addressing regulatory aspects and compliance with standards.
- 11.7.1.8 All the aspects related to the integration of GFE in the project.
- 11.7.1.9 Principles of MUTC's cyber security architecture, means and related procedures.
- 11.7.1.10 Model, tools, and plan for reliability and availability of the MUTC.
- 11.7.1.11 Master plan for the MUTC QA and QC for the development stages and implementation stages.
- 11.7.1.12 The main plan for the MUTC maintenance phase – supporting organization, procedures and a basic plan in the field of ILS (Integrated Logistic Support).
- 11.7.1.13 An initial program for testing and experiments including an initial Gantt.
- 11.7.1.14 The status of the list of open topics, action items and tasks from the SRR.
- 11.7.1.15 Updated risk management table.

## **11.8 PDR - Preliminary Design Review.**

### 11.8.1 PDR Preparation

PDRs will be conducted for each MUTC Version. Prior to a review, the Supplier will prepare and submit the survey document and the presentation for AHCo approval. The document and presentation will include at least the following topics:

- 11.8.1.1 At this stage, the Supplier will include a reference to each requirement that appears in the Tender or to requirements added during the SRR & SDR.
- 11.8.1.2 Detailed project Gantt, including required resources, dependence, and constraints on external and internal factors, analysis of critical path in Gantt.
- 11.8.1.3 The complete HLD shall include:
  - 11.8.1.3.1 Detailed architecture of the system, including components, modules, and interfaces. The Supplier shall indicate the usage of COTS, open-source code and public directories.
  - 11.8.1.3.2 System's infrastructures.
  - 11.8.1.3.3 Cloud services (AWS) underlying technology, components, scale and projected costs YoY.
  - 11.8.1.3.4 UX/UI – Perception, screens, reports, functional operating interfaces.
  - 11.8.1.3.5 Cyber security architecture, solution tools and code signature tools, procedures, etc.
  - 11.8.1.3.6 Growth capabilities.
  - 11.8.1.3.7 System's business continuity, backup, and recovery solution, including DRP.
- 11.8.1.4 Updated product tree and WBS.
- 11.8.1.5 Detailed system performance.
- 11.8.1.6 Principles of the system's maintenance, including methodology and maintenance team.
- 11.8.1.7 Testing - QA/QC - concept of testing and monitoring ability, mechanisms, level of testing, initial testing analysis, etc.
- 11.8.1.8 Status of the list of topics, action items and tasks from the SDR survey.
- 11.8.1.9 Full quality management plan, including details of the quality control and assurance team and reference to all phases of the project.
- 11.8.1.10 Initial ILS program - including the presentation of the concept of literature and the training concept.

11.8.1.11 Updated risk management table.

11.8.1.12 AHCo may request a POC regarding specific system modules or capabilities. It is clarified that the schedule for performing the POC (if required), is included in the overall schedule.

## **11.9 CDR - Critical Design Review.**

### 11.9.1 CDR preparation

CDRs will be conducted for each MUTC Block and Version. Prior a review, the Supplier will prepare and submit the survey document and the presentation for AHCo approval. The document and presentation will include at least the following topics:

11.9.1.1 At this stage, the Supplier will include a reference to each requirement which appears in the Tender documents or to requirements added during the SRR, SDR & PDR.

11.9.1.2 Status of the list of topics, action items and tasks from the PDR survey.

11.9.1.3 An updated detailed project Gantt, including required resources, dependence and constraints on external and internal factors.

11.9.1.4 Detailed planning (LLD Low-Level Design) of the MUTC which will include:

11.9.1.4.1 Design of the MUTC, including components, modules, interfaces, databases, infrastructures, UX/UI and AWS components, services and architecture.

11.9.1.4.2 A detailed list of all COTS, directories, open-source code, and components utilized by the MUTC, including the necessary releases and digital signature information.

11.9.1.4.3 Cyber security solution tools and digital signature tools, etc.

11.9.1.4.4 Design and description of the growth capacity of the MUTC.

11.9.1.4.5 Design of the business continuity solution.

11.9.1.4.6 UX/UI.

11.9.1.5 Updated product tree and WBS.

11.9.1.6 Backup and restore (RPO / RTO) processes within the BCP / DRP.

11.9.1.7 Testing - QA/QC - concept of testing and monitoring ability, mechanisms, level of testing, initial testing analysis, etc.

11.9.1.8 Expected reliability and availability.

11.9.1.9 Full installation plan including required coordination with 3<sup>rd</sup> party entities.

11.9.1.10 Detailed ILS including the training program.

11.9.1.11 Organization plan for production and supply according to the Gantt chart.

11.9.1.12 System operation procedures.

11.9.1.13 Documentation plan of the entire project.

11.9.1.14 Updated risk management table (according to the planning stage).

11.9.1.15 AHCo may request a POC regarding specific system modules or capabilities. It is clarified that the schedule for performing the POC (if required), is included in the overall schedule.

## **11.10 System Installation Readiness Review**

### 11.10.1 Time period

The Supplier shall conduct a System Installation Readiness Review at least two weeks prior to the formal installation date.

#### 11.10.2 Installation plan overview

This review will provide a comprehensive overview of the installation plan and ensure alignment with project requirements.

#### 11.10.3 The review content

The review content should include, but not be limited to:

11.10.3.1 An outline of the installation timeline.

11.10.3.2 Roles and responsibilities of all personnel involved, including the participation of AHCo personnel.

11.10.3.3 Step-by-step procedures for installation.

11.10.3.4 Identification of required resources and services.

11.10.3.5 Contingency plans for potential issues.

#### 11.10.4 Quality assurance measures

Additionally, the Supplier shall present quality assurance measures and testing plans to verify system functionality upon installation.

#### 11.10.5 AHCo's review and approval

AHCo shall review and approve the installation plan to authorize the commencement of formal installation activities, ensuring all prerequisites are met and mitigating potential risks associated with deployment.

### 11.11 Deliverables & Schedule

#### 11.11.1 General

The Project shall be executed using a spiral development methodology. Block 1 shall be delivered in three sequential Versions (Version 1, Version 2, and Version 3), each of which shall include design, development, integration, testing, deployment, and trial-run activities for the content allocated to that Version (See section 11.2). The detailed functional allocation among the three Versions of Block 1 shall be finalized during the design process, in accordance with this SOW and subject to AHCo approval.

#### 11.11.2 Maximum delivery time

The maximum delivery time for each Block 1 Version, calculated from ARO, shall be as follows:

- Version 1 – no later than 12 months from ARO
- Version 2 – no later than 18 months from ARO
- Version 3 – no later than 24 months from ARO

For the purpose of the Version schedule, delivery of a Version shall mean completion of the activities and deliverables required for that Version, including completion of the applicable design reviews, implementation, testing, and deployment on the operational network, but excluding the trial-run period, which may be conducted in parallel with the development of the subsequent Version.

### 11.12 Deliverables Documents

#### 11.12.1 General

The Supplier shall submit the detailed documents and drawings for approval of AHCo before starting development and implementation.

#### 11.12.2 Required documents.

As part of the spiral design and implementation of the MUTC, all documents shall be continuously updated with all changes as they are made until final commissioning. For each Version, these documents shall include at least the following:

- 11.12.2.1 **Project Management Plan (PMP)** – Detailing all assignments to be performed, allocating the resources required including the schedule of stages and milestones until completion of the project, its designs, development, implementations, testing, integration, QA, and QC activities, training, evaluation and trial-run to the operational phase. The detailed schedule shall correspond to the main milestones and times.

**Delivery schedule:** Initial version at project kick-off.

- 11.12.2.2 **Software Requirements Specifications (SRS)** - a detailed specification document of all the software to be developed as part of the project, whether adaptation to existing contractor and sub-contractor software or development of new software to comply with the requirements in the Tender. The descriptions in the SRS shall be linked and traceable to the requirements in the Tender.

**Delivery schedule:** Part of the documentation for each CDR.

- 11.12.2.3 **Preliminary Design Document (PDD)** - specifying the complete MUTC design. The PDD shall include the entire System with all its components and modules, and its interfaces, internal (between the system's modules) and external (between the MUTC to external systems of AHCo and other relevant organizations).

**Delivery schedule:** Part of the documentation for each PDR.

- 11.12.2.4 **System Design Document (SDD)** - A detailed design document specifying the complete System. The SDD will include the entire System with all its components, modules, and interfaces. The SDD shall also include detailed specifications and plans which accommodate all the requirements of this project and additional infrastructure specifications and plans if needed. The SDD shall be linked and traceable to the requirements in this Tender. The SDD shall be continuously updated with all changes as they are made, until final commissioning.

**Delivery schedule:** Part of the documentation for the CDR.

- 11.12.2.5 **Infrastructure Survey report** – The Supplier will conduct a survey of the infrastructure and services to verify the utilization of the AHCo's infrastructure services, both on-prem and cloud, and to identify any additional infrastructures, or infrastructure upgrades, required for the MUTC's infrastructures and services after the project kick-off. The survey will also include the detectors, Outstation Devices, and external systems that will be integrated with the MUTC – most of them provided by 3<sup>rd</sup> parties.

Subsequent to this survey, the Supplier will provide AHCo with an Infrastructures Review report which verifies the MUTC compliance with these infrastructure and services and an analysis of the required actions by the Supplier in order to fill related gaps (if existing) to fulfill the full scope of the requirements outlined in this Tender. The report shall be presented for AHCo approval.

**Delivery schedule:** No later than the SDR for Version 1.

- 11.12.2.6 **Software Component Classification Document** - the Supplier shall submit a Software Component Classification Document listing all major software components, modules, interfaces, scripts, adapters, configuration tools, and custom developments included in the MUTC solution, and shall classify each such item as Foreground IP, Background IP, Third-Party IP, or Open-Source Component.

Foreground IP shall include all software components, source code, scripts, interface adapters, configurations, data models, reports, dashboards, workflows, rule sets, and other deliverables specifically designed, developed, customized, or created for AHCo under this Agreement, including any modifications made to existing components for the specific needs of AHCo, unless explicitly approved otherwise by AHCo in writing.

**Delivery schedule:** No later than the System SDR

- 11.12.2.7 **ICD – External ICD Report** – shall include all the required interfaces between the system and external systems and devices. The external ICD report shall also describe the interfaces between the system and the infrastructures and the interfaces between the main system and its backup cluster, on-site and at the DR site to external systems and devices. The ICD report shall include a document for each type of interface.

**Delivery schedule:** The initial version shall be part of the documentation of the PDR of each Block and Version. The final version shall be part of the documentation of the CDR of each Version.

**11.12.2.8 Test Readiness Document (TRD)** - A detailed document specifying the system status and contents –the testing process including test plans, cases, allocated resources, test results recording and analysis plan for each type of test (i.e., FAT, SIAT, SAT). A TRD document shall be prepared for each major test session: FAT, SIAT, and SAT.

**Delivery schedule:** TRD for FAT shall be delivered two (2) weeks before FAT initiation and TRD for SIAT and SAT shall be part of the documentation of each TRR of each Version delivery.

**11.12.2.9 Version-Release Readiness (VRR)** – The VRR shall include at least the following: the list of system features included in the release and the status of each feature tests and test results, the list of known existing bugs, Installation procedures, and Version release notes.

**Delivery schedule:** Part of the documentation of each TRR.

**11.12.2.10 Training concept documentation** - A document describing the concept, methods and tools for conducting training for all system users. The documentation will include separate documentation for each category of user training.

**Delivery schedule:** The initial version shall be part of the documentation of Version 1 PDR. The final version shall be part of the documentation of Version 1 CDR, with adaptations based on changes in later versions.

**11.12.2.11 Maintenance concept specification** - a detailed specification document regarding maintenance concepts, methods, and procedures required to maintain the MUTC and all its components in perfect working condition.

**Delivery schedule:** The initial version shall be part of the documentation of the PDR of each Version. The final version shall be part of the documentation of the CDR of each Version.

**11.12.2.12 System's delivery documents** – Documents to be delivered before the System's delivery (at least 14 days before the delivery):

**11.12.2.12.1 MUTC as-built document** – This document will describe the MUTC architecture, components and modules including COTS and open-source components and its interfaces to external systems and infrastructures, as delivered to AHCo.

**11.12.2.12.2 MUTC User Manual** – This document will describe all system operations and shall include a visual explanation of each operational function and relevant displays. The MUTC User Manual shall be divided into different System users (e.g., MANTAM operators, external users, etc.).

**11.12.2.12.3 Technical manual** - Technical manual for the maintenance staff, and system administrators - This document will describe the system's technical operations, system configuration, troubleshooting fault diagnostics and corrective maintenance which can be resolved by the site maintenance staff. The technical manual will also include all the procedures to be performed as a result of the catastrophic failure of the MUTC to ensure a Functional Continuity and Recovery Plan. The procedures will also include the migration of the system to the DR site. The technical manual shall include visual explanations of each operational function and relevant displays.

**11.12.3 Inspection and pre-approval of AHCo**

The deliverables shall be supplied by the Supplier for inspection and pre-approval of AHCo as described for each document (digital Microsoft Word files).

**11.12.4 Summary presentation**

The Supplier shall prepare a summary presentation, for all the above deliverables, as part of the relevant Design Reviews.

# 12 Installation, Testing and System Handover

## 12.1 General

### 12.1.1 Formal acceptance tests

The Supplier shall conduct formal acceptance tests, for each Block and Version, to demonstrate satisfactory compliance of the MUTC with all its requirements, functional and non-functional. The Supplier shall prepare a VCRM which describes the techniques and methods for validating and verifying each requirement.

### 12.1.2 Order of execution

The tests shall be conducted sequentially. Adequate (benchmark or better) capabilities and performance of the MUTC in each Acceptance Test is a mandatory pre-requisite for conducting the next acceptance test. FAT success is a mandatory pre-requisite for conducting the SIAT, and SIAT success is a mandatory pre-requisite for conducting the SAT. The benchmark is the MUTC SDD, including subsequent amendments/ waivers from formal Design Reviews.

### 12.1.3 TRR

12.1.3.1 Before each Block and Version acceptance tests period, a formal Test Readiness Review (TRR) shall be conducted by the Supplier to determine whether the test procedures are complete and traceable to the VCRM and to ensure that the Supplier is prepared for formal testing. Test procedures shall be evaluated for compliance with test plans and descriptions and for adequacy in accomplishing test requirements. The timeline leading to each TRR shall be approved by AHCo.

12.1.3.2 The following topics should be presented by the Supplier, and reviewed, evaluated, and approved by AHCo before advancing to the acceptance test:

12.1.3.2.1 **Compatibility:** Test plan and test setup, supporting test objectives.

12.1.3.2.2 **Traceability:** Test procedures covering all the requirements to be demonstrated (according to the VCRM) and including a direct reference to those requirements.

12.1.3.2.3 **Completeness:** Test procedures demonstrate proper MUTC functionality for a full set of valid inputs, as well as a relevant set of invalid/erroneous inputs, where applicable.

12.1.3.2.4 **Maturity:** In preparation for the acceptance test, the Supplier shall perform informal tests of the MUTC, to ensure its readiness and maturity. A list of known system Malfunctions and their impact on the test shall be presented.

12.1.3.2.5 **Preparedness:** The Supplier shall be thoroughly familiar with the testing environment, and technically compatible and ready to install, configure and operate the MUTC in this environment, in preparation for and during the test.

12.1.3.2.6 **Availability:** Appropriate and sufficient Supplier resources (including where necessary 3rd party support equipment and COTS testing tools) are allocated for the acceptance test, to perform it efficiently and on time. A detailed test schedule shall be presented.

12.1.3.2.7 **Documentation:** The Supplier shall send a TRD for review, comments, and approval at least 30 days prior to conducting the test.

### 12.1.4 Testing location

Testing location will be according to each type of test as detailed in section 12.2, and shall also be listed in the VCRM.

### 12.1.5 The approval of tests phases

Approval and issuance of certificates to the various test phases shall be subject to approval and acceptance in accordance with the pass/fail criteria and fulfillment of the associated milestones.

### 12.1.6 Stopping test execution

AHCo in its sole discretion may cease the acceptance test execution based on the discovery of severe bugs or major module Malfunction during the execution of the test, until those are fixed by the Supplier and ready for re-acceptance test.

#### 12.1.7 Personnel and resources

During the test phases, the Supplier shall provide the necessary qualified personnel and resources to monitor and assist with operation and maintenance problems and to investigate and report on Malfunctions and errors.

## 12.2 Detailed test requirements:

For each of the MUTC Block and Version, the Supplier shall conduct the following tests (the tests are to be conducted in the sequence as appears below):

#### 12.2.1 System Factory Acceptance Test (FAT)

**Location:** Supplier Testing environment.

#### 12.2.2 System Integration Acceptance Test (SIAT)

**Location:** AHCo Testing environment.

#### 12.2.3 System Acceptance Test (SAT)

**Location:** AHCo Testing environment.

#### 12.2.4 Documentation to be supplied by the Supplier in support of each test is as follows:

##### 12.2.4.1 VCRM describes the techniques and methods for validating and verifying each requirement in the Tender.

##### 12.2.4.2 Test plans, procedures, and specifications:

- a. The tests are to be conducted with reference to the VCRM.
- b. Full test procedure.
- c. Test specifications that define the expected results for each test.
- d. Location of the test.
- e. The sequence in which the tests will be conducted.
- f. Any relationships and dependencies between tests.
- g. Required regression tests - tests aimed at ensuring that the new MUTC developments have not negatively impacted the existing functionality of the MUTC.

##### 12.2.4.3 Approval of test plan and procedures:

- a. The Supplier shall present all test plans and procedures for the approval of AHCo. No testing shall commence before the documentation is approved by AHCo.
- b. Test procedures shall be submitted to AHCo for approval not less than 6 weeks before the commencement of any acceptance test.

##### 12.2.4.4 Records:

The Supplier shall keep records of all forms of testing. The Supplier shall use a COTS tool to manage all test records.

#### 12.2.5 Required preparation period for AHCo.

The Supplier shall provide sufficient notice to AHCo of not less than 2 weeks before the commencement of each test.

#### 12.2.6 Determining Success or Failure of Tests:

- a. Test success shall be declared after a successful demonstration of compliance with all of the requirements which are defined in the MUTC design document, including subsequent amendments/waivers from formal Design.
- b. In the event of acceptance test failure, AHCo retains the right to the final decision on suspension, extension, and scheduling of re-testing. All required re-testing shall be at the Supplier's expense.

#### 12.2.7 Documenting Malfunction

Any Malfunction encountered during the test shall be documented by the Supplier. The documentation shall include a detailed description of the Malfunction, the actions/conditions causing or leading to it (if possible), the recommended severity level of the Malfunction based on its impact on system performance, and the rectification action.

The Supplier shall recommend the appropriate severity level of each Malfunction; however, the final decision shall be made by AHCo.

#### 12.2.8 Severity levels

The following definition of severity levels shall be applied:

- a. Severity Level 1 – Critical impact:

**Definition:** A malfunction that causes a complete system outage or poses direct risk to safety or security.

**Scope:** No viable Work-Around exists; operations cannot continue until resolved.

Examples:

- Central MUTC or SIM module crash preventing all command-and-control operations.
- Cybersecurity breach exposing sensitive data or compromising system integrity.
- Failure of communications backbone leads to total loss of roadside device connectivity.
- Loss of user interface visualization and access by operators.

- b. Severity Level 2 – Severe impact:

**Definition:** A malfunction resulting in loss or major degradation of critical system capability, causing significant reduction in operational performance.

**Scope:** Limited Workarounds may exist, but core functionality is impaired.

Examples:

- The system provides only raw data visualization (no processing, no performance metrics, and no LOS calculation available).
- Limited control over road signals, such as inability to issue coordinated plans or restrictions to local/manual operation only.
- Automated Response Plans are unavailable, forcing operators to rely solely on manual interventions.
- Major degradation in data processing pipelines resulting in delayed or incomplete situational awareness.

- c. Severity Level 3 – Medium impact:

**Definition:** A malfunction resulting in loss or degradation of a non-critical capability, or minor degradation of a critical capability that does not significantly impair traffic operations.

**Scope:** Workarounds are available; operational continuity is maintained, but efficiency, analysis, or flexibility may be affected.

Examples:

- Errors in offline analytics functions (e.g., BI dashboards, historical reports).
- Loss of data extraction capabilities within the user interface for non-critical information (statistics, less used metrics).
- No playback capabilities for past traffic events or operator sessions.
- Loss of configurability functions such as updating thresholds, defining traffic anchors, or adjusting operator preferences.
- Fault in the Rangers module (or other support modules) that does not impact real-time operational control.

d. Severity Level 4 – Low impact

**Definition:** A minor malfunction or imperfection that has no impact on operational continuity, safety, or core system functions.

**Scope:** Purely cosmetic or convenience-related; can be resolved in routine maintenance.

Examples:

- a. Typographical errors in the operator interface.
- b. Misaligned icons or layout inconsistencies.

12.2.9 Test results categories.

Individual test results shall be divided into the following categories:

- 12.2.9.1 **Absolute Failure:** A test failure that is classified as Severity Level 1. The testing shall be stopped until the fault is rectified. The complete system shall then be fully retested.
- 12.2.9.2 **Standard Failure:** A failure that influences certain capabilities and is classified as Severity Level 2. All testing regarding these capabilities shall be stopped until the fault is rectified. After the fault is rectified, a re-test shall be performed, including regression tests where needed.
- 12.2.9.3 **Defect:** A non-compliant condition that is classified as Severity Level 3 or 4 and has no significant impact on the continued testing or operation of the system. The observed defect shall be resolved by an agreed clearance date. The clearance date shall not exceed the test period.
- 12.2.9.4 **Pass:** The observed test result matches, in full, the result detailed in the test specification.

12.2.10 Test summary report

Following each test's phase, the Supplier shall prepare a test summary report, containing full test results, a detailed list of Malfunctions found during the test, and a corrective action plan by the Supplier. This report shall be submitted to AHCo for review, evaluation, and approval two weeks after test completion.

12.2.11 Specific tests:

12.2.11.1 System Performance & Load test

The Supplier will perform prior to the execution of the SAT, a system performance & load test by simulating a heavy load on the various MUTC modules and components and interface for evaluating that the system performance response time meets the defined requirements. Successfully passing the system load test is a pre-request to commence the SAT.

12.2.11.2 System Penetration and Security tests

12.2.11.3 Cybersecurity and security aspects should be taken into account during the entire project life cycle.

12.2.11.4 This test will be performed by AHCo, using a 3<sup>rd</sup> party tool (or vendor) in order to validate the cybersecurity level of the delivered system Block and Version.

12.2.11.5 This test will be performed during the SAT and will be considered as part of the SAT.

12.2.11.6 AHCo may conduct penetration and cyber security tests as part of the delivery approval process to any of the MUTC's Block and Version delivered by the Supplier.

12.2.11.7 The tests shall include the verification and validation of all COTS, directories, open-source code and components digital signatures, based on the Supplier's COTS, directories, open-source and component digital signatures up-to-date catalog.

12.2.11.8 The results of the test will be submitted to the Supplier who is responsible for correcting the Malfunctions.

12.2.11.9 Code Review

AHCo may decide to perform a code review for any code which will be developed under the Agreement. The Supplier shall deliver the software in a manner that allows AHCo to perform a code review and code security tests. Specific instructions are detailed in section 12.8.1.8.

### **12.3 Factory Acceptance Test (FAT)**

12.3.1 FAT test environment.

The FAT will take place in the Supplier's test environment and shall cover all requirements, verifications and validation which do not need AHCo GFEs and special interfaces (which the Supplier is unable to provide in its test environment). For the user experience test – AHCo might require that the Supplier testing environment connect to dedicated displays installed at a site approved by AHCo in Israel.

12.3.2 The test shall demonstrate at least:

12.3.2.1 Internal/stand-alone MUTC functionality.

12.3.2.2 The full two-way interface of the MUTC for each of the interfaces.

12.3.2.3 User experience test –

The Supplier shall include a User Experience (UX) test as part of the FAT. This UX test will involve the active participation of AHCo's operators, who will provide detailed feedback and observations based on their interaction with the MUTC. All feedback and remarks gathered from AHCo's operators during the FAT shall be documented and addressed, with necessary modifications and improvements integrated into the system's development process. This iterative refinement shall continue through to the SAT phase, ensuring that the final product meets AHCo's operational requirements and usability expectations.

12.3.3 Fat for COTS

For COTS, upon the Supplier receiving prior AHCo approval, the FAT may be replaced by stamped quality testing documents from the manufacturer.

12.3.4 FAT scope

FAT shall be conducted for every MUTC Block and Version.

### **12.4 System and Site Integration Acceptance Test (SIAT)**

12.4.1 SIAT test environment.

SIAT shall be conducted at the AHCo non-production environment, by AHCo personnel in collaboration with the Supplier. The AHCo's testing environment is a scaled-down representation of the MANTAM, containing all its major systems, interfaces, and infrastructure, either as exact replicas, reduced-capability systems, or simulations.

12.4.2 MUTC version for SIAT

As stated in Section 5.9.3.1, the Supplier shall install the required version of the MUTC in the non-production environment before each SIAT.

12.4.3 Prior to a SIAT

As part of the infrastructure survey, the Supplier shall examine the AHCo non-production environment to evaluate the available services, infrastructures, interfaces and simulations needed for the SIAT.

#### 12.4.4 The SIAT objective

The SIAT shall verify and validate the requirements of all MUTC interfaces. The Supplier shall describe as part of the test/s procedures the usage of simulators that exist in the AHCo non-production environment or additional simulators provided by the Supplier. The Supplier's simulators shall be installed at the AHCo non-production environment and shall be part of the system/s deliverables.

#### 12.4.5 The test shall demonstrate at least:

##### 12.4.5.1 MUTC operation in a MANTAM-like environment.

##### 12.4.5.2 Integration of the MUTC with external systems via various types of interfaces.

##### 12.4.5.3 End-to-end functionality and performance – proper operation of all the systems together, with a focus on multi-system interfaces.

#### 12.4.6 SIAT scope

SIAT shall be conducted for every MUTC Block and Version.

### 12.5 System Acceptance Test (SAT)

#### 12.5.1 SAT test environment.

SAT shall be conducted by the Supplier in AHCo's non-production environment, in collaboration with MANTAM personnel.

#### 12.5.2 MUTC version for SIAT

As stated in Section 5.9.3.1, the Supplier shall install the required version of the MUTC in the non-production environment before each SAT.

#### 12.5.3 SAT objectives

The test shall focus on the main work processes and capabilities of the MUTC, to demonstrate end-to-end functionality and performance – proper operation of all the systems, in real-time input and load conditions.

#### 12.5.4 SAT scope

In general, the SAT shall be conducted for a full Block or Version only, but AHCo may decide to conduct a partial SAT for a partial Version. In such a case, the full SAT must be completed to approve the milestone.

#### 12.5.5 Noncritical bugs

Problems and bugs which are categorized as not critical may be added to the content of the next Version of the MUTC after specific approval by AHCo.

#### 12.5.6 Verify compliance of a MUTC block and version

SATs shall be the final testing procedure to be performed to verify the compliance of the MUTC Block and Version with all the requirements and to hand over the system to AHCo after the formal SAT results are approved by AHCo.

### 12.6 Installation and Delivery

#### 12.6.1 Upon successful completion of the relevant SAT stage, the Supplier shall install the approved Version of the MUTC in AHCo's production and DR environments.

#### 12.6.2 The installation and delivery stage shall include all activities required to make the relevant Version operational in the production environment, including system deployment, configuration, connectivity, and verification of readiness for operation.

#### 12.6.3 The installation shall include the full implementation and activation of all required interfaces with external systems, Outstation Devices, and Signalized

Intersections applicable to the relevant Version.

- 12.6.4 For the purpose of this SOW, delivery of a Version shall mean completion of all activities, deliverables, reviews, tests, installation activities, and trial-run or acceptance milestones applicable to that Version, as defined in this SOW. This shall include, but not limited to, completion by the Supplier of all setup, parameter definition, and configuration activities required to enable the traffic management and control functions of the system, including links, route definitions, metrics, LOS definitions, thresholds, and any other operational configurations necessary for proper system operation.

## **12.7 Trial Run**

### **12.7.1 General**

After the successful completion of the SAT for each Block and Version, and a successful installation and delivery of the Block and Version, AHCo will conduct a trial-run phase of 90 days to validate the proper continuous functionality of the system.

### **12.7.2 During this period, the Supplier shall:**

- 12.7.2.1 Provide on-site instruction and technical assistance to the MANTAM operators, with regard to the MUTC.
- 12.7.2.2 Complete all required training.
- 12.7.2.3 Document and classify new MUTC faults/anomalies, when encountered.
- 12.7.2.4 If Severity Levels 1 or 2 faults are detected, the Supplier shall rectify the fault, conduct re-tests and install the new fixed version.
- 12.7.2.5 Any fault of Severity Levels 1 or 2 that occurs during the trial run will require that the fault is resolved and the system is tested, and only then the trial run will be restarted for a period of 90 days.
- 12.7.2.6 Conduct weekly debrief with MANTAM operators, to review and assess MUTC operation.

## **12.8 System Handover to AHCo ("Handover")**

### **12.8.1 The system handover procedure**

The system handover procedure shall be subject to the fulfillment of the following conditions:

- 12.8.1.1 Successful completion of all test phases described above, including the trial run.
- 12.8.1.2 Completion of installation and integration of the MUTC, including all interfaces to external systems, Outstation Devices and Signalized Intersections.
- 12.8.1.3 Successful completion of all training of all types of personnel as required, to AHCo's satisfaction.
- 12.8.1.4 Supply of 3 sets of full As-Made Documentation (specifications and plans) approved by AHCo as complete and accurate sets representing the supplied and installed MUTC.
- 12.8.1.5 Supply of 3 sets of the complete and latest version of updated MUTC Documentation (i.e., MUTC User Manuals, maintenance manuals, and system configuration manuals).
- 12.8.1.6 Supply of all licenses for all software/components and any part thereof of the MUTC that require any license to AHCo's satisfaction.
- 12.8.1.7 Supply AHCo with a complete source code for Foreground IP (as defined in the Agreement), together with all documents and information necessary to maintain, utilize and further develop the code.
- 12.8.1.8 The Supplier shall deliver the software with all of its code (code for Foreground IP) written in English. The code shall be written in a clean and organized manner, using well-defined objects and functions. The code shall be fully documented, including comments and explanations. The code shall comply with international standards, such as PEP8, Google Java Style Guide, or Microsoft Visual Studio Style Guide.
- 12.8.1.9 Submission of the Maintenance Services Plan for AHCo's approval.
- 12.8.1.10 Supply AHCo with written approval or license as required by Israeli law from any Israeli agency as relevant.

#### 12.8.2 The Handover date

A written handover approval from AHCo confirming that all of the above terms have been met shall serve as handover certification for all purposes of the Agreement. The date of such approval shall be considered the Handover date for all purposes of the Agreement.

# 13 Training

## 13.1 General

### 13.1.1 Supplier responsibility

The Supplier shall be responsible for training AHCco-designated personnel according to the requirements specified herein. The specifics of the training courses and training timeline shall be subject to AHCco's approval. The training courses defined in this Chapter constitute the baseline training program required for the initial deployment and commissioning of the MUTC system.

### 13.1.2 AHCco approval of the training plan

AHCco shall approve the timeline, content and duration of each course, in accordance with section 13.1.4.3 herein. AHCco shall nominate trainees and approve the location and dates of the training course with the Supplier. The Supplier shall submit a detailed Training Plan for AHCco approval. The Training Plan shall include the proposed syllabus, duration, training materials outline, and training schedule for each course.

### 13.1.3 Location

The training courses will take place in Israel at Supplier's premises, or AHCco's facility, subject to prior approval of AHCco. The course instructor must be physically present in class. Where appropriate and subject to AHCco approval, certain update or refresher sessions may be delivered through remote or hybrid training methods.

### 13.1.4 Training courses requirements.

13.1.4.1 The training courses shall include the provision of full course notes and copies of all presentation material. Training materials shall include course presentations, training notes, and practical exercises where applicable.

13.1.4.2 The training and training presentations and material concerning MUTC operators shall be in Hebrew. Training presentations and material concerning other professional and technical personnel shall be in Hebrew or English.

13.1.4.3 Training courses shall cover all MUTC aspects with a focus on operational and maintenance aspects. The minimum training is necessary to bring the designated AHCco employees to the level of proficiency required for performing their respective duties.

13.1.4.4 The duration and syllabus of each course will be presented and submitted to AHCco at the CDR for approval. AHCco is entitled to request changes in the syllabus or the duration of each course. As a design goal, a duration of a minimum of 5 days shall be set for each course. The final duration and detailed syllabus of each course shall be determined within the Training Plan submitted by the Supplier and approved by AHCco.

13.1.4.5 Wherever there is a duplication of course content, the Supplier may recommend mutual guidance for multiple roles and later separation for continuing guidance for specific roles.

13.1.4.6 All courses shall include oral lectures in class and on-the-job practical training.

13.1.4.7 The Supplier must include means for evaluating the success of training, such as tests, assignments, and trainee feedback, and will be responsible for retraining MUTC operators and maintenance personnel to acquire the necessary skills. The evaluation means will be approved by AHCco.

13.1.4.8 Successful completion of training will be approved by AHCco.

13.1.4.9 In addition to the courses described ahead, focused maintenance and operation training will be provided by the Supplier for each Block and Version delivery to cover all changes/add-ons to the MUTC and will cover at minimum the Block and Version release notes for the operational, technological and maintenance aspects. The scope of the training for each Block will be determined according to the modification volume of the Version, and approved by AHCco. Such training sessions shall focus on the operational, technological and maintenance implications of the relevant Version release and may be delivered as targeted update sessions addressing the changes introduced in the system.

### 13.1.5 Training Scope Clarification

- 13.1.5.1 The training activities (courses and addition focus training) defined in this Chapter represent the baseline training program required to support the implementation and operation of the MUTC system.
- 13.1.5.2 The main training courses shall be provided to prepare AHCo personnel to operate and maintain MUTC Version 1 and shall therefore be completed before the trial run of Version 1. In addition, complementary training sessions shall be provided for each subsequent Version.
- 13.1.5.3 Additional training activities required during the operational life cycle of the system, including follow-up training and training for additional personnel, may be ordered by AHCo as an additional workload in accordance with Section 9.2.16.

## 13.2 Operators' course

### 13.2.1 Operators course objectives

The Operators course shall provide the trainees with complete knowledge of the MUTC capabilities and qualifications needed to operate the MUTC.

### 13.2.2 Operators course timeframe

The training sessions shall be provided at least 3 weeks prior to the MUTC trial run period of Version 1.

### 13.2.3 Amount of operators' course

The Supplier's Fixed Price Proposal shall include three (3) operators' course periods.

## 13.3 Administrator course

### 13.3.1 Administrator course objectives

- 13.3.1.1 The Administrator course shall provide operational, administration, and technical knowledge of the MUTC.
- 13.3.1.2 The course will provide traffic engineers and system engineers the knowledge for performing deeper administration operations in the system, such as system configurations, setting rules and Response Plans, managing Signalized Intersection definitions, etc.
- 13.3.1.3 The Supplier may suggest a separation of days between the system engineers and traffic engineers based on the relevant content.

### 13.3.2 Administrator course timeframe.

The Administrator course shall be conducted before the SAT of Version 1, to enable the staff to effectively participate in the System SAT.

## 13.4 Maintenance technical course

### 13.4.1 Maintenance course objectives

- 13.4.1.1 The maintenance training shall provide knowledge of the MUTC and qualifications to deal with all its functions.
- 13.4.1.2 The course shall focus on the MUTC software aspects, taking into consideration the MUTC's maintenance requirements.

### 13.4.2 Maintenance course timeframe

Training sessions shall be conducted at least 3 weeks prior to the trial run period of Version 1.

## 13.5 Traffic engineers' course

### 13.5.1 Traffic engineer's course objectives

The traffic engineer's course shall focus on the functional aspects of the MUTC that are under the responsibility of the traffic engineer. The course shall include as a minimum:

- 13.5.1.1 Managing Signalized Intersection definitions
- 13.5.1.2 Managing Sub-Networks of Signalized Intersections, Green-Wave definitions, Double Signalized Intersections definitions, and Configurations.
- 13.5.1.3 Defining, calibrating, managing, and monitoring the performance of Signalized Intersection managed by the Centralized Adaptive Management module.
- 13.5.1.4 Managing Traffic Light Timing Plans.
- 13.5.1.5 Managing Predefined Response Plans.
- 13.5.1.6 Setting rules for Traffic Light Timing Plan changer module.
- 13.5.1.7 Managing traffic entities like links, routes and sub-networks.
- 13.5.1.8 Managing LOS and metrics definitions and thresholds.
- 13.5.1.9 Managing Policies.
- 13.5.1.10 Using the reports module.
- 13.5.1.11 Unless otherwise requested by AHCo, training sessions for traffic engineers shall be provided before the SAT of Version 1.

## 14 Warranty, Support & Maintenance

### 14.1 General

#### 14.1.1 Maintenance Services to the MUTC

14.1.1.1 The Supplier is obligated to supply Maintenance Services to the MUTC, as outlined in this chapter, from the installation of block 1 (Version 1) in the non-production and later in the production environment of AHCo, throughout the Maintenance Period as detailed in section 14.3 below (hereinafter - “**Maintenance Services**”).

14.1.1.2 It is clarified that all the Maintenance Services detailed in this chapter are included in the Yearly Maintenance Fee, as detailed in the Agreement, unless expressly stated otherwise.

#### 14.1.2 Continuous project support

The Supplier shall designate, from the Handover of Block 1 and until the end of the Maintenance Period, an Account Manager or other equivalent qualified representative, who shall serve as AHCo’s primary point of contact for project-related matters that are not limited to routine Maintenance Events. Such matters may include change requests, option orders, future enhancements, follow-up of open commitments, clarification of roadmap-related matters, and coordination of project-level issues requiring involvement of the Supplier beyond the maintenance support function. For avoidance of doubt, such representative shall not be required to be dedicated exclusively to the Project, provided that the representative maintains sufficient familiarity with the Project and is available to perform the responsibilities defined in this Section. For the avoidance of doubt, such representative is in addition to the Maintenance Manager appointed by the Supplier according to Section 11.1 above.

#### 14.1.3 Chapter purpose

14.1.3.1 The purpose of this chapter is to define the general requirements, guidelines, and tasks according to which the Supplier will provide the Maintenance Services, in such a way that will ensure that the MUTC successfully meets and fully complies with all the detailed SOW specifications and the Agreement, and without derogating from the above - will apply all best practices to achieve such goal.

14.1.3.2 Furthermore, it should be clarified that everything detailed in this chapter constitutes the minimum requirement. The Supplier must perform additional actions, as required, with the purpose of providing the Maintenance Services, as much as this is required, in accordance with best practices.

### 14.2 Contents of the Maintenance Services

#### 14.2.1 Supplier responsibilities

14.2.1.1 The Supplier is fully responsible for all the services needed for a successful end-to-end operation of the MUTC.

14.2.1.2 The Maintenance Services shall include all components, activities, and resources which are needed by the Supplier, for a successful operation of the MUTC.

#### 14.2.2 The Maintenance Service Scope

The Maintenance Services will include, among other things, the following operations (all as detailed below):

14.2.2.1 Supply and management of all the licensing rights of use of all MUTC components and infrastructure tools, which are provided by the Supplier (as detailed in section 14.5 below).

14.2.2.2 Preparation and monitoring of a Service Maintenance plan, for the execution of Maintenance Services, (as detailed in section 14.6 below).

14.2.2.3 Adaptive maintenance - an adaptation of the MUTC software in response to all upgrade events, to keep the MUTC up-to-date and tuned, (as detailed in section 14.7 below).

14.2.2.4 Preventive Maintenance (as detailed in section 14.8 below).

14.2.2.5 Management of the Cloud IT environment, (as detailed in section 14.8.2.12 below).

- 14.2.2.6 System and data backup and restore (as detailed in section 14.10 below).
- 14.2.2.7 Quality assurance (as detailed in section 14.13 below).
- 14.2.2.8 Ongoing Training sessions for the MUTC users (as detailed in section 14.15 below).
- 14.2.2.9 Functional Continuity and Recovery from extreme situations (as detailed in section 14.16 below).
- 14.2.2.10 Technical help desk services (as detailed in section 14.17 below).
- 14.2.2.11 Corrective maintenance - Response to Malfunctions detected in the MUTC, and the implementation of corrections, modifications, and updates to resolve these Malfunctions which are either identified by users or by any other entity (as detailed in section 14.19 below).
- 14.2.2.12 Documentation and reporting (as detailed in section 14.20 below).

#### 14.2.3 Maintenance Services guidelines

All Maintenance Services will be provided in accordance with the general instructions detailed in Section 14.4 below.

#### 14.2.4 Maintenance Services scope

14.2.4.1 The responsibility of the Supplier will apply to all MUTC components and modules, including the following:

14.2.4.1.1 All developments and configurations implemented in the MUTC.

14.2.4.1.2 All the interfaces that are part of the MUTC.

14.2.4.1.3 Any Adaptive Field Equipment provided by the Supplier, along with any ancillary gear and consumable accessories required for installation, housing, connectivity, power supply, and other components, at the designated installation sites.

14.2.4.1.4 MUTC components in the non-production environments.

#### 14.2.4.2 Support of tangent projects

In addition, the Supplier shall participate, as requested by AHCo, in meetings relating to tangent or interfacing projects in order to represent the MUTC system. Such participation may include presenting the MUTC functionality and architecture, presenting the MUTC interfaces and APIs for Outstation Devices and external systems, and participating in preliminary design meetings and kickoff sessions relating to new MUTC functionality or to interfaces with Outstation Devices and external systems.

#### 14.2.4.3 Sanity tests

The Supplier shall participate, as requested by AHCo, in sanity tests of the MUTC and of its interfaces with Outstation Devices and external systems.

#### 14.2.5 Total-Risk engagement mode

The Maintenance Services are in a "**Total-Risk engagement mode**", and the Supplier's liability will be limited only in the cases listed below (unless the Supplier has agreed to regain responsibility):

14.2.5.1 For the On-Premises environment – the responsibility of the Supplier will be limited in accordance with section 14.13 below.

14.2.5.2 For components and means that were not provided by the Supplier - If the Supplier has identified and proved to AHCo's satisfaction that the Malfunction is due to a component or means that were provided by AHCo or by AWS as cloud provider.

14.2.5.3 In case of a Force Majeure event. For this purpose, Force Majeure is defined as a catastrophic event, such as a natural disaster, but not including an act of war, that directly affects the MUTC's operational mode or the Supplier's staff, and while is ongoing the Supplier is prevented from fully complying with its undertakings despite best efforts.

#### 14.2.6 Maintenance Services for Change Orders

Maintenance Services will also be provided for changes ordered by AHCo, in accordance with the change instructions in Section 13 of the Agreement, from the approval of the completion of the Change Order until the termination of the Period of Engagement.

#### 14.2.7 Maintenance during the development period

It is clarified that, during the MUTC development period, and until the Supplier receives AHCo's official Handover of the MUTC – the Supplier is fully obligated to provide Maintenance Services detailed in this chapter, to ensure the successful operation of the delivered components. To avoid any doubt, during such period, the Maintenance Services shall be provided as an integral part of the project development payouts and no additional payment shall be made to the Supplier for the services.

### 14.3 Warranty Period and Maintenance Period

#### 14.3.1 General

After the delivery of Block 1\Version 1, the Supplier will provide maintenance services for the system in parallel with the development and until the handover of the complete Block 1 with its 3 versions. The maintenance services will be based on what is detailed in this chapter.

#### 14.3.2 Warranty Period

The first 12 months after the Handover of MUTC Block 1 will be considered as the "**Warranty Period**", and the Supplier's obligations during the Warranty Period will include all Maintenance Services as described above, free of charge.

#### 14.3.3 Maintenance Period

14.3.3.1 The Maintenance Period of the MUTC will commence once the Supplier receives approval from AHCo that the MUTC has passed inspection and that the Warranty Period has ended (as detailed below) and will end upon termination of the Period of Engagement, as defined in the Agreement (hereinafter - "**Maintenance Period**").

14.3.3.2 During the Maintenance Period, the Supplier will provide Maintenance Services as detailed in this chapter.

14.3.4 At the end of the Warranty Period, the Supplier will be required to:

14.3.4.1 To conduct a set of tests, with a specific emphasis on regressive tests, before commencing the Maintenance Period. AHCo shall grant approval for the test plan at least one month prior to the expiration of the Warranty Period.

14.3.4.2 To verify the latest version of all MUTC components and infrastructure, including any fixes and add-ons implemented during the Warranty Period.

14.3.4.3 To ensure that the completed MUTC is devoid of any Malfunctions.

14.3.4.4 To provide comprehensive resolutions for any Work-Around procedures that were conducted.

14.3.5 The figure below summarizes all Maintenance Periods:

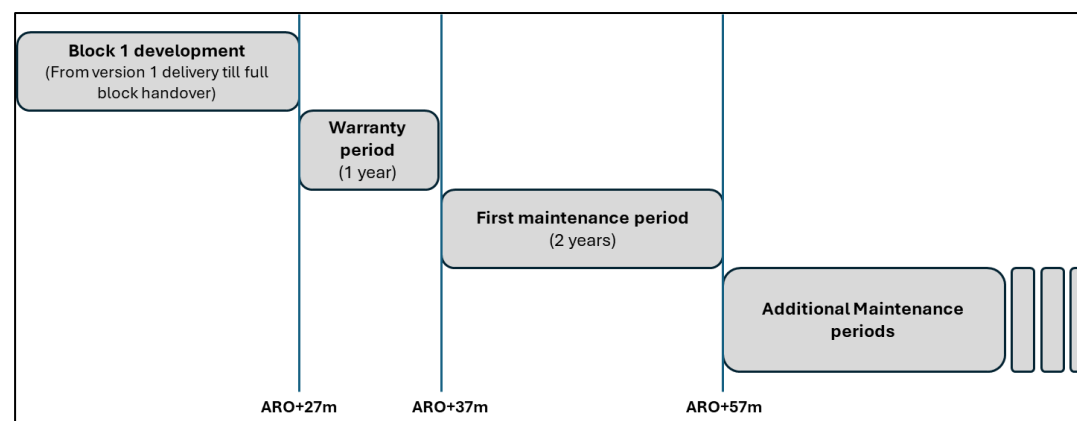

Figure 19 – Warranty and Maintenance Periods

## 14.4 General instructions regarding the provision of Maintenance Services

### 14.4.1 The Supplier responsibilities

- 14.4.1.1 The Supplier shall be responsible, for the compliance of the MUTC with the specifications, performances and capabilities detailed in the SOW, and shall verify that it is free from Malfunctions and from any code which has the effect of disrupting, disabling, harming or otherwise impeding the performance of the MUTC in any manner.
- 14.4.1.2 The Supplier shall perform the Maintenance Services in an efficient, and professional manner to the complete satisfaction of AHCo.
- 14.4.1.3 The Supplier will perform all the Maintenance Services with minimal disruption to the MUTC's ongoing operation. As a rule, no full or partial MUTC downtime is allowed during support and/or Maintenance Services activity. The Supplier is obligated to define Maintenance Services procedures in such a way that will minimize full or partial MUTC downtime, in accordance with the MUTC reliability and availability requirements. The Supplier must get AHCo's specific approval for any kind of downtime (full or partial).
- 14.4.1.4 The Maintenance Service will be provided with a long-term perspective, that will enable the MUTC to operate continuously and properly.
- 14.4.1.5 The Supplier is obligated to provide, as part of the Maintenance Services, all the means required for their delivery, including:
  - 14.4.1.5.1 Professional personnel (as detailed in section 14.4.2).
  - 14.4.1.5.2 All tools, COTS and needed equipment.
  - 14.4.1.5.3 When required for maintenance or corrective actions relating to Adaptive Field Equipment and its ancillary equipment, the Supplier shall be responsible for preparing Temporary Traffic Arrangement plans, obtaining the necessary approvals, and implementing such arrangements.
- 14.4.1.6 The Supplier is required to coordinate the Maintenance Services with AHCo and all the relevant parties.
- 14.4.1.7 The Maintenance Services will be performed by the Supplier or sub-contractors, who are formally certified on behalf of the components' manufacturers to provide the maintenance services. The Supplier must always ensure that, for all the MUTC components, there is an authorized representative, subsidiary or branch of the manufacturers available for the provision of Maintenance Services.
- 14.4.1.8 The Supplier shall promptly replace, modify, upgrade or otherwise correct any Malfunctions of the MUTC, which is not in compliance with the specified levels of performance, functionality or availability outlined in this SOW. Such responsibility shall also include (without limitation) any diagnostic work (after such incapability is demonstrated).
- 14.4.1.9 The condition of the MUTC upon termination of the Period of Engagement: The level of the Maintenance Services and the state of the MUTC shall be such that allows the delivery of the MUTC to AHCo, in a perfect working and operational condition that fully meets the performance and capabilities required under this SOW and the Agreement.
- 14.4.1.10 The Supplier must comply with the required procedure once a termination of the Period of Engagement is executed, as detailed in section 14.21 below.

### 14.4.2 Maintenance technical staff

- 14.4.2.1 The Supplier shall provide all Maintenance Services by qualified technical staff (hereinafter - "**Technical Staff**").
- 14.4.2.2 The size and availability of the Technical Staff shall be sufficient to enable the Maintenance Services to be carried out effectively. The size of the Technical Staff may be changed at AHCo's request, if deemed to be insufficient to provide the Maintenance Services.
- 14.4.2.3 All Technical Staff shall be fully trained in the operation and maintenance of the MUTC.
- 14.4.2.4 The Technical Staff shall be allocated for the entire Warranty and Maintenance Periods.
- 14.4.2.5 The Supplier shall nominate a Maintenance Manager, who shall be responsible for all Maintenance Services. The Maintenance Manager will support and supervise all Maintenance Events for the MUTC.

## 14.5 Licenses and Rights of Use

### 14.5.1 General

As part of the maintenance Services, the Supplier shall provide, among other things, and purchase all the required software licensing agreements and cloud services for maintaining the MUTC fully operational and up to date.

### 14.5.2 Software licensing model

14.5.2.1 The Supplier will acquire and update the software licensing model and rights of use throughout the Warranty and Maintenance Periods, in accordance with the Agreement's requirements, for all the MUTC components, COTS and cloud infrastructure provided by the Supplier.

14.5.2.2 The software licensing model will remain in accordance with the software licensing model approved by AHCo and will include a response to all the required capabilities of the MUTC (including SLA), to the extent of the required use for all the MUTC users and in accordance with the Agreement.

14.5.2.3 In the event of a change in the software licensing model of the MUTC or any of its components - the Supplier is required to provide replacement licensing of equivalent value, in a way that does not change the MUTC capabilities and operational mode in accordance with the requirements of this document.

### 14.5.3 Documenting licensing agreements

14.5.3.1 The Supplier will manage and document all the licensing agreements it acquired for each of the MUTC components and infrastructure tools, including the details of the component manufacturers, agents on their behalf, cloud services and the management of the actual licensing allocation, expiration dates, and renewal dates. AHCo will receive an updated document at least every two years.

14.5.3.2 AHCo may request the Supplier to provide any license information at any time.

14.5.4 The provisions above do not derogate from Section 16 of the Agreement.

## 14.6 Maintenance Services Plan

### 14.6.1 Maintenance plan

14.6.1.1 The Supplier will prepare a Maintenance plan, which includes detailed instructions for all the Maintenance Services activities (hereinafter: "**Maintenance Services Plan**").

14.6.1.2 The Maintenance Services Plan will be submitted for AHCo's approval at least three (3) months before the beginning of each calendar year during the Warranty and Maintenance Periods. The first plan will be submitted as a pre-requisite for Handover approval.

14.6.1.3 AHCo may request modifications to the Maintenance Services Plan submitted by the Supplier, and the Supplier is required to amend the plan in accordance with AHCo's instructions.

14.6.1.4 It is clarified that the Maintenance Services will be performed in accordance with the Maintenance Services Plan, as described above.

14.6.1.5 The Supplier is responsible for continuously monitoring the implementation of the Maintenance Services Plan and is required to notify AHCo immediately of any deviation in the implementation relative to the plan approved by AHCo.

### 14.6.2 Maintenance Services Plan scope

The Maintenance Services Plan will include, among other things, all the tasks, operation plans, logistics plans and work plans required for the provision of Maintenance Services, including:

14.6.2.1 Status and monitoring of all types of licensing in all the sub-systems, expected renewal dates, dates and subjects of expected audits and surveys.

14.6.2.2 Management and monitoring status of all types of agreements with sub-contractors and service providers.

14.6.2.3 Lists of all Technical Staff required to execute the Maintenance Services.

14.6.2.4 Preventive Maintenance actions and schedule.

- 14.6.2.5 Actions required for creating functional continuity in cases of critical Malfunctions/faults.
- 14.6.2.6 Procedures and schedule for updating and upgrading of MUTC components and related services and tools provided by the Supplier.
- 14.6.2.7 Drills, training, courses, and refreshers which are required for the Supplier's staff and AHCo maintenance staff.
- 14.6.2.8 QA audits.

## 14.7 Adaptive maintenance – MUTC Updates

14.7.1 The Supplier is responsible for applying updates to the MUTC (including MUTC components and related services and tools provided by the Supplier).

In addition, the Supplier is responsible for applying updates to the Adaptive Field Equipment and any Outstation Devices the Supplier provided.

14.7.2 Trigger events for applying updates

Updates to the MUTC will be made at least in the following cases (hereinafter: “**Update Events**”):

- 14.7.2.1 Updates of software version, according to the manufacturers’ requirements.
- 14.7.2.2 Updates of the operating systems.
- 14.7.2.3 Firmware updates.
- 14.7.2.4 Security events.
- 14.7.2.5 Update of the interfaces to other external systems.
- 14.7.2.6 When discovering a bug in the MUTC - see Corrective Maintenance.
- 14.7.2.7 Updating the MUTC network and system configuration, as required, to comply with OT network and cybersecurity requirements, including, for example, changes to VLANs, IP addresses, and security configurations
- 14.7.2.8 3rd Party Software updates - For the purpose hereof, “3rd Party Software” means all computer programs, whether in electronic read-only devices, cloud services or otherwise, including operating systems, data, and utilities, supplied without modification by a 3rd party software publishing house installed and/or supplied as part of the MUTC and its associated documentation.

14.7.3 Maintenance Services and Update Event

In any Update Event, the Supplier will continue to provide the Maintenance Services in connection with at least the version of the software that is currently installed as part of the MUTC. If any Update Event is implemented, such Update Event will thereupon be deemed to be part of the MUTC.

14.7.4 The implementation date of an Update Event.

- 14.7.4.1 The Supplier will coordinate any Update Event installation with AHCo.
- 14.7.4.2 The Supplier must implement the updates in such a way that the software, and firmware will be in the most updated version, and this within 90 days from the date of publication of the latest software version by the relevant manufacturer.
- 14.7.4.3 However, AHCo may demand staying with the existing version for a period of up to 3 years, from the date of publication of the Update Event.
- 14.7.4.4 Notwithstanding anything to the contrary contained herein, AHCo can require the Supplier to postpone an Update Event, in cases that it may affect AHCo’s use of the MUTC or impose any undue burden on AHCo.
- 14.7.4.5 The Update Events will be integrated into the Maintenance Services Plan, as described in section 14.6 above.

14.7.5 Applying Update Events

- 14.7.5.1 The Supplier will provide AHCo with prior written notice (as soon as practicable but in no event less than 10 days, or a shorter period as required for urgent error-correction approved by AHCo), of the Update Events.

- 14.7.5.2 The Supplier will provide such an Update Event to AHCo with necessary licenses, detailed instructions concerning installation; detailed preparation and pre-requisite instruction; tests to assure the functionality and operability; and update impact; all at no additional cost to AHCo.
- 14.7.5.3 All Update installations will be subject to ATP and a Regression Test Plan, that shall be approved by AHCo. Furthermore, the Supplier shall prepare a modification plan document which will contain all the modifications to be performed and the reasons for such modifications, for the approval of AHCo.
- 14.7.5.4 The Supplier shall also prepare a risk and mitigation plan document which will be delivered to AHCo.
- 14.7.5.5 Updates will be performed in a stage approach, first in the non-production environment, and only after successful tests, in the operational environment.
- 14.7.5.6 The update procedure will always include a rollback procedure in case of failure.
- 14.7.5.7 An update procedure will always have a backward compatibility document to all MUTC operational aspects and interfaces.
- 14.7.5.8 An Update installation is completed only after acceptance and after all the following:
  - 14.7.5.8.1 The Supplier performs a series of tests to ensure the software's operability.
  - 14.7.5.8.2 All test measurements were documented and delivered to AHCo.
  - 14.7.5.8.3 AHCo supplied the Supplier with a certification document that states that the update installation is completed and accepted.
  - 14.7.5.8.4 Training rounds for the MUTC users and updates to the MUTC documentation.
- 14.7.6 EOS/EOL
  - 14.7.6.1 If a component is declared as its end of life and/or end of support and/or end of sale, the Supplier will immediately alert AHCo and propose an alternative component for approval.
  - 14.7.6.2 The alternative will be a solution that does not impair the operation of the MUTC and has at least equivalent or superior capabilities to the current component.
  - 14.7.6.3 The alternative product shall be compatible with the existing software, firmware, and physical mounting arrangements, and shall not require additional adapters, modifications, or cost to AHCo, unless otherwise approved by AHCo.
  - 14.7.6.4 The replacement product shall not be expected to reach its own End of Life (EOL) within less than three (3) years from the date of its approval by AHCo.
  - 14.7.6.5 AHCo may require the Supplier to provide supporting documented evidence regarding the proposed replacement component, including data sheets, manufacturer documentation, test reports, and lab reports, for review. AHCo may also require the Supplier, at no additional cost, to perform tests necessary to demonstrate the operability and suitability of the replacement component in a laboratory environment.

## 14.8 Preventive Maintenance

- 14.8.1 Preventive Maintenance Services
  - 14.8.1.1 The Supplier will perform preventive Maintenance Services for the MUTC, the Adaptive Field Equipment, and Outstation Devices provided by the Supplier (hereinafter: "**Preventive Maintenance**").
  - 14.8.1.2 Preventive Maintenance will be performed in accordance with the instructions of the relevant manufacturers.
  - 14.8.1.3 The Preventive Maintenance services will be performed according to the Maintenance Services Plan, as described in section 14.6 above.
  - 14.8.1.4 At the end of each Preventive Maintenance execution, the Supplier will submit a summary report to AHCo.
- 14.8.2 Preventive Maintenance will include:
  - 14.8.2.1 Load tests.
  - 14.8.2.2 Testing interfaces to external systems.
  - 14.8.2.3 Compliance with security requirements.

- 14.8.2.4 Database maintenance according to industry best practices.
- 14.8.2.5 Clearing memory, cache data and free storage in virtual machines, devices, dockers, computers, etc.
- 14.8.2.6 Checking the monitoring state (Is the service or device is monitored and what is monitored).
- 14.8.2.7 Checking logs for errors.
- 14.8.2.8 Running Application continuity and redundancy tests.
- 14.8.2.9 Recovery from backup tests.
- 14.8.2.10 Calibration of Adaptive Field Equipment.
- 14.8.2.11 Adaptive Field Equipment maintenance according to industry best practices.
- 14.8.2.12 Preparations for the Adaptive Field Equipment for winter.

14.8.3 Preventive Maintenance Services annual plan

As part of the Maintenance Services Plan, the Supplier shall prepare and implement an annual Preventive Maintenance plan, which shall include the actions listed below. The Supplier may propose additional preventive maintenance actions, subject to AHCo’s approval, as part of the Maintenance Services Plan described in Section 14.6 above.

Maintenance activities relating to servers and workstations in the MUTC environments shall be performed in coordination with AHCo’s IT maintenance team. AHCo’s IT maintenance team shall be responsible for the underlying IT infrastructure and standard enterprise IT maintenance activities, while the Supplier shall perform the maintenance activities related to the MUTC application, its supporting software components, and any Supplier-provided configurations, services, or tools. The detailed schedules for such maintenance activities shall be defined in coordination with AHCo and in accordance with AHCo’s applicable maintenance schedules and operational constraints.

#	Element	Frequency of action	Action to perform	Example actions
1.	Servers and Workstations in each environment (Prod, non-prod, every site)	Once a year	Building a work plan for updating system versions, infrastructures, and supporting systems	Mapping of all system components and their versions. Mapping and building a work plan for updating component versions. Implementation of the plan on an annual level.
2.	Servers and Workstations in each environment (Prod, non-prod, every site)	Once a month	Version updates and security updates	Check version of each element and applying update of software and firmware versions (patch, service pack, etc.).
3.	Servers and Workstations in each environment (Prod, non-prod, every site)	Once a month	Checking data storage components such as - Storage - Virtual server drives - Physical disks in servers, workstations - Backup disk/tapes	Data storage integrity check. Checking the data accumulation rate and a sample check of the stored data. Checks that the data repositories are not filling up. Utilization of storage system resources will not exceed 90% (RAM, CPU, storage) Storage capacity on virtual servers will not exceed ninety percent (90%)
4.	Servers and Workstations in each environment (Prod, non-prod, every site)	Once a month	Database integrity check	Checking the integrity of data storage. Checking database logs for errors. Checking index fragmentation. Checking redo log queue size.

#	Element	Frequency of action	Action to perform	Example actions
				<p>Checking the integrity of replicas,  Checking the integrity of jobs.  Checking server resource utilization (CPU, RAM, ROM),  Monitoring the number of connections to database servers and their status.  Identifying queries that can be improved</p>
5.	Servers and Workstations in each environment (Prod, non-prod, every site)	Once a month	Communication check	<p>Perform a check of network integrity and traffic loads in the network, such as Latency, Bandwidth Utilization, Packet loss Error Rates.  Create a baseline of network metrics in a normal configuration and compare the network state to the baseline.  Check bandwidth between sites and their utilization level.</p>
6.	Servers and Workstations in each environment (Prod, non-prod, every site)	Once a month	Virus check	<p>Checking the update status of the antivirus database signatures on all servers and workstations.  Checking that the agent is functioning correctly on the workstations and servers.  Checking critical alerts.  Removing threats from all computers and workstations.</p>
7.	Servers and Workstations in each environment (Prod, non-prod, every site)	Every quarter	Evaluating the ability to restore the system from the backup infrastructure.	Performing a sample test to restore a server or system data from the backup server.
8.	Servers and Workstations in each environment (Prod, non-prod, every site)	Every half year	Evaluating the ability to restore the system from an external backup tape.	Performing a sample test to restore server or system data from a tape backup.
9.	Servers and Workstations in each environment (Prod, non-prod, every site)	Once a month	Monitoring infrastructure inspection	<p>Check that the topology of the monitored components matches the system configuration in each environment.  Check that all system components are monitored and send logs to the system.  Check and update thresholds and metrics of the performance of the various services.</p>
10.	Continuity architecture	1-3 drills a year	Readiness check of the DR and transition to DR site	Physical participation in exercises at customer sites, support in transitioning system operations from main site to DR site and back.
11.	Servers and Workstations in each	Once a year	Electrical backup testing for servers	Assistance in exercises at customer sites to test electrical backup for servers.

#	Element	Frequency of action	Action to perform	Example actions
	environment (Prod, non-prod, every site)			
12.	Servers and Workstations in each environment (Prod, non-prod, every site)	Once a year	Cyber tests	Assistance and participation in system cyber survey tests performed by or on behalf of AHCo.
13.	Servers and Workstations in each environment (Prod, non-prod, every site)	Once a year	Cyber tests	Assistance and support for system penetration tests performed by AHCo or on its behalf.
14.	MUTC application	Every quarter	Checking the integrity of the application	On each server of the system, make sure that all services are active. Make sure that all services are monitored in the monitoring suite. Check application logs and locate error messages. In the event of errors, analyze and treat them as failures.
15.	Interfaces with external system	Every half year	Interface connectivity health check	Mapping of all active interfaces. For inactive interfaces, make sure that the connectivity settings for them have been canceled (FW rules, network routing, application services) Make sure that for active interfaces there is proper communication. For each interface, analyze the logs and check that there are no log errors. If there are errors, analyze and treat them as faults.
16.	Outstation Devices	Once a year	General maintenance	Testing and implementing manufacturer's instructions for preventive maintenance for all types of hardware components.
17.	Outstation Devices	Once a year	Version updates and security updates	Testing and ongoing updating of software and firmware versions (patch, service pack, etc.).
18.	Outstation Devices	Every half year	Physical check at each site	Checking signage, marking cables and connections in the network - bundling, channeling and completion as needed. Checking integrity of the construction, installation, and electricity. Checking and treatment for the presence of rodents, such as verifying the integrity and replacing eaten cables. Checking the registration of the equipment according to the inventory. Updating the site documentation. verifying doors of the enclosures are closed.

#	Element	Frequency of action	Action to perform	Example actions
19.	Outstation Devices	Once a year	Cyber tests	Assistance and participation in system cyber survey tests performed by or on behalf of AHCo.
20.	Outstation Devices	Once a year	Cyber tests	Assistance and support for system penetration tests performed by AHCo or on its behalf.

*Table 27 - Preventive maintenance annual plan*

## **14.9 Continuous management and monitoring of the MUTC cloud's infrastructure, services and tools**

### **14.9.1 Management and monitoring of MUTC cloud installation**

14.9.1.1 This section shall apply only if a MUTC cloud configuration — either hybrid or full — is ordered by AHCo.

14.9.1.2 The Supplier will be responsible for continuous monitoring of the MUTC cloud infrastructure and services which support the MUTC operation. The monitoring will include 24/7 supervision of all MUTC cloud services to ensure that it meets the requirements of the MUTC components which are hosted in the cloud.

### **14.9.2 Scope of work**

The continuous MUTC cloud monitoring will include (but is not limited to) the following:

14.9.2.1 Monitoring cloud environment: This involves 24/7 monitoring and tracking of all MUTC cloud layers and tools, using a COTS tool, which may include the CloudWatch or equivalent service, to ensure MUTC smooth and continuous operational functionality.

14.9.2.2 Continuous status updates and sending log files to the Supplier's NOC (NOC deployed in the Supplier's maintenance center that monitors all MUTC layers).

14.9.2.3 Identifying and addressing performance / MUTC service failures and failures risks: This involves (but is not limited to) identifying and addressing performance degradations, increased latencies, reaching database capacity thresholds, reaching cloud storage and bandwidth thresholds and more.

14.9.2.4 Automatic alert notification: The Supplier shall perform continuous online parsing of the log files, to identify alerts that were designated as such that require an immediate resolution. Once such alerts are identified in the log, an immediate notification/email will be sent to the maintenance teams (both the Supplier and AHCo) and will automatically open a ticket in the maintenance ticketing system.

### **14.9.3 Periodic management of cloud infrastructure.**

The Supplier will be responsible for the periodic management of cloud infrastructure, which will include monitoring, evaluating, and optimizing cloud infrastructure to ensure that it meets the requirements of the MUTC and is compliant with industry best practices. The periodic management will include the following, but is not limited to:

14.9.3.1 Monitoring cloud resource usage: This involves tracking the usage of cloud resources, such as CPU, memory, storage, and network bandwidth. This information can be used to identify areas where resources are being underutilized or overutilized. The Supplier will monitor the cloud resources & performance using a COTS tool (such as AWS CloudWatch). The selected tool shall be approved in advance by AHCo.

14.9.3.2 Reviewing cloud infrastructure costs: This involves reviewing cloud spending to identify areas where costs can be reduced. This can be done by optimizing resource usage.

14.9.3.3 Identifying and addressing security risks: This involves identifying and addressing security vulnerabilities in the cloud infrastructure. This can be done by regularly scanning the cloud environment for vulnerabilities and implementing appropriate security measures.

14.9.3.4 Keeping cloud infrastructure up to date: This involves applying security patches and updates to cloud resources and services to ensure that they are secure and up to date.

## 14.10 Performance-Based SLA for adaptive intersection management

### 14.10.1 Intent and scope

AHCo intends to track and enforce a specific SLA regarding the operational effectiveness of adaptive traffic light management. The objective is to ensure that the adaptive algorithms provided by the Supplier deliver measurable improvements in traffic flow compared predefined scheduled Traffic Light Timing Plans.

### 14.10.2 POC and parameter definition phase

During the initial Proof of Concept (POC) for centralized adaptive management (as defined in Section 4.8.19), AHCo and the Supplier shall collaboratively define the final set of measured parameters and target thresholds. These parameters may include, but are not limited to:

- Average travel time: Comparison of segment travel times via Waze or strategic detectors.
- Intersection throughput: Increase in the number of vehicles cleared per cycle.
- Queue length reduction: Decrease in maximum observed queue lengths.
- Pedestrian LOS: Ensuring wait times do not exceed defined maximums during adaptive adjustments.

### 14.10.3 Adaptive stabilization period

AHCo recognizes that for each Signalized Intersection, the adaptive algorithms require a "learning" or "settling" phase to optimize for local traffic patterns.

- Duration: For each Signalized Intersection, a stabilization period of sixty (60) days will be granted upon the activation of the centralized adaptive module at any new intersection.
- Supplier Obligations: During this period, the Supplier shall actively monitor, calibrate, and fine-tune the system. The Supplier will provide bi-weekly optimization reports.

### 14.10.4 Comparison and effectiveness benchmark

Following the stabilization period, the centralized adaptive module effectiveness will be measured against the Standard Management Baseline (historical data for the same day type and time interval).

- The adaptive system must demonstrate a statistical improvement (to be quantified during the POC) over the baseline.
- If the adaptive management results in a degradation of traffic flow compared to the predefined scheduled Traffic Light Timing Plans, it will be considered a performance breach.

### 14.10.5 Supplier responsibility and compensation

The Supplier bears full responsibility for the performance of the adaptive logic.

- Remediation: If the system fails to meet the agreed-upon SLA targets after the stabilization period, the Supplier shall have 30 days to rectify the logic at no additional cost to AHCo.
- Compensations: Failure to achieve the "Better Performance" threshold after the remediation period will trigger liquidated damages.

## 14.11 Extended warranty, knowledge transfer, and calibration of adaptive intersections

### 14.11.1 Support period and technical responsibility

Notwithstanding any other provision of this Agreement, for each intersection added to the Adaptive Management Module, the Supplier shall bear full responsibility for the management of that specific intersection for a period of 12 months commencing on the date that such intersection is successfully activated for operational use following completion of the applicable POC activities. During this 12-month period, the Supplier shall be responsible for:

#### 14.11.1.1 Continuous monitoring of the performance of each specific Signalized Intersection managed by the centralized adaptive management module.

14.11.1.2 Execution of all required calibrations and adjustments to maintain the applicable SLA level and improve it to the maximum extent practicable.

14.11.1.3 Resolution of any malfunctions arising from the system's behavior in varying field conditions.

#### 14.11.2 Knowledge transfer and training

For each specific intersection added to the Adaptive Management Module, the Supplier shall, upon completion of the 12-month responsibility period, carry out a structured knowledge-transfer and training process for the AHCo professional team. The purpose of this process is to transfer the unique operational and traffic characteristics of that specific intersection required to support effective future calibration by AHCo. For the avoidance of doubt, the Supplier's responsibility under this Section is limited to aspects related to the adaptive operation of the intersection. Calibration, maintenance, and proper operation of detectors supplied by the Supplier shall remain under the Supplier's responsibility in accordance with the Contract.

#### 14.11.3 Transition to AHCo-Led Calibration

14.11.3.1 Upon completion of the Support Period and the AHCo team is trained, responsibility for ongoing routine calibrations shall transition to AHCo.

14.11.3.2 The practical calibration will be performed by the AHCo team (or their representatives) as part of the readiness process for the eventual handover of the system to AHCo.

14.11.3.3 Following the transfer of calibration authority, the Supplier shall continue to provide technical support for infrastructure and software layers as part of the general Maintenance Agreement.

#### 14.11.4 Performance liability during the transition period

For each Signalized Intersection managed by the centralized adaptive management module, the Supplier remains solely responsible for the performance of the Signalized Intersection throughout the entire 12-month Support Period. If, during this period, it is demonstrated that a failure to meet targets results from faulty calibration performed by the Supplier or ineffective adaptive algorithm, the compensation mechanisms defined in the SLA chapter shall apply.

## 14.12 Backup and recovery

The full backup procedure of the MUTC servers will be performed periodically by AHCo. Any specific applicative backup, including database backup, needed for the MUTC operation will be performed separately by the Supplier.

#### 14.12.1 Recovery tests

The Supplier shall perform recovery tests as described below:

14.12.1.1 Annually recovery test: The Supplier must perform an annual recovery test to ensure that the backups can be restored successfully and submit a test report for the approval of AHCo. AHCo may, upon its sole discretion, participate in the annual restore test.

14.12.1.2 Recovery verification: The Supplier must verify that all system data can be accessed and used successfully.

14.12.1.3 Recovery test report: The Supplier must provide a report of the recovery test results.

## 14.13 MUTC components' maintenance responsibility

#### 14.13.1 Responsibility for the maintenance of the system components

The responsibility for the maintenance of the system components installed in AHCo's local infrastructure (On-premises) will be divided between the Supplier and AHCo as detailed below:

Component	AHCo	The Supplier
IT Infrastructure	Full responsibility	
Communication infrastructure	Full responsibility	
MUTC application		Complete responsibility

		Events notification to the AHCo NOC and AHCo Tier 1
Monitoring	IT and communication infrastructure (on-prem & cloud)	MUTC application & cloud infrastructure services.
Backup and recovery	Regular periodic backups of the production environment at the DR site. Coordination of recovery procedures.	Performing restorations and checking the backup information. Recovery actions for MUTC and other supplied services and tools. Assistance in recovery procedures related to other parties.
Cyber Security	Firewall, Permissions management	Vulnerabilities of application, services and tools supplied by the Supplier. Assistance as required in tests and required actions.
SOC	Receiving alerts from the company's SOC, analysis, performing derivative actions	Events notification to the SOC. Assistance as required in tests and other required actions.
APN communication infrastructure for the traffic light systems	Full responsibility, unless APN is ordered as workload	If the APN service is ordered as workload, then the Supplier is fully responsible for ordered APN.
Signalized Intersection equipment like Traffic Light Controllers, light bulbs, detectors, UPS, cabinet, pushbuttons, etc. Not including Adaptive Field Equipment.	Full responsibility.	
Adaptive Field Equipment		Fully responsibility

*Table 28 – Maintenance responsibility*

#### 14.13.2 Environment responsibility

The division of responsibility as detailed above will apply both to the production and non-production environments.

#### 14.13.3 Assistance to AHCo

It will be clarified that despite the division above, the Supplier must perform any action to assist and improve the Maintenance Services for the On-Premises infrastructure. Including assistance to AHCo during events, providing professional advice, etc.

### 14.14 Quality assurance

#### 14.14.1 Compliance with all quality procedures

During the provision of the Maintenance Services, the Supplier shall comply with all quality procedures, as detailed in the SOW in section 11.3.2. Any fix, Work-Around, or action that the Supplier will perform as part of the Maintenance Services, shall have a test procedure and the required regression tests to be performed. The required tests shall be first performed within the MUTC staging environment, and only after successful completion may changes be uploaded to the MUTC operational environment.

#### 14.14.2 Any deviation from the quality procedures must be approved in advance by AHCo.

## **14.15 Ongoing training sessions for MUTC users**

### **14.15.1 Additional Training during the Warranty Period**

In addition to the training sessions conducted during the installation / trial-run period, the Supplier will provide 20 days of training during the Warranty Period and the first year of the Maintenance Period, and up to 10 days for the next operating year, as required by AHCo, at the AHCo site or by remote training sessions if approved by AHCo.

### **14.15.2 Coordinating of the additional Training**

AHCo will coordinate the dates and content as needed - operator training, technical training, administration training, or any topic that requires further knowledge. The Supplier is responsible for providing a training facility, training tools, training environments, and all relevant materials and documents for the training sessions.

## **14.16 Functional Continuity and Recovery from Extreme Situations**

### **14.16.1 Definition of an extreme situation**

An extreme situation is any event that can disable the MUTC operation and cannot be resolved within the defined maintenance SLA. AHCo may require the Supplier to add situations deemed by AHCo to be extreme situations.

### **14.16.2 Functional continuity plan**

14.16.2.1 The Supplier shall participate in the design of the “Functional Continuity and Recovery from Extreme Situations” plan, in collaboration with AHCo, and shall support its preparation.

14.16.2.2 The Supplier's employees or anyone on his behalf will participate in AHCo internal surveys, training, drills, refreshers and preparation for extreme situations whenever occur.

14.16.2.3 Updating the plan will be carried out after recovery from extreme situations according to changes or insights that arise after the drills, including comparing the plan versus performance, lesson learning and implementation.

### **14.16.3 The plan**

The plan will include the following, among other things:

14.16.3.1 Mapping all the work processes and the infrastructure of the MUTC, and their support resources to maintain functional continuity of the MUTC and recover from an extreme situation.

14.16.3.2 Definition of clear parameters, roles and responsibilities for maintaining functional continuity and recovery from extreme situations.

14.16.3.3 Crisis management process and the readiness for action/response according to defined parameters.

14.16.3.4 Describing the ongoing method of managing and updating the plan for functional continuity and recovery from extreme situations.

### **14.16.4 Annual DR test:**

The Supplier must coordinate with AHCo and perform at the end of each calendar year, an annual continuity and recovery from extreme situations test to ensure that the process and procedures are fully operational and submit a test report for the approval of AHCo. AHCo may, upon its sole discretion, participate in the annual continuity and recovery from extreme situations test.

## **14.17 Maintenance Services in Emergency Situations**

The Supplier acknowledges that the MUTC is a mission-critical operational system. Accordingly, during any emergency period, including war or security-related events, the Supplier shall continue providing the Maintenance Services in full, and the SLA defined in this SOW shall remain unchanged and fully

binding, unless AHCo instructs otherwise in writing. The Supplier shall ensure in advance all organizational, technical, and logistical preparedness necessary to meet these obligations.

## **14.18 Maintenance Support Center**

### **14.18.1 Maintenance Support Center**

The Supplier shall establish a Maintenance Support Center (including a Help desk) for the MUTC (hereinafter: “**Support Center**”).

### **14.18.2 Support Center responsibilities.**

The Support Center shall provide a response to any support request for functional, operational, or procedural process or any kind of designated problem within the MUTC, including (but not limited) the following issues:

- 14.18.2.1 Guidance and assistance in using all MUTC capabilities for all MANTAM personnel, who use the MUTC.
  - 14.18.2.2 The setting of metrics, LOS and thresholds for warnings and initiation of Response Plans.
  - 14.18.2.3 The setting of rules for the DSS module and for the Traffic Events module.
  - 14.18.2.4 Configurations for the Traffic Events module, including defining new types of Traffic Events and Response Plans.
  - 14.18.2.5 Setting new roles and additional clients.
  - 14.18.2.6 Configurations of displays for different operators.
  - 14.18.2.7 Defining relevant displays according to the role of the operator.
  - 14.18.2.8 Setting geographical area of interest.
  - 14.18.2.9 Setting all layers and entities to be displayed.
  - 14.18.2.10 Defining all relevant rules related to the area.
  - 14.18.2.11 Configuration of relevant interfaces to external systems.
  - 14.18.2.12 Setting any required privileges for the operator.
  - 14.18.2.13 Assistance with problems and Malfunctions in the MUTC system, its infrastructure and in any Adaptive Field Equipment or Outstation Devices provided by the Supplier. The Support center will open ticket for malfunctions, bugs, support and maintenance issues in the ticketing tool.
  - 14.18.2.14 MUTC users' permissions setup to the system.
  - 14.18.2.15 Defining Signalized Intersection.
  - 14.18.2.16 Managing Signalized Intersection.
  - 14.18.2.17 Managing sub-network of Signalized Intersection.
  - 14.18.2.18 Managing predefined Response Plans.
  - 14.18.2.19 Using the priority modules.
  - 14.18.2.20 Using and applying adaptive traffic management on Signalized Intersections.
- ### **14.18.3 Support Center customers**
- 14.18.3.1 Currently, there are about 20 staff members at each MANTAM, including shift managers, system engineers, traffic engineers, administrators, and AHCo managers.
  - 14.18.3.2 Representatives of AHCo Information Systems Division.

14.18.3.3 The Supplier is not expected to respond to calls and cooperate with 3rd parties such as municipal authorities' representatives, road services providers and emergency forces, unless specifically asked by AHCo suppliers, traffic operators' partners and organizations. The Supplier shall inform the relevant 3rd party, in advance, if possible, if its work will affect the operation of systems or services which are under the responsibility of the 3rd party, for example, Malfunctions which influence interfaces between the MUTC and external traffic system.

#### 14.18.4 Support Center concept of operation

The Support Center will be managed in a "Tiers concept", providing a "single point of contact" integrated support for all MUTC components.

14.18.4.1 Tier 1 – Will be delivered by the (as detailed above) which will perform first-level analysis to any opened case/issue and respond whether with an answer or a decision to propagate it forward to the Tier 2 team.

14.18.4.2 Tier 2 – Tier 2 staff will include highly trained technical personnel, who will have the ability to further investigate and analyze the opened case/issue and to respond whether with an answer, Work-Around and RCA or with a decision to propagate it forward to Tier 3 team.

14.18.4.3 Tier 3 – Tier 3 staff will include R&D expert personnel in all relevant aspects, that are well familiar with the MUTC and its modules. Tier 3 staff will have the ability to resolve any inquiry/issue that Tier 2 was unable to solve to perform a thorough analysis and offer a Work-Around, find the root cause and offer a long-term solution to an issue.

#### 14.18.5 Support Center Technologies

14.18.5.1 Chatbot tool – This shall include an automatic, best-of-breed COTS chatbot tool, that will be configured in an ongoing manner by the Supplier's support team to answer various questions and will be the first line of operations support for AHCo's operations personnel.

#### 14.18.5.2 Support Center tools –

14.18.5.2.1 The Supplier will operate the Support Center based on AHCo's internal maintenance system (HxGN EAM).

14.18.5.2.2 The Supplier will receive appropriate authorizations to perform operations in AHCo's maintenance system.

#### 14.18.6 Contact channels for the Support Center

14.18.6.1 The Supplier shall provide AHCo with a designated local Israel telephone number and WhatsApp number.

14.18.6.2 The Supplier shall ensure that a designated number shall be allocated for AHCo Maintenance Services only.

14.18.6.3 In addition, it will be possible to contact the Support Center via e-mail.

#### 14.18.7 Support Center staff

14.18.7.1 The Support Center shall be operated by personnel, which are qualified to provide the Maintenance Services. The Supplier shall provide AHCo with a written list of the names of the key members in the Support Center and their contact information.

14.18.7.2 The number of service representatives will be determined by the Supplier in a way that corresponds to the service levels detailed below.

14.18.7.3 The Supplier will nominate a Support Center point of contact (POC) within its staff, who will be responsible for opening Support Center cases and communicating with the Supplier's Support Center staff.

14.18.7.4 As a rule, Support Center services and related communications will be in the Hebrew language, unless AHCo, in its sole discretion, will decide differently.

#### 14.18.8 Required response times in the Support Center:

14.18.8.1 The Support Center will be available 24 hours, 7 days a week.

14.18.8.2 For each application, an automatic message (support ticket) will be sent to the AHCo tier 1, confirming the date of receipt of the application and updating the applicant on the expected duration of treatment 24 hours a day, 365 days all year long. In addition, Maintenance Events shall be updated, by the Support Center, in the HxGN EAM platform.

#### 14.18.9 Operating instructions in case of inquiries to the Support Center:

- 14.18.9.1 The Supplier will be required to open a ticket for every inquiry that arrives at the Support Center, which will include a record of the received time, the identity of the applicant, contact details, type of referral, evaluation of response time, actions, and methods used to answer.
- 14.18.9.2 The Supplier will be required to present to AHCo flow charts for call scenarios for each scenario listed in section 14.18.2. The flow charts will include predicted FAQs, the escalation process between Tiers, and the procedure for closing an inquiry.
- 14.18.9.3 The Supplier will also be required to present the manner in which the Support Center is supposed to meet the requirements in this section.
- 14.18.9.4 All the scenarios listed will be used as a part of the training materials for the Support Center staff.
- 14.18.9.5 In the event that an inquiry is defined as a Malfunction - the Support Center will manage the inquiry in accordance with what is detailed in section 14.19 below.
- 14.18.9.6 The Support Center is obligated to furnish the MANTAM operation staff with instructions on how to resolve any other events, that are associated with the MUTC operation, within a maximum timeframe of 24 hours.

## 14.19 Corrective Maintenance

### 14.19.1 Definitions:

- 14.19.1.1 **Defect** – A defect means a loss or any degradation of a non-critical capability which causes a minor performance degradation and capabilities.
- 14.19.1.2 **Failure** – any failure which causes a system crash, safety issue, or a major degradation of system performance and capabilities or the system doesn't meet the defined requirements.
- 14.19.1.3 **Malfunction** – Failure or Defect.
- 14.19.1.4 **Work-Around** - means a temporary solution, patch, or bypass supplied by the Supplier in order to temporarily correct, fully or partially, the Malfunction, in Severity 1 or 2.
- 14.19.1.5 **Maintenance Event** – refers to any anomaly behavior of the MUTC due to Malfunction or any other anomaly which causes any degradations of performance and capabilities.
- 14.19.1.6 **Severity Level** –
  - 14.19.1.6.1 **Severity Level 1** – Critical impact: System crash; security issue; Signalized Intersection failure caused by Adaptive Field Equipment or the MUTC.
  - 14.19.1.6.2 **Severity Level 2** – Severe impact: Loss or major degradation of a critical capability; significant performance degradation; failure of Outstation Devices supplied by the Supplier.
  - 14.19.1.6.3 **Severity Level 3** – Medium impact: Loss or major degradation of a non-critical capability; minor performance degradation.
  - 14.19.1.6.4 **Severity Level 4** – Low impact: Minor non-critical capability degradation; operator inconvenience; slight imperfection.

The Supplier will provide a list of potential MUTC Malfunctions at the PDR to establish the defined severity level of each Malfunction. The definition of level of severity for each Malfunction will be defined after the approval by AHCo. AHCo and the Supplier will employ this list to assess the severity of Malfunctions as they occur.
- 14.19.1.7 **Malfunction Notice** - notice to the Supplier of a Malfunction.
- 14.19.1.8 **Root Cause Analysis (RCA) Time** – means the time interval from the RCA initiation to the Supplier's identification of the Malfunction root cause.
- 14.19.1.9 **Response Time** - means the time interval starting on Malfunction Notice and ending at the start of the RCA time.
- 14.19.1.10 **Correction Time** – means the time interval from the start of the RCA time until the Malfunction was fully fixed or the Malfunction severity was reduced and the system has returned to a full or partial operation whether by the implementation of a final resolution or by an implementation of a temporary Work-Around correction.

14.19.1.11 **Solution Time** – means the time interval from the start of the RCA time until the Malfunction was fully fixed and the system has returned to be fully operational and meets the required MUTC specification in full. The solution is fully integrated within the MUTC current release as the implementation of a final resolution.

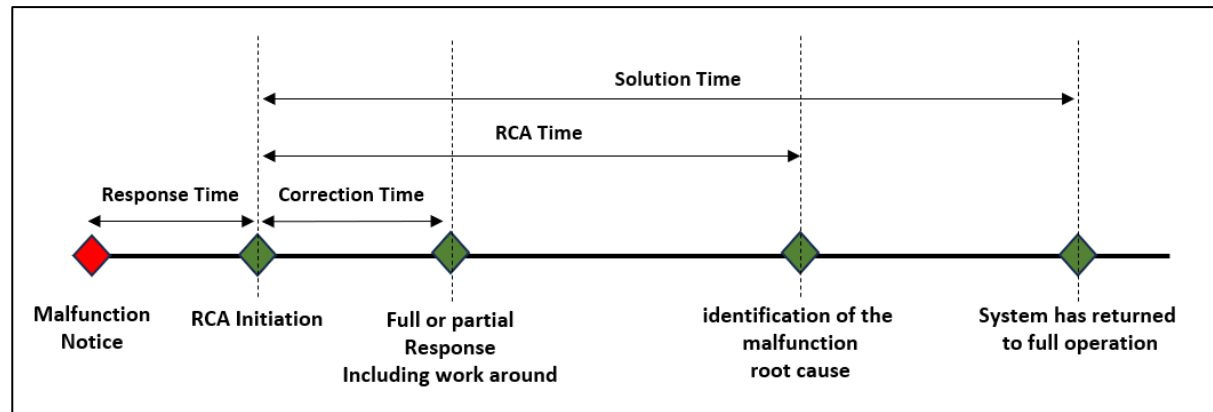

Figure 20 - Response and corrective time diagram

#### 14.19.2 Severity Levels and Response and Correction Times

14.19.2.1 The Response and Correction Times to any Maintenance Event shall be according to the Severity Level and the maximum SLA as described in the following table. Times (hours) for Severity Levels 1 and 2 are 365/24, whereas times (hours) for Severity Levels 3 and 4 refer to Business Days:

Severity Level	Maximum Response Time	Maximum Correction Time	Maximum RCA Time	Maximum Solution Time
Severity 1	One (1) hour	Two (2) hours	Twenty-four (24) hours	One (1) week
Severity 2	Four (4) hours	Four (4) hours	Forty-eight (48) hours	Two (2) weeks
Severity 3	Twelve (12) hours	Forty-eight (48) hours	One (1) week	One (1) month
Severity 4	Twenty-four (24) hours	One (1) week	Two (2) weeks	One (1) month

Table 29 - Maintenance SLA time

14.19.2.2 In the event of a dispute regarding the correct classification of Severity Levels, the final determination shall be made solely by AHCo at its sole discretion.

14.19.2.3 The SLA pertains exclusively to Maintenance Events that are under the responsibility of the Supplier (refer to section 14.13 for the specified responsibilities). In cases where the Malfunction is defined by another maintenance team (AHCo NOC, 3rd party supplier, etc.), the Supplier will only provide assistance with the resolution, if necessary. The response time for this support will be determined by the "Maximum Response Time" and the relevant Maintenance Event severity, as specified in the table above.

14.19.2.4 If the Supplier fails to meet the timeframes set out in the table above, it may be subject to the liquidated damages specified in Appendix E to the Agreement.

#### 14.19.3 General

- 14.19.3.1 The Supplier will repair and restore to operability any **Maintenance Event** of the MUTC.
- 14.19.3.2 A Maintenance Event will be carried out, in coordination with AHCo and other relevant parties, and under the management of the Support Center.
- 14.19.3.3 The following diagram reflects the Malfunction correction workflow which is executed by a collaboration of all relevant parties:
- 14.19.3.3.1 Supplier – The Supplier will be responsible for any Maintenance Event in the MUTC and will perform all corrective maintenance activities in accordance with the specified SLA. The Supplier will work collaboratively with the AHCo Tier 1 team and the AHCo NOC to fix the Malfunction\defect, perform all maintenance activities, and provide and receive updates on the status of the Maintenance Event until it is resolved.
- 14.19.3.3.2 AHCo Tier 1 – AHCo Tier 1 is responsible for the coordination of all maintenance team activities, beginning with the initiation of the Maintenance Event by opening a ticket in the maintenance management system, providing instructions to the maintenance teams, resolving any disputes between the teams, and finally closing the Maintenance Event after the final solution has been provided.
- 14.19.3.3.3 AHCo NOC– Any Malfunctions associated with the IT and communication infrastructure are the responsibility of AHCo NOC. The NOC will inform Tier 1 of any Malfunctions that are detected and will collaborate with the Supplier to resolve any infrastructure Malfunctions that affect the MUTC's operation. AHCo NOC will also provide Tier 1 with assistance in identifying the source of the Malfunction and resolving disputes between the maintenance teams.
- 14.19.3.3.4 MANTAM System engineer – The MANTAM system engineer will provide Tier 2 services and will assist Tier 1 in analyzing and identifying the source of the Maintenance Event and resolving disputes between the maintenance teams.
- 14.19.3.3.5 Cloud provider – The cloud provider will be involved in the event of a cloud services infrastructure Malfunction that affects the operation of MUTC. The Supplier will monitor the cloud infrastructures that are currently in operation for the MUTC. However, only the AHCo NOC will work with the cloud supplier to resolve the Malfunction. In certain circumstances, AHCo may request that the Supplier communicate directly with the Cloud provider to address specific Malfunction. (This configuration shall be implemented only if Option 8.7 is exercised)
- 14.19.3.3.6 Other 3<sup>rd</sup> party providers related to AHCo – AHCo Tier 1 and AHCo NOC will manage Malfunctions caused by external systems, infrastructure, and Outstation Devices, in conjunction with the relevant 3<sup>rd</sup> party provider. The Supplier will assist in fixing the Malfunctions as may be required.

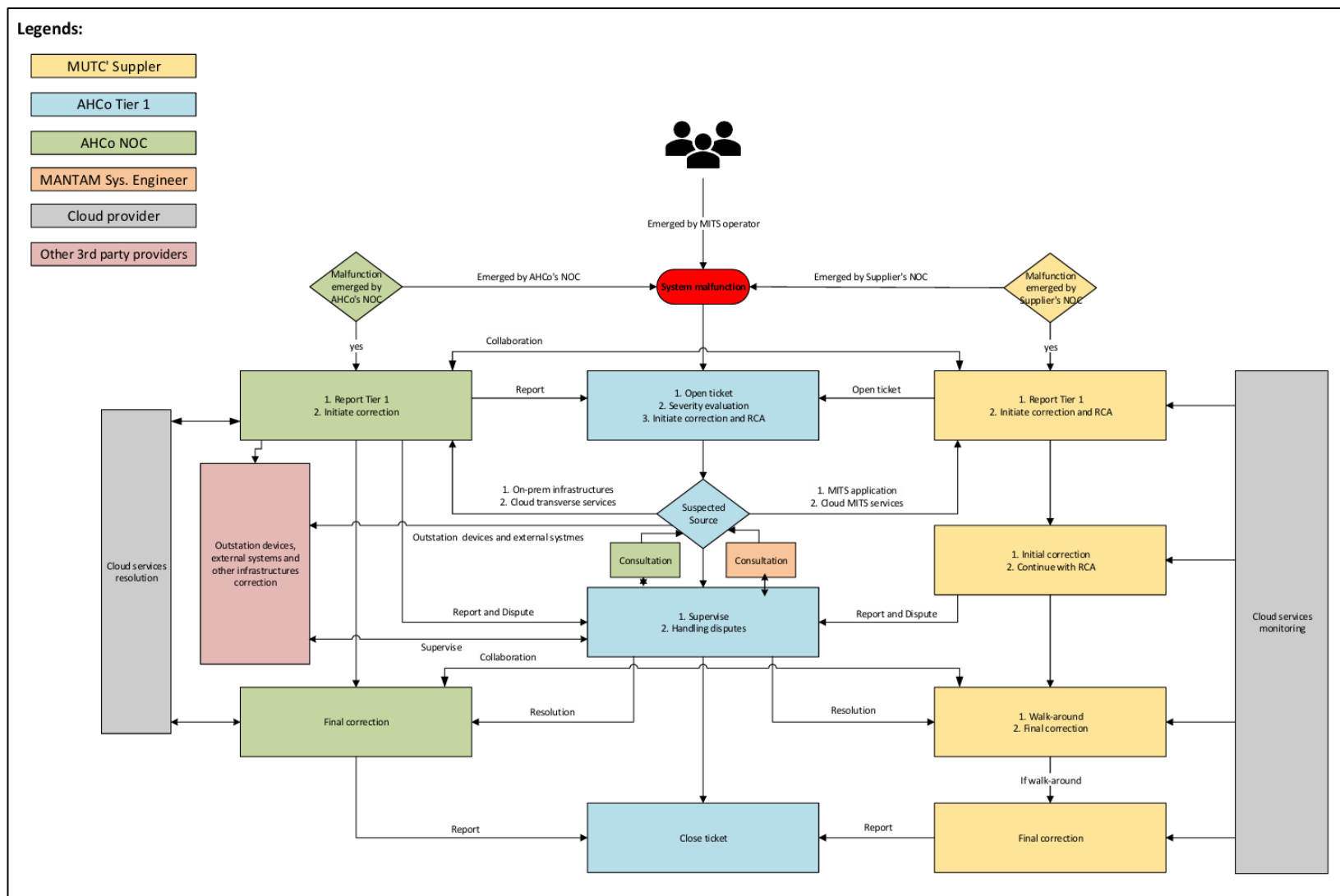

Figure 21 - Corrective maintenance framework

#### 14.19.4 Instructions for handling a Maintenance Event

- 14.19.4.1 For each Maintenance Event, the Supplier is required to submit the time estimate regarding the Response Time, RCA Times Correction Time and Solution Time.
- 14.19.4.2 The RCA time will not impact the required Correction or Solution Times specified above, so the Supplier must provide a solution prior to determining the root cause.
- 14.19.4.3 In cases where Maintenance Events, which are graded as Severity 3 or 4, cannot be repaired and resolved within the specified Correction Time, AHCo and the Supplier shall agree upon a date by which the Maintenance Event shall be repaired. In any event, such date shall not exceed 30 days from the Malfunction Notice .
- 14.19.4.4 If the Maintenance Event is not repaired and resolved by the agreed-upon date, the Maintenance Event classification shall be changed to Severity 2 and the Severity 2 Maximum Correction and RCA Times shall apply.
- 14.19.4.5 If the solution has not restored the MUTC to full operation but has only mitigated the Severity of the Maintenance Event, then the Supplier must continue resolving the issue in accordance with the revised severity level SLA.
- 14.19.4.6 Any Maintenance Services requiring MUTC downtime shall be subject to AHCo's prior written approval .
- 14.19.4.7 The Maintenance Event shall be considered resolved only after receiving the approval of AHCo.
- 14.19.4.8 The Supplier is required to check the repair of the Maintenance Event in the test environment before uploading the version to the production environment.

#### 14.19.5 Work-Around

In case the Supplier suggests a Work-Around to handle a Maintenance Event:

14.19.5.1 The Supplier shall request permission from AHCo to perform the temporary Work-Around and explain the reasons for this and the consequences of the Work-Around, for example, performance degradation.

14.19.5.2 AHCo may approve the request in a written document which will also include the maximum time for the completion of the full and final resolution of the Maintenance Event.

14.19.5.3 The Supplier may provide a Work Around solely subject to AHCo's prior written approval, and such Work Around shall not derogate from Supplier's obligation to provide a final resolution in accordance with an AHCo pre-approved time frame.

#### 14.19.6 Malfunctions in Outstation Devices provided by the Supplier

14.19.6.1 In the event of a malfunction to an Outstation Device provided by the Supplier, the Supplier will use the Spare Parts Inventory to replace the item to meet the maintenance SLA requirements. A functional replacement item will be provided at no additional cost. In this case, the supplier will bear all costs required to provide the replacement product as mentioned (including providing the replacement product, installing it, and removing the existing product at that time). See section 14.23.

14.19.6.2 In cases of recurring malfunctions - three (3) malfunctions of the same type within one hundred and twenty (120) consecutive days - the performing supplier will conduct a thorough inspection and, according to AHCo's decision, and if required, will replace all components needed for repair with new products.

#### 14.19.7 Remote Access by Supplier

14.19.7.1 In cases AHCo decides to enable the Supplier with a remote access functionality to the MUTC, the remote access will be done via DMZ and be aligned with AHCo's cybersecurity policies and permissions.

14.19.7.2 Subject to AHCo's prior written consent, and subject to the Supplier's confidentiality obligations, it may remotely log into the MUTC, solely for diagnosis, correction and installation, provided that:

14.19.7.2.1 The Supplier will access only the data and components of the MUTC required for the foregoing purpose and shall not access or collect any other information and/or systems or any part thereof; and

14.19.7.2.2 Any information obtained from such remote access will only be used by the Supplier to provide Maintenance Services. A violation or breach of the conditions of the paragraph above or this paragraph by the Supplier will be deemed a material breach of the Agreement.

14.19.7.2.3 The remote access tool will enable configuring access permissions up to the level of MUTC component/database or modules, define the allowed operations, and record and log the entire remote session.

#### 14.19.8 MUTC Maintenance Event documentation

14.19.8.1 The Supplier shall provide AHCo with details of the work being carried out in a Maintenance Event (e.g., day sheets, week sheets, work schedules). Documentation of all details will be provided by the Supplier in the HxGN EAM platform.

14.19.8.2 The Supplier shall keep detailed logs and records of all activities associated with the Maintenance Event which shall be made available to AHCo upon request and as part of the reports herein.

## 14.20 Reports and Documentation

### 14.20.1 Periodic progress reports

14.20.1.1 The Supplier shall provide AHCo with periodic progress reports, which will serve as the main written communication medium through which the Supplier's observations and recommendations concerning short-term/long-term problems or improvements, shall be provided to AHCo. The reports shall be in Hebrew or English language.

14.20.1.2 There shall be three types of periodic progress reports: Monthly, Quarterly, and Annual, which shall be separate identifiable documents, such that in any given period of a year, one Annual, 4 Quarterly, and 12 Monthly reports will be forwarded to AHCo. Details of the periodical reports are detailed in Section 14.22 of this chapter.

14.20.1.3 The reports shall be submitted to AHCo no later than 7 to 11 Business Days of the completion of the reporting period (Monthly-7, Quarterly-9, Yearly-11).

14.20.1.4 All reports shall be clear and legible and submitted in hard copy or as a computer soft copy file including drawings and diagrams. The Supplier shall keep a copy of every report for backup.

14.20.1.5 All the reports shall include the following general topics as well as other requirements detailed in the following sections:

14.20.1.5.1 Summary of events & cases (faults, defects or any other anomaly), both under and beyond the control of the MUTC.

14.20.1.5.2 Summaries of calls, routine, and planned maintenance.

14.20.1.5.3 Analysis of response times, RCA time, time to repair, Work-Around response time, system modules availability, interface availability, and overall system availability – including a comparison analysis to the Service Level Requirements in this document, and a calculation of any liquidated damages incurred because of noncompliance.

14.20.1.5.4 Comments on the activities or results of work not directly associated with standard maintenance, i.e., safety surveys, refurbishment, or software modification.

14.20.1.6 Each report shall have a common format including the front cover and first inside page, which will be approved in advance by AHCo.

14.20.1.7 All three types of reports shall cover similar topics and the difference between them regarding maintenance information will be with respect to timescales, completion dates, frequency of routine maintenance, and statistical significance. A guide to the topics of each type of report will be detailed in the following sections.

### 14.20.2 Faults investigation report

14.20.2.1 For Severity 1 and Severity 2 system faults affecting the MUTC, the Supplier shall prepare and submit a fault investigation report in accordance with an AHCo-defined template, which shall be provided to the Supplier till the CDR.

14.20.2.2 The report shall document the investigation performed by the Supplier and shall include, at minimum, a description of the incident, affected services and system components, root cause analysis, contributing factors, corrective actions taken, and recommended preventive measures.

14.20.2.3 The report shall be delivered to AHCo within two (2) weeks following the occurrence of the fault, unless otherwise agreed as part of the support and operations procedures.

### 14.20.3 The MUTC Manual updates

14.20.3.1 The Supplier will maintain and update the **MUTC User Manual** (as defined in section 11.12.2.12.2 above), during the Warranty and Maintenance Periods.

14.20.3.2 The MUTC User Manual will be updated, from time to time, in a way that can at any time all the documents required for the maintenance and operation of the MUTC.

14.20.3.3 The MUTC User Manual will be updated at least in the following cases:

14.20.3.3.1 In any case of replacement or update of a component in the MUTC.

14.20.3.3.2 In case of an additional application or Version deployment.

14.20.3.3.3 In case of changes in processes workflows within the MUTC.

14.20.3.4 In case of an update in the MUTC User Manual, it is the Supplier's responsibility to update the training curriculums of the various employee groups due to upgrades.

14.20.3.5 The Supplier will submit to AHCo the MUTC User Manual in hard copies and digital media, or by any other media approved by AHCo.

## 14.21 Procedure upon termination of the Period of Engagement

Upon termination of the Period of Engagement, the Supplier will deliver the following documentation and services to AHCo:

### 14.21.1 Software licensing

Submitting a detailed list of all required software licensing models and rights of use in accordance with the Agreement's requirements, for all the MUTC components, COTS and cloud infrastructure provided by the Supplier to ensure continued operation of the MUTC.

### 14.21.2 Future Maintenance plan

The Supplier will prepare an up-to-date Future Maintenance plan, which includes detailed instructions for all the Maintenance Services activities (hereinafter: "**Future Maintenance Services Plan**"), that are required to be performed.

14.21.2.1 The Future Maintenance Services Plan will include, among other things, all the tasks, operation plans, logistics plans and work plans required for the provision of an operational MUTC going forward, including:

14.21.2.1.1 Status and monitoring of all types of licensing in all the sub-systems, expected renewal dates, dates and subjects of expected audits and surveys.

14.21.2.1.2 Management and monitoring status of all the types of agreements with sub-suppliers, and service providers.

14.21.2.1.3 Lists of all technical Staff's roles and expertise, required to execute the Future Maintenance Services Plan.

14.21.2.1.4 Future Preventive Maintenance actions and suggested schedule.

14.21.2.1.5 Actions required for creating functional continuity in cases of shutdown of critical defaults.

14.21.2.1.6 Scheduled updates and upgrading of components in the MUTC if such are required. Refer mainly to components and tools in EOS/EOL status.

### 14.21.3 Cloud and On-Prem IT environment

Submitting a detailed list of all required On-Prem and cloud IT maintenance procedures that will ensure an operational MUTC and its compliance with the best industry practices.

14.21.3.1 The Cloud and On-Prem IT environment maintenance procedures will include, among other things, all the tasks, operation plans, logistics plans and work plans required for the provisioning of an operational MUTC:

14.21.3.1.1 Monitoring cloud and On-Prem resource usage.

14.21.3.1.2 Reviewing cloud and On-Prem infrastructure and tools costs.

14.21.3.1.3 Identifying and addressing security risks.

14.21.3.1.4 Keeping cloud and On-Prem infrastructure and tools up to date.

### 14.21.4 Backup and restore

Detailed status of MUTC backups and the restore procedures.

### 14.21.5 Functional Continuity and Recovery from Extreme Situations

submitting an up-to-date functional continuity and recovery from extreme situations plan and procedures.

### 14.21.6 MUTC users list, roles and permissions

Submitting an up-to-date list of all MUTC users, roles, and permissions.

#### 14.21.7 MUTC component's status, code and documentation

Submitting an up-to-date list of all MUTC components, status, code location and configuration management, full software tree of the last approved operational version, and procedures for producing MUTC operational version together with all up-to-date MUTC documentation.

### 14.22 Periodical reports

#### 14.22.1 Monthly Reports

- 14.22.1.1 The general aim of the monthly reports shall be to document in detail the day-to-day activities of the Technical Staff during the previous month. Aspects such as maintenance staff changes, additional maintenance responsibilities, etc. shall be briefly recorded to reflect that month's events and will be detailed more fully in the quarterly and annual reports.
- 14.22.1.2 The monthly reports shall be divided into sections.
- 14.22.1.3 Introduction and General Comments - This section will include general comments relevant to all topics of this maintenance report particularly those aspects that are difficult to quantify in tabular form.
- 14.22.1.4 Corrective Maintenance – Corrective maintenance includes response to Maintenance Event callouts. Maintenance Events callouts and attendances will be summarized in the form of a list indicating the following information:
  - 14.22.1.5 Time and date of when the Maintenance Event occurred, followed by when the Supplier was notified.
  - 14.22.1.6 Fault\defect description, symptoms and influence on the MUTC operational capabilities and performance.
  - 14.22.1.7 Fault\defect Level of Severity (1-4) estimated by the AHCo system engineer.
  - 14.22.1.8 Identification and description of the faulty and/or defective component\module or interface if identified.
  - 14.22.1.9 The action was taken by the AHCo maintenance team and by the Supplier's maintenance staff.
  - 14.22.1.10 Time and date when the Maintenance Event was cleared from the system.
  - 14.22.1.11 Preventive and Adaptive Maintenance – Preventive and adaptive maintenance are usually pre-planned and shall be outlined in the report providing the following information:
    - 14.22.1.12 An annual list of all planned maintenance routines.
    - 14.22.1.13 List of maintenance routines completed during the last monthly period.
    - 14.22.1.14 List of maintenance routines to be completed in the next monthly period indicating the type of maintenance and the influence of the system in terms of performance, affected system components and system/components downtime (if required, must be approved in advance by AHCo).
    - 14.22.1.15 Maintenance Activities Reports - The Supplier shall provide a detailed report regarding each maintenance activity carried out which shall include at minimum the following information:
      - 14.22.1.16 Time and date of the activity.
      - 14.22.1.17 Duration of the activity.
      - 14.22.1.18 Detailed description of the Maintenance Event.
      - 14.22.1.19 Detailed description regarding the Work-Around, resolution activities, repair, and replacement activities.
      - 14.22.1.20 Response Time and Correction Times.
      - 14.22.1.21 The required effort to perform the activity.
      - 14.22.1.22 Risk and mitigation analysis compared to the activity results

14.22.1.23 All approvals provided by AHCo including date, name, and title of AHCo personnel who approved.

#### 14.22.2 Quarterly Reports

The main purpose of these reports shall be to provide activities summaries and aggregations of the last quarter in order to analyze and showcase support and Maintenance Services trends and the overall MUTC stability performances for the previous quarter.

#### 14.22.3 Annual Reports

14.22.3.1 The purpose of this report is to combine all of the summaries, statistical records, and any non-periodic information of the past year, to present an objective appraisal on an annual basis, of the Maintenance Services level of service provided by the Supplier, trends and the overall MUTC stability performances for the past year.

14.22.3.2 This report shall also identify and recommend improvements and changes to be made, for enhancing the MUTC capabilities and to prevent obsolescence of software and hardware components.

14.22.3.3 The format of the Annual reports shall be divided into the following sections:

14.22.3.4 Introduction and General Comments - This section will include general comments relevant to all topics of this reporting period.

14.22.3.5 Maintenance Statistics - Graphical or diagrammatical representation of various aspects of corrective maintenance over the past year, drawn from the monthly and quarterly reports. This section outlines the requirements for this statistical approach and shall include the following information:

14.22.3.5.1 Total quantity and type of main system faults and defects generated and cleared over the year. These Maintenance Events statistics may be presented graphically as quantity against time in monthly steps showing start and end dates.

14.22.3.5.2 Average and total number of faults and defects per type of component/module/interface over the whole year.

14.22.3.5.3 Average and total number of faults and defects clearance methods (resets, changing setups, memory clearance, software patch, etc.).

14.22.3.6 Annual Preventive and Adaptive Maintenance - This section shall include aspects of preventive and adaptive maintenance that were performed during the year and that are required throughout the coming year with emphasis on those with an influence of one or more years.

14.22.3.7 Other Maintenance Activities - This section shall include maintenance activities throughout the year that cannot be defined as a Maintenance Event or planned maintenance. This information will relate generally to activities such as surveys, refurbishment, and modification programs. The following details will be required:

14.22.3.7.1 Nature of the activity

14.22.3.7.2 Time, date and duration

14.22.3.7.3 The required effort to perform the activity.

14.22.3.7.4 Risk and mitigation analysis

14.22.3.8 Long-Term Analysis and Recommendations - The purpose of this section is for the Supplier to provide specific improvements and general recommendations that can be implemented in the long term (i.e., implementation within one to two years).

### **14.23 Spare Parts Inventory**

14.23.1 The Supplier undertakes to maintain, at his own expense, a warehouse within an area that is within a driving distance on roads not exceeding fifty (50) km from the geographical location of one of MANTAM throughout the duration of the contract.

14.23.2 The Supplier shall maintain the spare-parts inventory in a manner sufficient to comply with all response and restoration time requirements set out in this Agreement. The inventory requirements in this Section define minimum stock obligations and shall not limit the Supplier's responsibility to hold any additional spare parts, replacement units, tools, or equipment required to meet the applicable SLA obligations

14.23.3 Throughout the entire term of the Agreement, the Supplier shall maintain in its warehouse in Israel a minimum inventory of at least ten percent (10%) of the installed products and at least ten (10) units, plus a safety stock of two (2) units, or such higher quantity as may be required to comply with the applicable

SLA obligations.

- 14.23.4 Spare parts that are not classified as Critical Spare Parts shall be available for supply for the purpose of replacing defective products and/or adding products within three (3) working days. Critical Spare Parts shall be available in accordance with the SLA requirements applicable to the affected incident severity level.
- 14.23.5 The remaining required products, beyond the inventory available in Israel, shall be supplied within 25 working days from the AHCo's notification and/or its representative regarding the need to perform the replacement.
- 14.23.6 It is clarified that the requirement to supply a specific quantity of products does not exempt the Supplier from its responsibility to maintain the existing inventory levels in Israel as required above.
- 14.23.7 The inventory of spare parts will be inspected by a representative of AHCo (for example by the Supervisor) whenever they deem necessary.
- 14.23.8 The replenishment of parts and equipment shall be carried out regularly by the Supplier as they are used for maintenance purposes. Critical Spare Parts shall be replenished without undue delay and in any event in a manner that preserves compliance with the applicable SLA obligations.
- 14.23.9 A report specifying the list of equipment, spare parts, and inventory will be submitted to AHCo from time to time and as requested.
- 14.23.10 The Supplier must obtain the Supervisor's approval for all items and spare parts held in inventory. The Supervisor may request testing of materials and equipment in the Supplier's laboratories and/or approved external laboratories to verify compliance and quality of the equipment and materials, at the Supplier's expense.
- 14.23.11 This equipment and these parts are the property of the Supplier, but the obligation to keep them in the warehouse as defined above will be subject to and under the supervision of AHCo.
- 14.23.12 The Supplier shall replenish the above-mentioned inventory every six months and/or immediately in case parts or items are used in a manner that reduces the specific inventory for that particular item below the minimum approved stock level. For Critical Spare Parts, the minimum approved stock level shall be the level required to maintain SLA compliance.
- 14.23.13 Parts replaced as part of maintenance work and/or damage repair as specified in Section 14, except for detectors, computational devices, and network devices replaced according to the provisions of this section, will remain the property of the Supplier, who must dispose of them to their warehouses or to a legally authorized waste site.
- 14.23.14 Detectors, computational devices, and network devices that will be replaced or dismantled as part of the maintenance service works, as detailed in section 14, shall remain the property of AHCo and shall be transferred by the Supplier to the AHCo's warehouses or to any other location designated by AHCo, at the Supplier's expense.